



**NAHRAB GOSTAR ESHTEHARD**

Manufacture of Industrial Valves & relevant equipment

# Swing Check Valves



[www.nahrab.net](http://www.nahrab.net) - [info@nahrab.net](mailto:info@nahrab.net)



## Swing Check valve

**Flanged Standard:** EN 1092-2 / ISO  
7005-02 AS-2190D/ BS10

**Size (DN):** 50-300 mm

**Pressure (PN):** 10-16 bar

**Coating** Electrostatic Epoxy powder, RAL 5005, 250µm

### Product Application:

- Prevention of reverse flow on system shutdown.
- Prevention of flow under gravity).
- Relief of vacuum conditions.
- Protection of any item of equipment that can be affected by reverse flow.

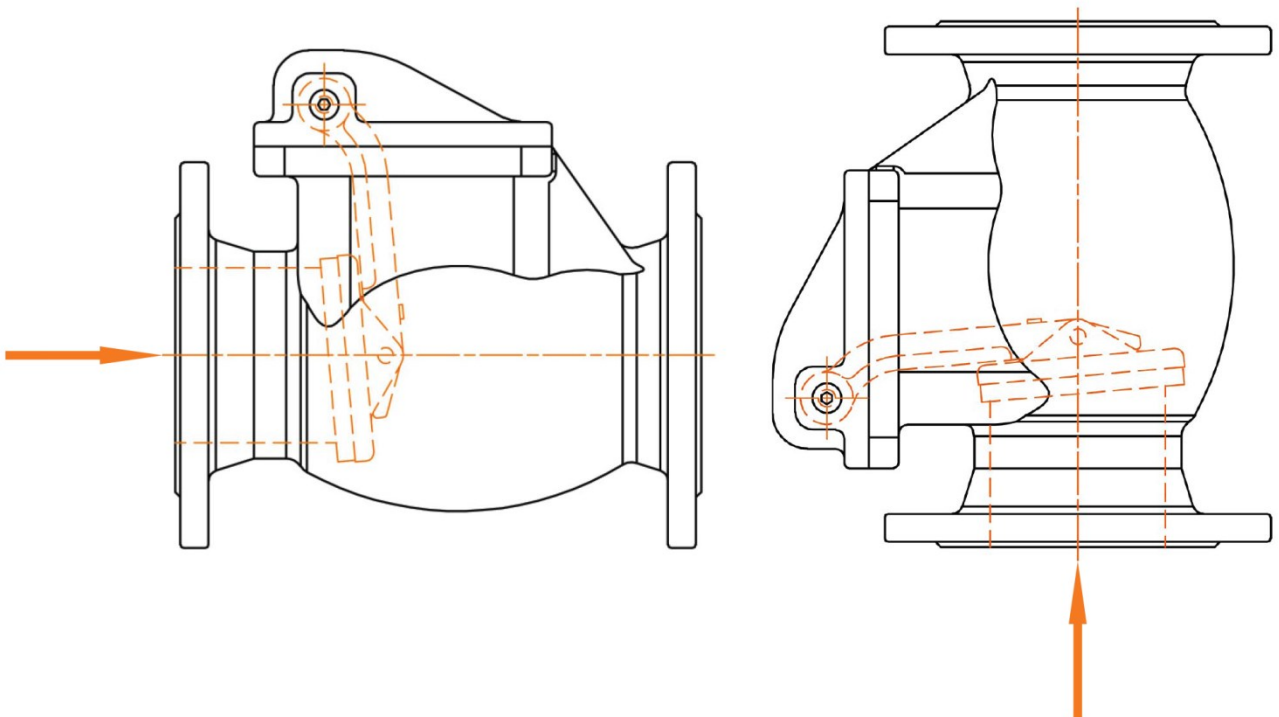

## Material List

Part	Description	Material
1	Body	EN-GJS-300-7
2	Sealing ring	1.4301
3	Bonnet	EN-GJS-300-7
4	Seal	NBR
5	Lever	EN-GJS-300-7
6	Lever pin	1.4021
7	Cap	Brass
8	Disk	EN-GJS-300-7
9	O-Ring	NBR
10	Disc Pin	1.4021
11	Anti Shock Rubber	NBR
12	Bolt & Washer	A2

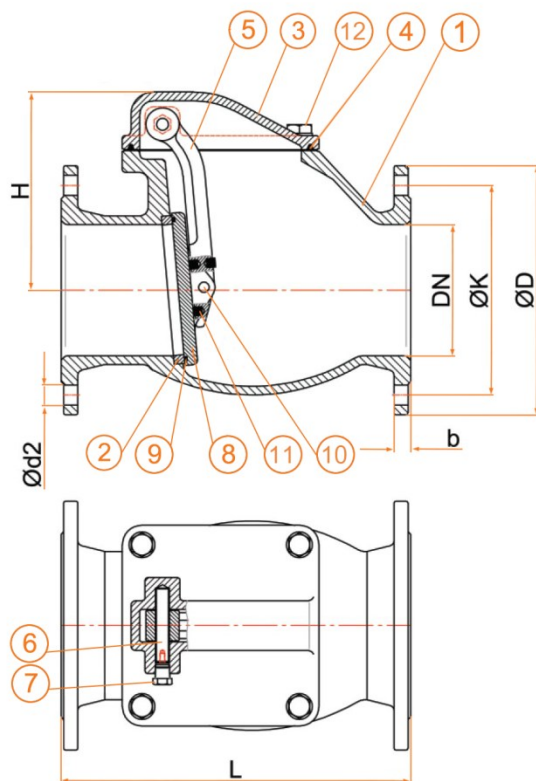

DN mm	PN bar	L * mm	ØD mm	ØK mm	b mm	Ød2 mm	n Mm	h mm	Weight
50	10 / 16	200	165	125	19	19	4	123	12
65	10 / 16	240	185	145	19	19	4	139	16
80	10 / 16	260	200	160	19	19	8	154	21
100	10 / 16	300	220	180	19	19	8	177	29
125	10 / 16	350	250	210	19	19	8	202	38
150	10 / 16	400	285	240	23	23	8	227	50
200	10	230	340	295	23	23	8	280	93
	16						12		
250	10	250	395	350	23	23	12	350	135
	16		405	355	28	28			
300	10	270	445	400	23	23	12	430	175
	16		455	410	28	28			

\* DIN EN 558-1 48 (DIN 3202 F6)



**NAHRAB GOSTAR ESHTEHARD**

Manufacture of Industrial Valves & Relevant Equipment

---

**Central Office**

No.408 , Borj e Sefid (Sefid Tower) ,  
Pasdaran ST , Tehran - Iran  
Telephone : +98 (21) 27640 -- Fax: +98 (21) 22569144

**Factory**

4th Takestan , West Ghazali , Aboreyhan BLVD ,  
Eshtehard Industrial City  
Alborz - Iran  
Telephone : +98 (26) 37773930-33 Fax: +98 (26) 37773932

[www.nahrab.net](http://www.nahrab.net)

[Info@nahrab.net](mailto:Info@nahrab.net)