

Axial Piston Fixed Motor A2FM

RE 91001/06.2012

1/46

Replaces: 09.07

Data sheet

Series 6	
Size	Nominal pressure/Maximum pressure
5	315/350 bar
10 to 200	400/450 bar
250 to 1000	350/400 bar
Open and closed circuits	



Contents

Ordering code for standard program	2
Technical data	4
Dimensions	11
Flushing and boost pressure valve	34
Pressure-relief valve	36
Counterbalance valve BVD and BVE	38
Speed sensors	42
Installation instructions	44
General instructions	46

Features

- Fixed motor with axial tapered piston rotary group of bent-axis design, for hydrostatic drives in open and closed circuits
- For use in mobile and stationary applications
- The output speed is dependent on the flow of the pump and the displacement of the motor.
- The output torque increases with the pressure differential between the high-pressure and the low-pressure side.
- Finely graduated sizes permit far-reaching adaptation to the drive case
- High power density
- Small dimensions
- High total efficiency
- Good starting characteristics
- Economical design
- One-piece tapered piston with piston rings for sealing

Ordering code for standard program

	A2F		M		/	6		W	-	V						
01	02	03	04	05		06	07	08		09	10	11	12	13	14	15

Port plates for service lines ²⁾		5	10-16	23	28, 32	45	56,63	80,90	107-125	160-180	200	250	355-500	1000		
12	SAE flange ports A and B at rear	01	0	-	-	●	●	●	●	●	●	●	●	●	●	010
			7	-	-	-	-	-	-	-	-	-	-	●	-	017
	SAE flange ports A and B at side, opposite	02	0	-	-	●	●	●	●	●	●	-	●	-	-	020
			7	-	-	-	●	▲	▲	●	●	-	●	-	-	027
			9	-	-	-	-	●	●	-	-	-	-	-	-	029
	Threaded ports A and B at side, opposite	03	0	●	●	●	●	-	-	-	-	-	-	-	-	030
	Threaded ports A and B at side and rear ³⁾	04	0	-	●	●	●	●	-	-	-	-	○	-	-	040
	SAE flange ports A and B at bottom (same side)	10	0	-	-	-	●	●	●	●	●	-	-	○	-	100
	Port plate with 1-level pressure- relief valves for mounting a counterbalance valve ⁵⁾	BVD 17	1	-	-	-	-	-	-	●	-					171 178
		BVE 18	8	-	-	-	●	●	●	●	●	-	-	-	-	181 188
			18	-	-	-	-	-	-	●	●	-	- ⁴⁾	-	-	
	Port plate with pressure-relief valves	19	1	-	-	-	●	●	●	●	●	-	-	-	-	191
		2	-	-	-	●	●	●	●	●	-	-	-	-	192	

Valves (see pages 34 to 41)

Without valve	0
Pressure-relief valve (without pressure boost facility)	1
Pressure-relief valve (with pressure boost facility)	2
Flushing and boost pressure valve, mounted	7
Counterbalance valve BVD/BVE mounted ⁵⁾⁶⁾	8
Flushing and boost pressure valve, integrated	9

Speed sensors (see pages 42 and 43)		5 to 16	23 to 180	200	250 to 500	710 to 1000 ⁴⁾	
13	Without speed sensor (without code)	●	●	●	●	●	
	Prepared for HDD speed sensor	-	▲	▲	●	-	F
	HDD speed sensor mounted ⁷⁾	-	▲	▲	●	-	H
	Prepared for DSA speed sensor	-	○	○	○	-	U
	DSA speed sensor mounted ⁷⁾	-	○	○	○	-	V

Special version

14	Standard version (without code)	
	Special version for slew drives (standard with port plate 19)	J

Standard / special version

15	Standard version (without code)	
	Standard version with installation variants, e. g. T ports against standard open or closed	-Y
	Special version	-S

● = Available ○ = On request - = Not available ▲ = Not for new projects ■ = Preferred program

- 2) Fastening thread or threaded ports, metric
- 3) Threaded ports at the sides (sizes 10 to 63) plugged with threaded plugs
- 4) Please contact us.
- 5) Note the restrictions on page 39.
- 6) Specify ordering code of counterbalance valve according to data sheet (BVD – RE 95522, BVE – RE 95525) separately.
- 7) Specify ordering code of sensor according to data sheet (DSA – RE 95133, HDD – RE 95135) separately and observe the requirements on the electronics

Technical data

Hydraulic fluid

Before starting project planning, please refer to our data sheets RE 90220 (mineral oil), RE 90221 (environmentally acceptable hydraulic fluids), RE 90222 (HFD hydraulic fluids) and RE 90223 (HFA, HFB, HFC hydraulic fluids) for detailed information regarding the choice of hydraulic fluid and application conditions.

The fixed motor A2FM is not suitable for operation with HFA hydraulic fluid. If HFB, HFC or HFD or environmentally acceptable hydraulic fluids are used, the limitations regarding technical data or other seals must be observed.

Selection diagram

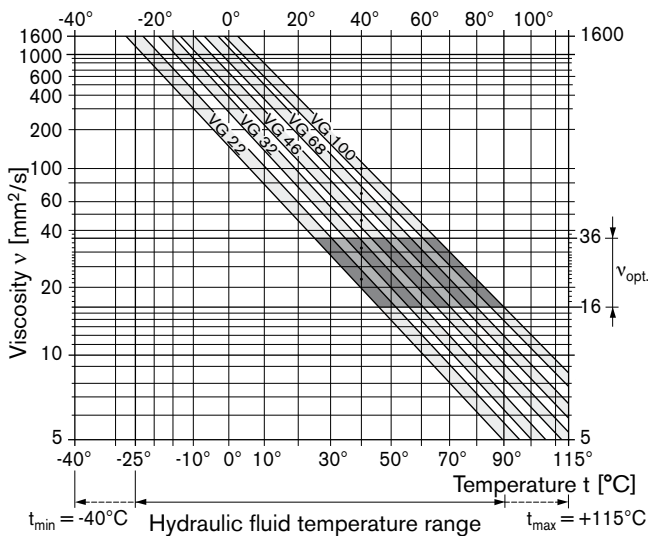

Details regarding the choice of hydraulic fluid

The correct choice of hydraulic fluid requires knowledge of the operating temperature in relation to the ambient temperature: in a closed circuit, the circuit temperature, in an open circuit, the reservoir temperature.

The hydraulic fluid should be chosen so that the operating viscosity in the operating temperature range is within the optimum range (ν_{opt} see shaded area of the selection diagram). We recommend that the higher viscosity class be selected in each case.

Example: At an ambient temperature of X °C, an operating temperature of 60 °C is set in the circuit. In the optimum operating viscosity range (ν_{opt} , shaded area), this corresponds to the viscosity classes VG 46 or VG 68; to be selected: VG 68.

Note

The case drain temperature, which is affected by pressure and speed, can be higher than the circuit temperature or reservoir temperature. At no point of the component may the temperature be higher than 115 °C. The temperature difference specified below is to be taken into account when determining the viscosity in the bearing.

If the above conditions cannot be maintained due to extreme operating parameters, we recommend flushing the case at port U (sizes 250 to 1000) or using a flushing and boost pressure valve (see pages 34).

Viscosity and temperature of hydraulic fluid

	Viscosity [mm ² /s]	Temperature	Comment
Transport and storage at ambient temperature		$T_{min} \geq -50^\circ\text{C}$ $T_{opt} = +5^\circ\text{C}$ to $+20^\circ\text{C}$	factory preservation: up to 12 months with standard, up to 24 months with long-term
(Cold) start-up ¹⁾	$\nu_{max} = 1600$	$T_{St} \geq -40^\circ\text{C}$	$t \leq 3$ min, without load ($p \leq 50$ bar), $n \leq 1000$ rpm (for sizes 5 to 200), $n \leq 0.25 \cdot n_{nom}$ (for sizes 250 to 1000)
Permissible temperature difference		$\Delta T \leq 25$ K	between axial piston unit and hydraulic fluid
Warm-up phase	$\nu < 1600$ to 400	$T = -40^\circ\text{C}$ to -25°C	at $p \leq 0.7 \cdot p_{nom}$, $n \leq 0.5 \cdot n_{nom}$ and $t \leq 15$ min
Operating phase			
Temperature difference		$\Delta T = \text{approx. } 12$ K	between hydraulic fluid in the bearing and at port T.
Maximum temperature		115 °C	in the bearing
		103 °C	measured at port T
Continuous operation	$\nu = 400$ to 10 $\nu_{opt} = 36$ to 16	$T = -25^\circ\text{C}$ to $+90^\circ\text{C}$	measured at port T, no restriction within the permissible data
Short-term operation ²⁾	$\nu_{min} \geq 7$	$T_{max} = +103^\circ\text{C}$	measured at port T, $t < 3$ min, $p < 0.3 \cdot p_{nom}$
FKM shaft seal ¹⁾		$T \leq +115^\circ\text{C}$	see page 5

1) At temperatures below -25°C , an NBR shaft seal is required (permissible temperature range: -40°C to $+90^\circ\text{C}$).

2) Sizes 250 to 1000, please contact us.

Technical data

Filtration of the hydraulic fluid

Finer filtration improves the cleanliness level of the hydraulic fluid, which increases the service life of the axial piston unit.

To ensure the functional reliability of the axial piston unit, a gravimetric analysis of the hydraulic fluid is necessary to determine the amount of solid contaminant and to determine the cleanliness level according to ISO 4406. A cleanliness level of at least 20/18/15 is to be maintained.

At very high hydraulic fluid temperatures (90 °C to maximum 115 °C), a cleanliness level of at least 19/17/14 according to ISO 4406 is necessary.

If the above classes cannot be achieved, please contact us.

Shaft seal

Permissible pressure loading

The service life of the shaft seal is influenced by the speed of the axial piston unit and the case drain pressure (case pressure). The mean differential pressure of 2 bar between the case and the ambient pressure may not be enduringly exceeded at normal operating temperature. For a higher differential pressure at reduced speed, see diagram. Momentary pressure spikes ($t < 0.1$ s) of up to 10 bar are permitted. The service life of the shaft seal decreases with an increase in the frequency of pressure spikes.

The case pressure must be equal to or higher than the ambient pressure.

Sizes 10 to 200

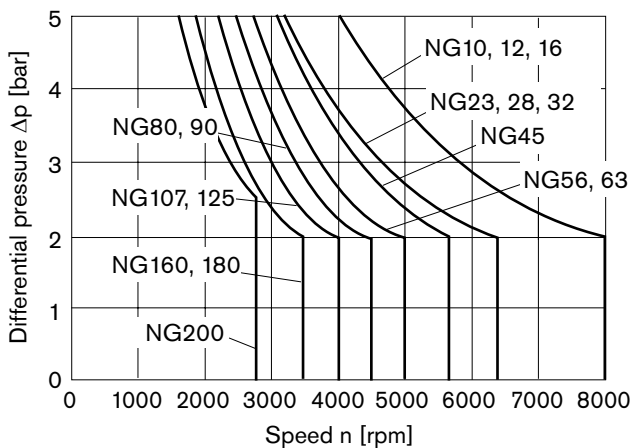

Sizes 250 to 1000

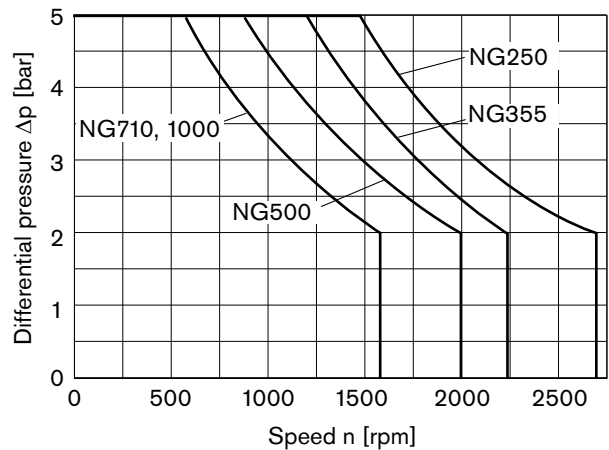

The values are valid for an ambient pressure $p_{abs} = 1$ bar.

Temperature range

The FKM shaft seal may be used for case drain temperatures from -25 °C to +115 °C.

Note

For application cases below -25 °C, an NBR shaft seal is required (permissible temperature range: -40 °C to +90 °C). State NBR shaft seal in plain text when ordering. Please contact us.

Direction of flow

Direction of rotation, viewed on drive shaft

clockwise

counter-clockwise

A to B

B to A

Speed range

No limit to minimum speed n_{min} . If uniformity of motion is required, speed n_{min} must not be less than 50 rpm. See table of values on page 7 for maximum speed.

Long-life bearing

Sizes 250 to 1000

For long service life and use with HF hydraulic fluids. Identical external dimensions as motor with standard bearings. Subsequent conversion to long-life bearings is possible. Bearing and case flushing via port U is recommended.

Flushing flow (recommended)

NG	250	355	500	710	1000
$q_{v \text{ flush}}$ (L/min)	10	16	16	16	16

Technical data

Operating pressure range

(operating with mineral oil)

Pressure at service line port A or B

Size 5

Nominal pressure p_{nom} _____ 315 bar absolute

Maximum pressure p_{max} _____ 350 bar absolute

Single operating period _____ 10 s

Total operating period _____ 300 h

Summation pressure (pressure A + pressure B) p_{Su} 630 bar

Sizes 10 to 200

Nominal pressure p_{nom} _____ 400 bar absolute

Maximum pressure p_{max} _____ 450 bar absolute

Single operating period _____ 10 s

Total operating period _____ 300 h

Summation pressure (pressure A + pressure B) p_{Su} _ 700 bar

Sizes 250 to 1000

Nominal pressure p_{nom} _____ 350 bar absolute

Maximum pressure p_{max} _____ 400 bar absolute

Single operating period _____ 10 s

Total operating period _____ 300 h

Summation pressure (pressure A + pressure B) p_{Su} _ 700 bar

Minimum pressure (high-pressure side) ___ 25 bar absolute

Rate of pressure change $R_{A\ max}$

with integrated pressure-relief valve _____ 9000 bar/s

without pressure-relief valve _____ 16000 bar/s

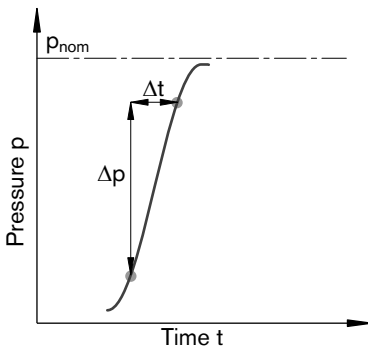

Note

Values for other hydraulic fluids, please contact us.

Minimum pressure – pump mode (inlet)

To prevent damage to the axial piston motor in pump operating mode (change of high-pressure side with unchanged direction of rotation, e. g. when braking), a minimum pressure must be guaranteed at the service line port (inlet). The minimum pressure depends on the speed of the axial piston unit (see characteristic curve below).

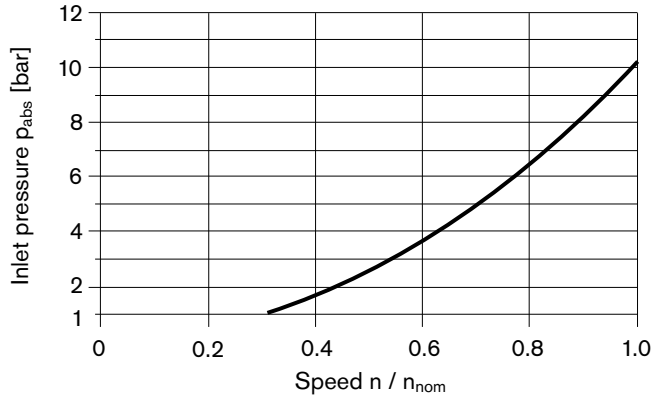

This diagram is valid only for the optimum viscosity range from $v_{opt} = 36$ to $16\ mm^2/s$.

Please contact us if these conditions cannot be satisfied.

Definition

Nominal pressure p_{nom}

The nominal pressure corresponds to the maximum design pressure.

Maximum pressure p_{max}

The maximum pressure corresponds to the maximum operating pressure within the single operating period. The sum of the single operating periods must not exceed the total operating period.

Minimum pressure (high-pressure side)

Minimum pressure at the high-pressure side (A or B) which is required in order to prevent damage to the axial piston unit.

Summation pressure p_{Su}

The summation pressure is the sum of the pressures at both service line ports (A and B).

Rate of pressure change R_A

Maximum permissible rate of pressure rise and reduction during a pressure change over the entire pressure range.

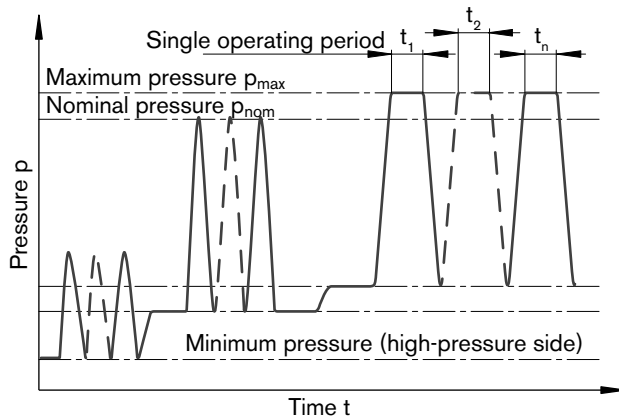

Total operating period = $t_1 + t_2 + \dots + t_n$

Technical data

Table of values (theoretical values, without efficiency and tolerances; values rounded)

Size	NG		5	10	12	16	23	28	32	45	56	63	80
Displacement geometric, per revolution	V_g	cm ³	4.93	10.3	12	16	22.9	28.1	32	45.6	56.1	63	80.4
Speed maximum ¹⁾	n_{nom}	rpm	10000	8000	8000	8000	6300	6300	6300	5600	5000	5000	4500
	$n_{max}^{2)}$	rpm	11000	8800	8800	8800	6900	6900	6900	6200	5500	5500	5000
Input flow ³⁾ at n_{nom} and V_g	q_v	L/min	49	82	96	128	144	177	202	255	281	315	362
Torque ⁴⁾ at V_g and $\Delta p = 350$ bar	T	Nm	24.7 ⁵⁾	57	67	89	128	157	178	254	313	351	448
	T	Nm	–	66	76	102	146	179	204	290	357	401	512
Rotary stiffness	c	kNm/rad	0.63	0.92	1.25	1.59	2.56	2.93	3.12	4.18	5.94	6.25	8.73
Moment of inertia for rotary group	J_{GR}	kgm ²	0.00006	0.0004	0.0004	0.0004	0.0012	0.0012	0.0012	0.0024	0.0042	0.0042	0.0072
Maximum angular acceleration	α	rad/s ²	5000	5000	5000	5000	6500	6500	6500	14600	7500	7500	6000
Case volume	V	L		0.17	0.17	0.17	0.20	0.20	0.20	0.33	0.45	0.45	0.55
Mass (approx.)	m	kg	2.5	5.4	5.4	5.4	9.5	9.5	9.5	13.5	18	18	23

Size	NG		90	107	125	160	180	200	250	355	500	710	1000
Displacement geometric, per revolution	V_g	cm ³	90	106.7	125	160.4	180	200	250	355	500	710	1000
Speed maximum ¹⁾	n_{nom}	rpm	4500	4000	4000	3600	3600	2750	2700	2240	2000	1600	1600
	$n_{max}^{2)}$	rpm	5000	4400	4400	4000	4000	3000	–	–	–	–	–
Input flow ³⁾ at n_{nom} and V_g	q_v	L/min	405	427	500	577	648	550	675	795	1000	1136	1600
Torque ⁴⁾ at V_g and $\Delta p = 350$ bar	T	Nm	501	594	696	893	1003	1114	1393	1978	2785	3955	5570
	T	Nm	573	679	796	1021	1146	1273	–	–	–	–	–
Rotary stiffness	c	kNm/rad	9.14	11.2	11.9	17.4	18.2	57.3	73.1	96.1	144	270	324
Moment of inertia for rotary group	J_{GR}	kgm ²	0.0072	0.0116	0.0116	0.0220	0.0220	0.0353	0.061	0.102	0.178	0.55	0.55
Maximum angular acceleration	α	rad/s ²	6000	4500	4500	3500	3500	11000	10000	8300	5500	4300	4500
Case volume	V	L	0.55	0.8	0.8	1.1	1.1	2.7	2.5	3.5	4.2	8	8
Mass (approx.)	m	kg	23	32	32	45	45	66	73	110	155	325	336

1) The values are valid:

- for the optimum viscosity range from $\nu_{opt} = 36$ to 16 mm²/s
- with hydraulic fluid based on mineral oils

2) Intermittent maximum speed: overspeed for unload and overhauling processes, $t < 5$ s and $\Delta p < 150$ bar

3) Restriction of input flow with counterbalance valve, see page 39

4) Torque without radial force, with radial force see page 8

5) Torque at $\Delta p = 315$ bar

Note

Operation above the maximum values or below the minimum values may result in a loss of function, a reduced service life or in the destruction of the axial piston unit. Other permissible limit values, with respect to speed variation, reduced angular acceleration as a function of the frequency and the permissible start up angular acceleration (lower than the maximum angular acceleration) can be found in data sheet RE 90261.

Technical data

Permissible radial and axial forces of the drive shafts

(splined shaft and parallel keyed shaft)

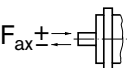
Size	NG		5	5 ³⁾	10	10	12	12	16	23	23	
Drive shaft	ø	mm	12	12	20	25	20	25	25	25	30	
Maximum radial force ¹⁾ at distance a (from shaft collar)		$F_{q \max}$	kN	1.6	1.6	3.0	3.2	3.0	3.2	3.2	5.7	5.4
		a	mm	12	12	16	16	16	16	16	16	16
with permissible torque	T_{\max}	Nm	24.7	24.7	66	66	76	76	102	146	146	
△ permissible pressure Δp	Δp_{perm}	bar	315	315	400	400	400	400	400	400	400	
Maximum axial force ²⁾		$+F_{ax \max}$	N	180	180	320	320	320	320	320	500	500
		$-F_{ax \max}$	N	0	0	0	0	0	0	0	0	0
Permissible axial force per bar operating pressure	$\pm F_{ax \text{ perm}/\text{bar}}$	N/bar	1.5	1.5	3.0	3.0	3.0	3.0	3.0	5.2	5.2	

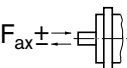
Size	NG		28	28	32	45	56	56 ⁴⁾	56	63	80	
Drive shaft	ø	mm	25	30	30	30	30	30	35	35	35	
Maximum radial force ¹⁾ at distance a (from shaft collar)		$F_{q \max}$	kN	5.7	5.4	5.4	7.6	9.5	7.8	9.1	9.1	11.6
		a	mm	16	16	16	18	18	18	18	18	20
with permissible torque	T_{\max}	Nm	179	179	204	290	357	294	357	401	512	
△ permissible pressure Δp	Δp_{perm}	bar	400	400	400	400	400	330	400	400	400	
Maximum axial force ²⁾		$+F_{ax \max}$	N	500	500	500	630	800	800	800	1000	
		$-F_{ax \max}$	N	0	0	0	0	0	0	0	0	0
Permissible axial force per bar operating pressure	$\pm F_{ax \text{ perm}/\text{bar}}$	N/bar	5.2	5.2	5.2	7.0	8.7	8.7	8.7	8.7	10.6	

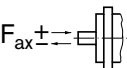
Size	NG		80 ⁴⁾	80	90	107	107	125	160	160	180	
Drive shaft	ø	mm	35	40	40	40	45	45	45	50	50	
Maximum radial force ¹⁾ at distance a (from shaft collar)		$F_{q \max}$	kN	11.1	11.4	11.4	13.6	14.1	14.1	18.1	18.3	18.3
		a	mm	20	20	20	20	20	20	25	25	25
with permissible torque	T_{\max}	Nm	488	512	573	679	679	796	1021	1021	1146	
△ permissible pressure Δp	Δp_{perm}	bar	380	400	400	400	400	400	400	400	400	
Maximum axial force ²⁾		$+F_{ax \max}$	N	1000	1000	1000	1250	1250	1250	1600	1600	1600
		$-F_{ax \max}$	N	0	0	0	0	0	0	0	0	0
Permissible axial force per bar operating pressure	$\pm F_{ax \text{ perm}/\text{bar}}$	N/bar	10.6	10.6	10.6	12.9	12.9	12.9	16.7	16.7	16.7	

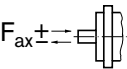
Size	NG		200	250	355	500	710	1000	
Drive shaft	ø	mm	50	50	60	70	90	90	
Maximum radial force ¹⁾ at distance a (from shaft collar)		$F_{q \max}$	kN	20.3	1.2 ⁶⁾	1.5 ⁶⁾	1.9 ⁶⁾	3.0 ⁶⁾	2.6 ⁶⁾
		a	mm	25	41	52.5	52.5	67.5	67.5
with permissible torque	T_{\max}	Nm	1273	5)	5)	5)	5)	5)	
△ permissible pressure Δp	Δp_{perm}	bar	400	5)	5)	5)	5)	5)	
Maximum axial force ²⁾		$+F_{ax \max}$	N	1600	2000	2500	3000	4400	4400
		$-F_{ax \max}$	N	0	0	0	0	0	0
Permissible axial force per bar operating pressure	$\pm F_{ax \text{ perm}/\text{bar}}$	N/bar	16.7	5)	5)	5)	5)	5)	

1) With intermittent operation

2) Maximum permissible axial force during standstill or when the axial piston unit is operating in non-pressurized condition.

3) Conical shaft with threaded pin and woodruff key (DIN 6888)

4) Restricted technical data only for splined shaft

5) Please contact us.

6) When at a standstill or when axial piston unit operating in non-pressurized conditions. Higher forces are permissible when under pressure, please contact us.

Note

Influence of the direction of the permissible axial force:

$+F_{ax \max}$ = Increase in service life of bearings

$-F_{ax \max}$ = Reduction in service life of bearings (avoid)

Technical data

Effect of radial force F_q on the service life of bearings

By selecting a suitable direction of radial force F_q , the load on the bearings, caused by the internal rotary group forces can be reduced, thus optimizing the service life of the bearings. Recommended position of mating gear is dependent on direction of rotation. Examples:

	Toothed gear drive	V-belt output
NG	φ_{opt}	φ_{opt}
5 to 180	$\pm 70^\circ$	$\pm 45^\circ$
200 to 1000	$\pm 45^\circ$	$\pm 70^\circ$

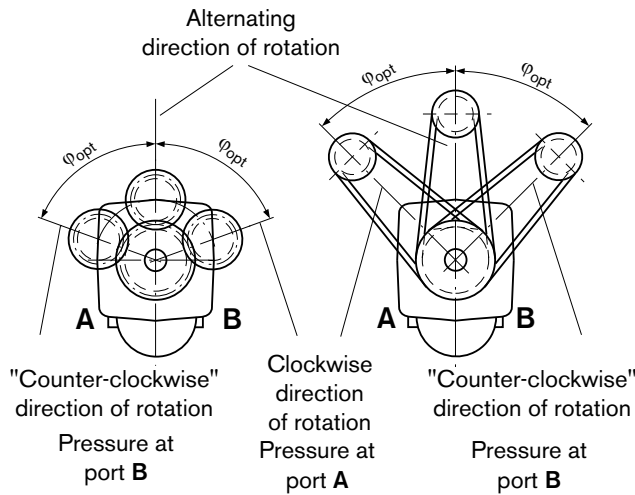

Determining the operating characteristics

Input flow $q_v = \frac{V_g \cdot n}{1000 \cdot \eta_v}$ [L/min]

Speed $n = \frac{q_v \cdot 1000 \cdot \eta_v}{V_g}$ [min⁻¹]

Torque $T = \frac{V_g \cdot \Delta p \cdot \eta_{mh}}{20 \cdot \pi}$ [Nm]

Power $P = \frac{2 \pi \cdot T \cdot n}{60000} = \frac{q_v \cdot \Delta p \cdot \eta_t}{600}$ [kW]

V_g = Displacement per revolution in cm³

Δp = Differential pressure in bar

n = Speed in rpm

η_v = Volumetric efficiency

η_{mh} = Mechanical-hydraulic efficiency

η_t = Total efficiency ($\eta_t = \eta_v \cdot \eta_{mh}$)

Dimensions size 5

Before finalizing your design, request a binding installation drawing. Dimensions in mm.

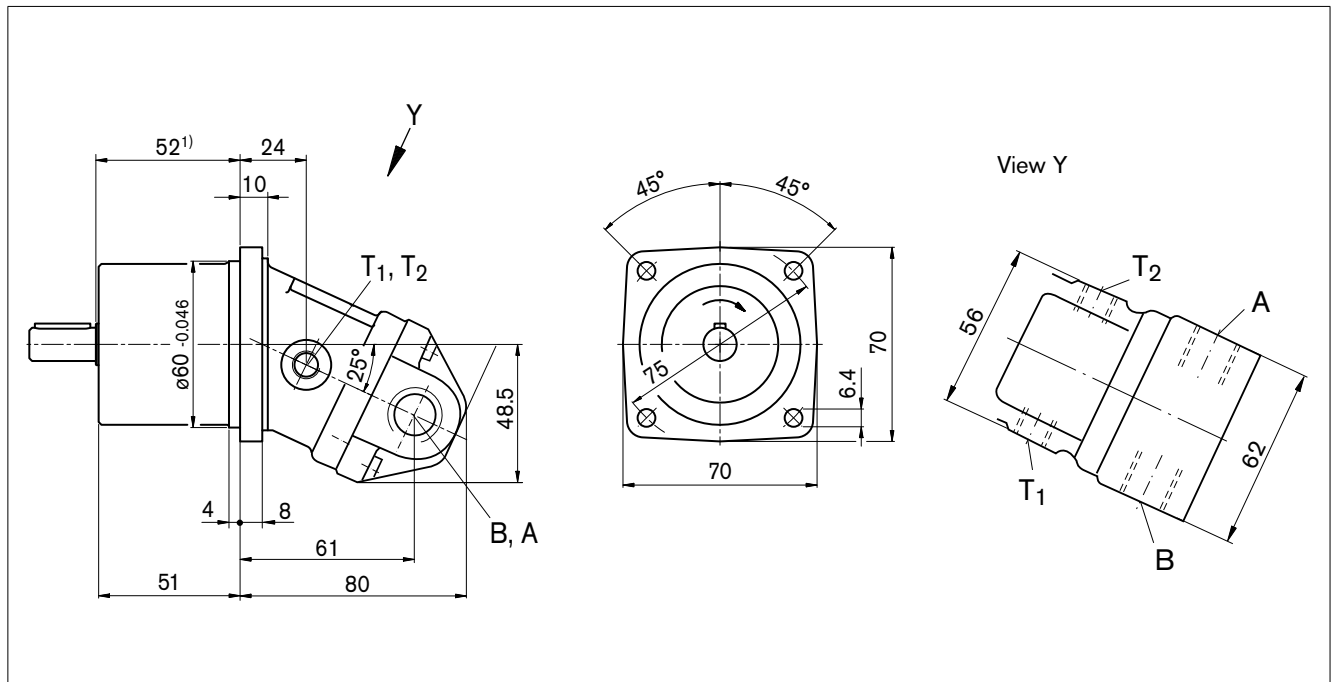

Drive shafts

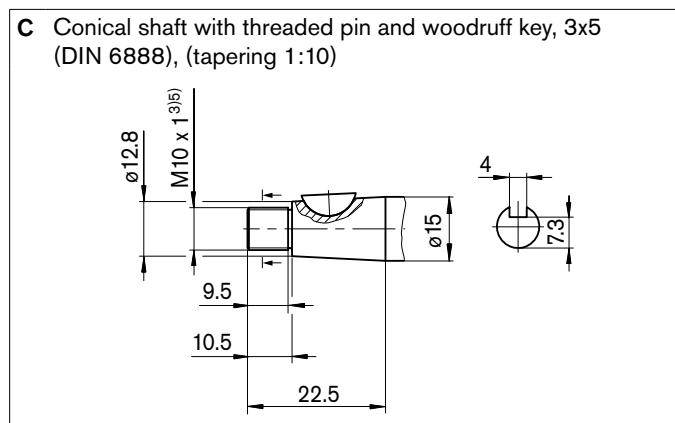
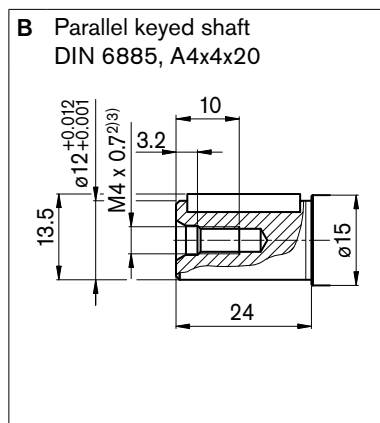

Ports

Designation	Port for	Standard ⁶⁾	Size ³⁾	Maximum pressure [bar] ⁴⁾	State ⁷⁾
A, B	Service line	DIN 3852	M18 x 1.5; 12 deep	350	O
T ₁	Drain line	DIN 3852	M10 x 1; 8 deep	3	O
T ₂	Drain line	DIN 3852	M10 x 1; 8 deep	3	O

1) To shaft collar

2) Center bore according to DIN 332 (thread according to DIN 13)

3) Observe the general instructions on page 46 for the maximum tightening torques.

4) Momentary pressure spikes may occur depending on the application. Keep this in mind when selecting measuring devices and fittings.

5) Thread according to DIN 3852, maximum tightening torque: 30 Nm

6) The spot face can be deeper than specified in the appropriate standard.

7) O = Must be connected (plugged on delivery)

Dimensions sizes 10, 12, 16

Before finalizing your design, request a binding installation drawing. Dimensions in mm.

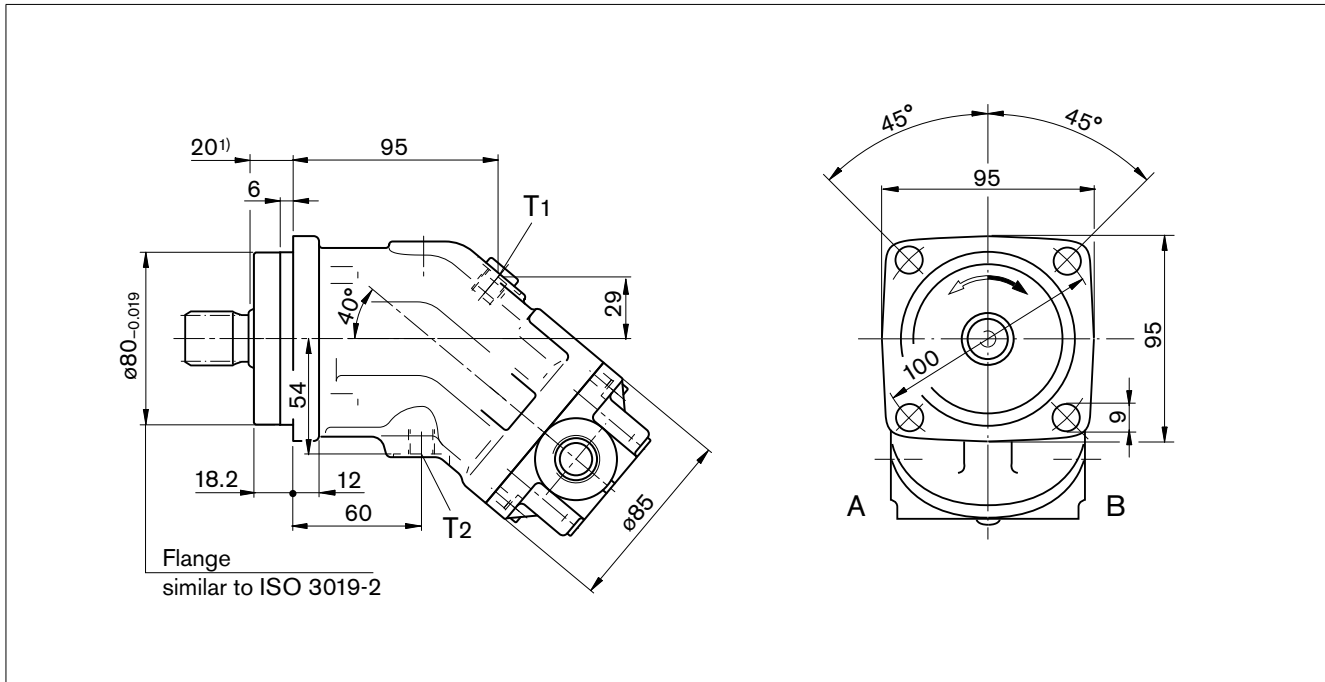

Drive shafts

Sizes 10, 12, 16

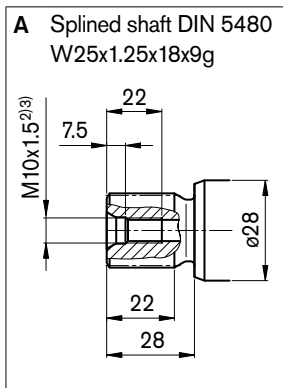

Sizes 10, 12

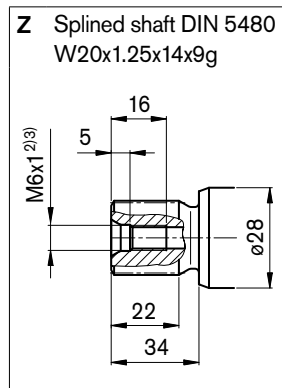

Sizes 10, 12, 16

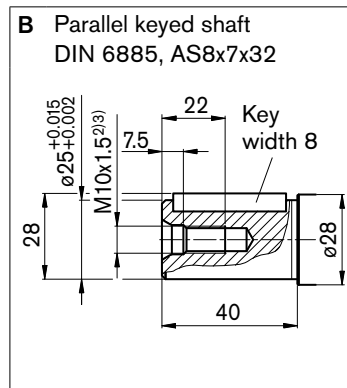

Sizes 10, 12

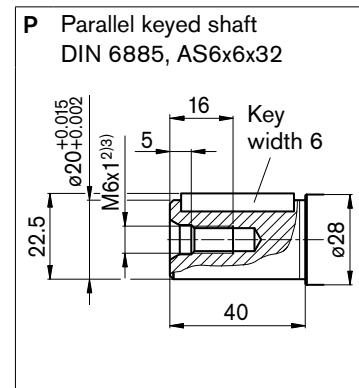

Ports

Designation	Port for	Standard	Size ³⁾	Maximum pressure [bar] ⁴⁾	State ⁷⁾
A, B	Service line (see port plates)			450	
T ₁	Drain line	DIN 3852 ⁶⁾	M12 x 1.5; 12 deep	3	X ⁵⁾
T ₂	Drain line	DIN 3852 ⁶⁾	M12 x 1.5; 12 deep	3	O ⁵⁾

- 1) To shaft collar
- 2) Center bore according to DIN 332 (thread according to DIN 13)
- 3) Observe the general instructions on page 46 for the maximum tightening torques.
- 4) Momentary pressure spikes may occur depending on the application. Keep this in mind when selecting measuring devices and fittings.
- 5) Depending on installation position, T₁ or T₂ must be connected (see also installation instructions on page 44).
- 6) The spot face can be deeper than specified in the appropriate standard.
- 7) O = Must be connected (plugged on delivery)
X = Plugged (in normal operation)

Dimensions sizes 10, 12, 16

Before finalizing your design, request a binding installation drawing. Dimensions in mm.

Location of the service line ports on the port plates

03 – Threaded ports at side, opposite

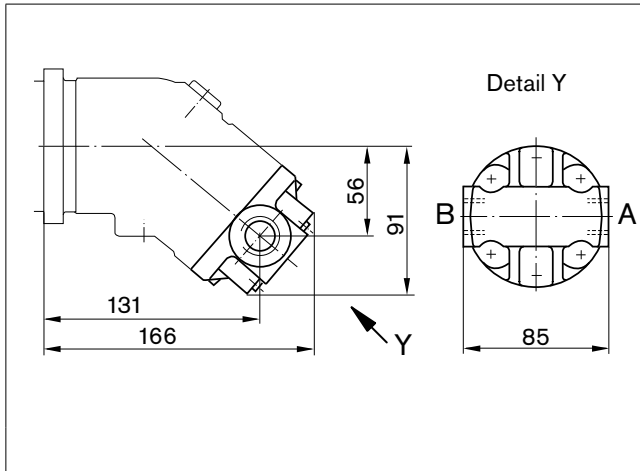

04 – Threaded ports at side and rear

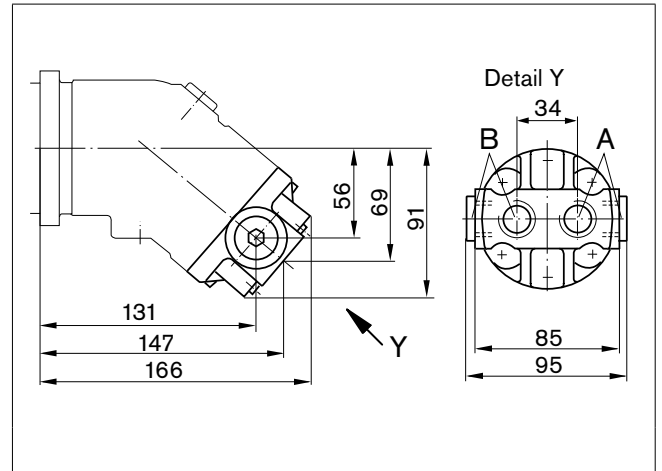

Plate	Designation	Port for	Standard ³⁾	Size ¹⁾	Maximum pressure [bar] ²⁾	State ⁴⁾
03	A, B	Service line	DIN 3852	M22 x 1.5; 14 deep	450	O
		Service line	DIN 3852	M22 x 1.5; 14 deep	450	1x O each

1) Observe the general instructions on page 46 for the maximum tightening torques

2) Momentary pressure spikes may occur depending on the application. Keep this in mind when selecting measuring devices and fittings.

3) The spot face can be deeper than specified in the appropriate standard.

4) O = Must be connected (plugged on delivery)

Dimensions sizes 23, 28, 32

Before finalizing your design, request a binding installation drawing. Dimensions in mm.

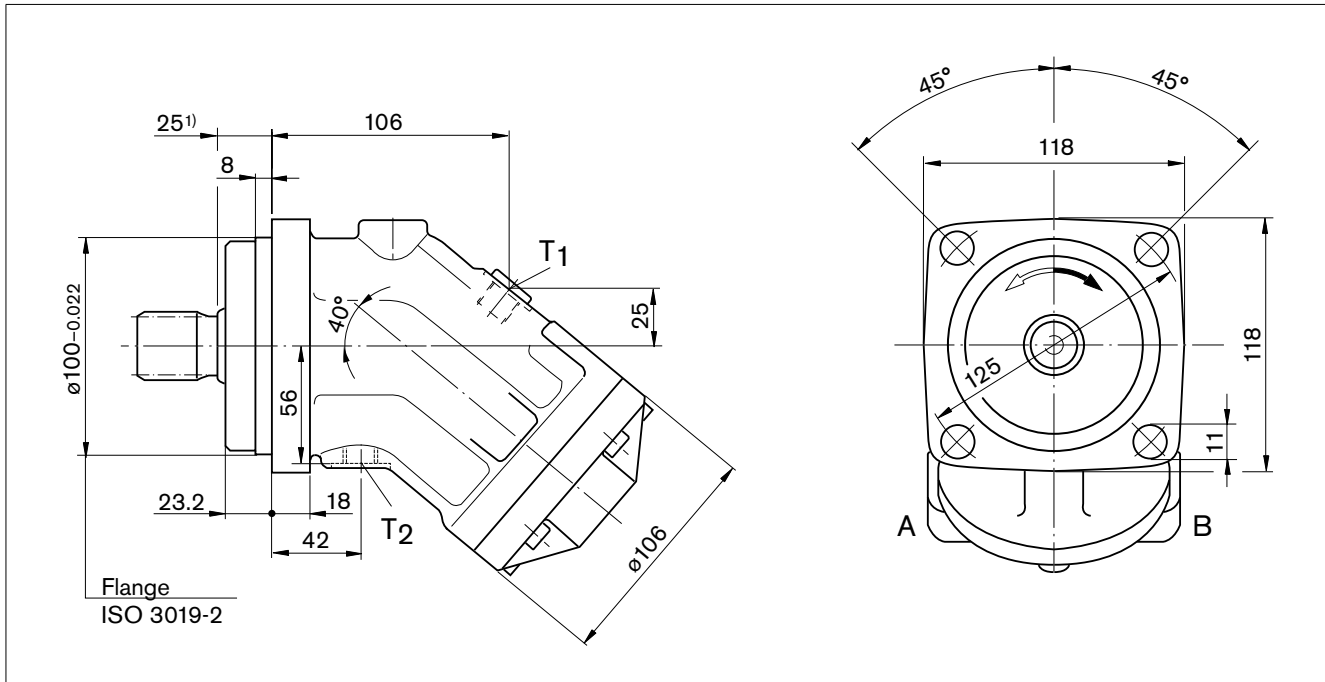

Drive shafts

Sizes 23, 28, 32

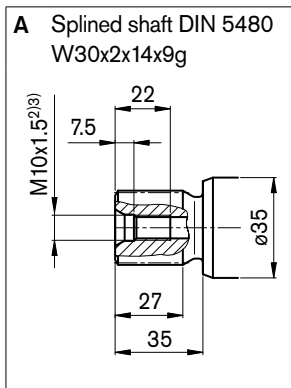

Sizes 23, 28

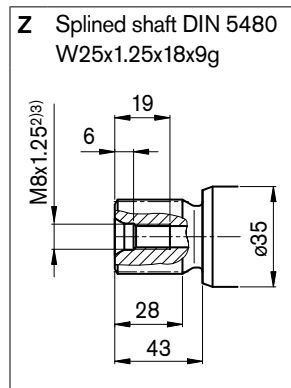

Sizes 23, 28, 32

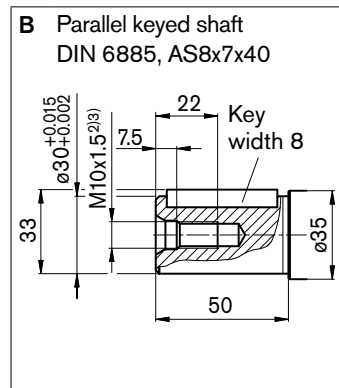

Sizes 23, 28

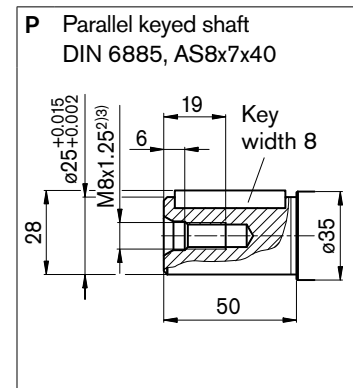

Ports

Designation	Port for	Standard	Size ³⁾	Maximum pressure [bar] ⁴⁾	State ⁷⁾
A, B	Service line (see port plates)			450	
T ₁	Drain line	DIN 3852 ⁶⁾	M16 x 1.5; 12 deep	3	X ⁵⁾
T ₂	Drain line	DIN 3852 ⁶⁾	M16 x 1.5; 12 deep	3	O ⁵⁾

- 1) To shaft collar
- 2) Center bore according to DIN 332 (thread according to DIN 13)
- 3) Observe the general instructions on page 46 for the maximum tightening torques.
- 4) Momentary pressure spikes may occur depending on the application. Keep this in mind when selecting measuring devices and fittings.
- 5) Depending on installation position, T₁ or T₂ must be connected (see also installation instructions on page 44).
- 6) The spot face can be deeper than specified in the appropriate standard.
- 7) O = Must be connected (plugged on delivery)
X = Plugged (in normal operation)

Dimensions sizes 23, 28, 32

Before finalizing your design, request a binding installation drawing. Dimensions in mm.

Location of the service line ports on the port plates

01 – SAE flange ports at rear

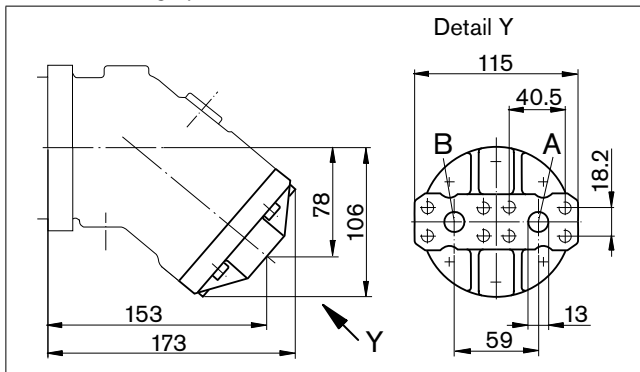

02 – SAE flange ports at side, opposite

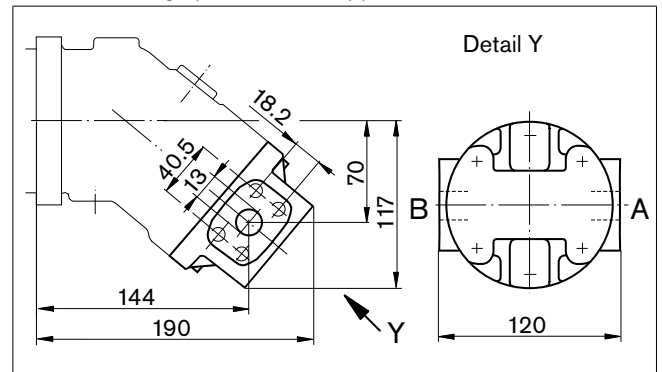

03 – Threaded ports at side, opposite

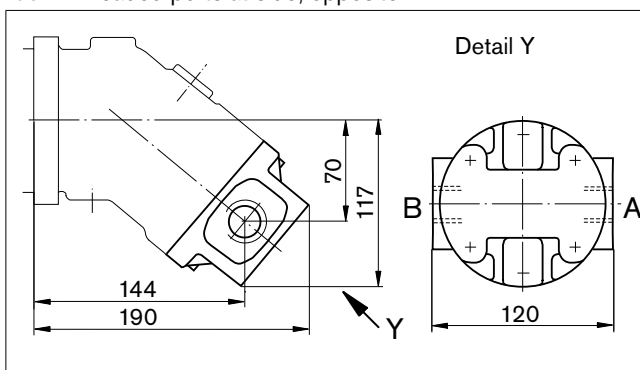

04 – Threaded ports at side and rear

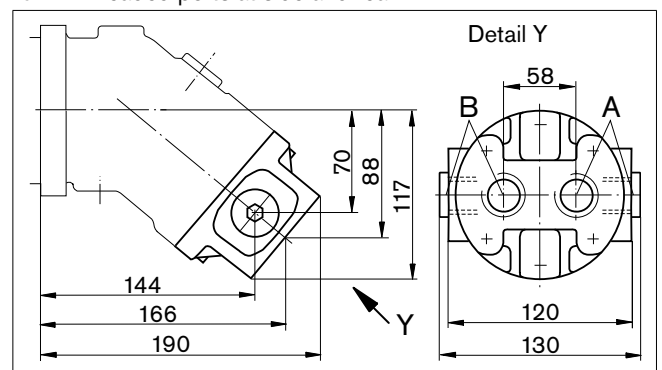

10 – SAE flange ports at bottom (same side)⁴⁾

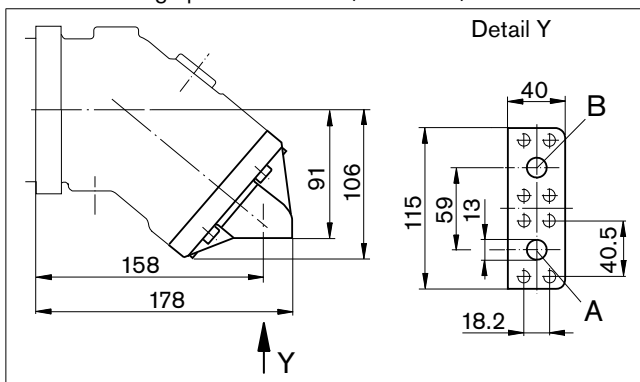

Plate	Designation	Port for	Standard	Size ¹⁾	Maximum pressure [bar] ²⁾	State ⁶⁾
01, 02, 10	A, B	Service line	SAE J518 ³⁾	1/2 in	450	O
		Fastening thread A/B	DIN 13	M8 x 1.25; 15 deep		
03		Service line	DIN 3852 ⁵⁾	M27 x 2; 16 deep	450	O
04		Service line	DIN 3852 ⁵⁾	M27 x 2; 16 deep	450	1x O each

1) Observe the general instructions on page 46 for the maximum tightening torques

2) Momentary pressure spikes may occur depending on the application. Keep this in mind when selecting measuring devices and fittings.

3) Only dimensions according to SAE J518, metric fastening thread is a deviation from standard

4) Only sizes 28 and 32

5) The spot face can be deeper than specified in the appropriate standard.

6) O = Must be connected (plugged on delivery)

Note

Port plates 18 and 19: see pages 37 and 40

Dimensions size 45

Before finalizing your design, request a binding installation drawing. Dimensions in mm.

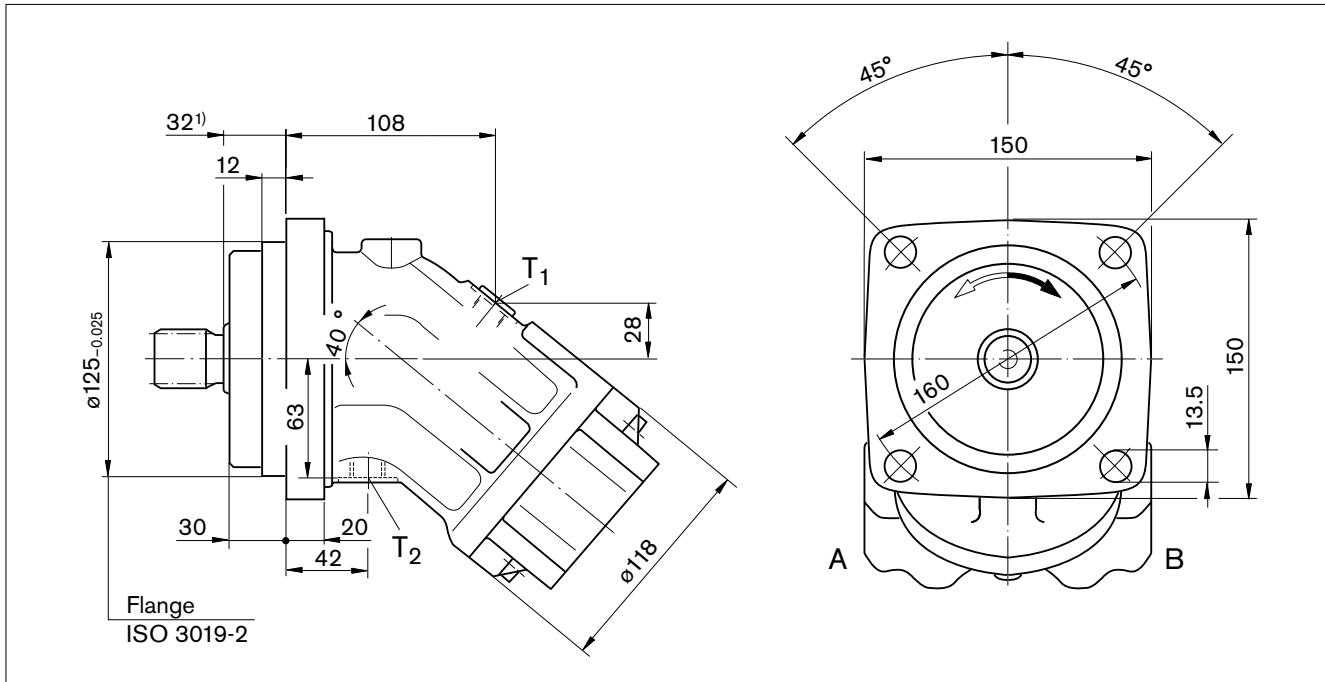

Drive shafts

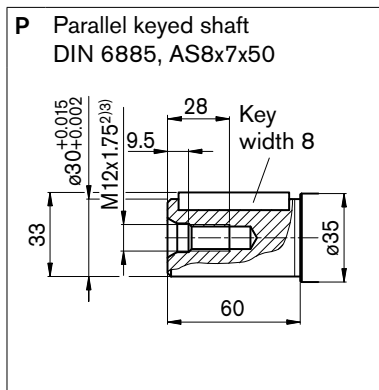
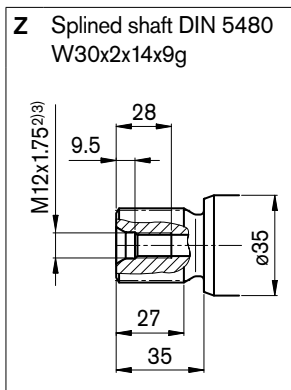

Ports

Designation	Port for	Standard	Size ³⁾	Maximum pressure [bar] ⁴⁾	State ⁷⁾
A, B	Service line (see port plates)			450	
T ₁	Drain line	DIN 3852 ⁶⁾	M18 x 1.5; 12 deep	3	X ⁵⁾
T ₂	Drain line	DIN 3852 ⁶⁾	M18 x 1.5; 12 deep	3	O ⁵⁾

- 1) To shaft collar
- 2) Center bore according to DIN 332 (thread according to DIN 13)
- 3) Observe the general instructions on page 46 for the maximum tightening torques.
- 4) Momentary pressure spikes may occur depending on the application. Keep this in mind when selecting measuring devices and fittings.
- 5) Depending on installation position, T₁ or T₂ must be connected (see also installation instructions on page 44).
- 6) The spot face can be deeper than specified in the appropriate standard.
- 7) O = Must be connected (plugged on delivery)
X = Plugged (in normal operation)

Dimensions size 45

Before finalizing your design, request a binding installation drawing. Dimensions in mm.

Location of the service line ports on the port plates

01 – SAE flange ports at rear

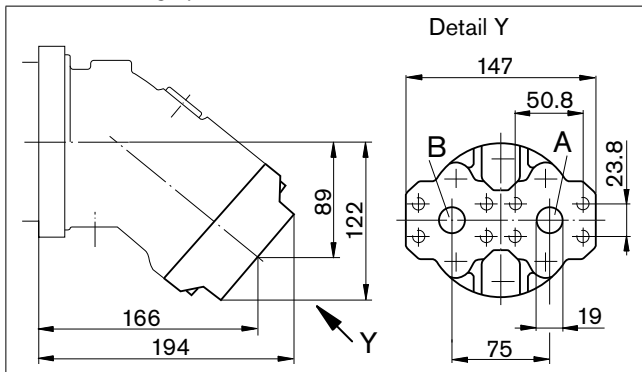

02 – SAE flange ports at side, opposite

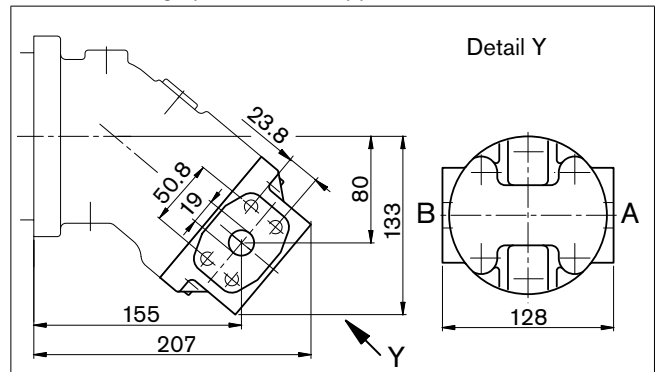

04 – Threaded ports at side and rear

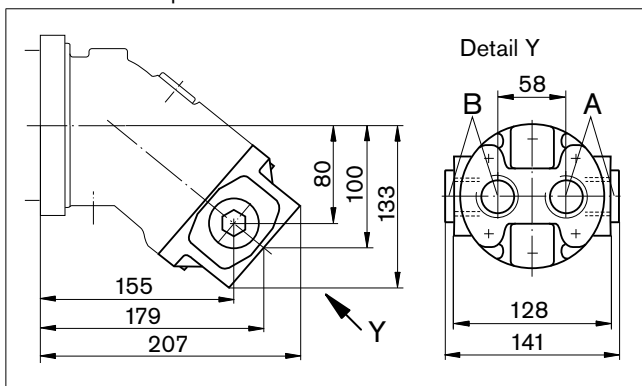

10 – SAE flange ports at bottom (same side)

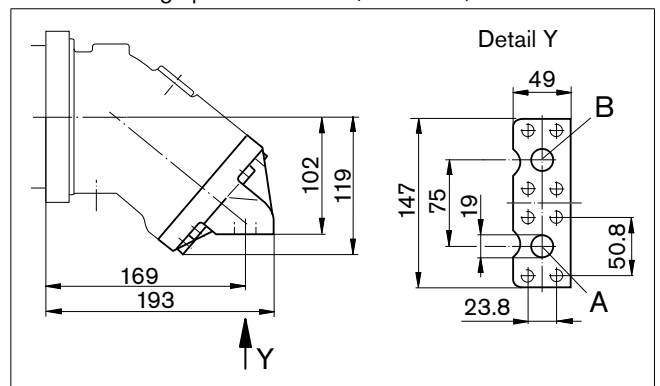

Plate	Designation	Port for	Standard	Size ¹⁾	Maximum pressure [bar] ²⁾	State ⁵⁾
01, 02, 10	A, B	Service line	SAE J518 ³⁾	3/4 in	450	O
		Fastening thread A/B	DIN 13	M10 x 1.5; 17 deep		
04		Service line	DIN 3852 ⁴⁾	M33 x 2; 18 deep	450	1x O each

- 1) Observe the general instructions on page 46 for the maximum tightening torques
- 2) Momentary pressure spikes may occur depending on the application. Keep this in mind when selecting measuring devices and fittings.
- 3) Only dimensions according to SAE J518, metric fastening thread is a deviation from standard.
- 4) The spot face can be deeper than specified in the appropriate standard.
- 5) O = Must be connected (plugged on delivery)

Note

Port plates 18 and 19: see pages 37 and 40

Dimensions sizes 56, 63

Before finalizing your design, request a binding installation drawing. Dimensions in mm.

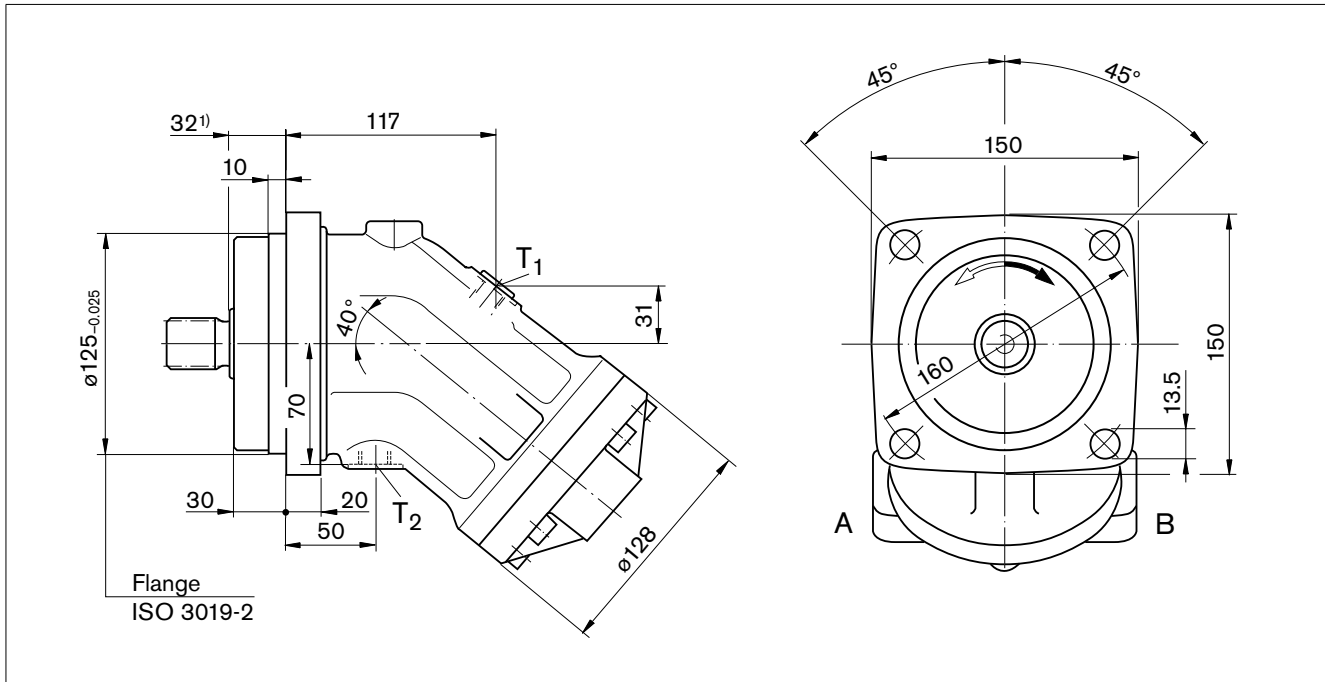

Drive shafts

NG56, 63

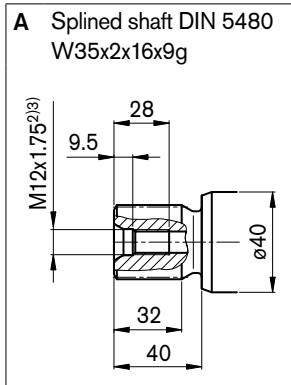

NG56

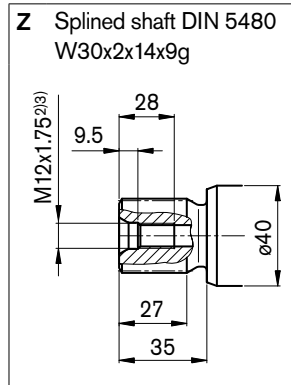

NG56, 63

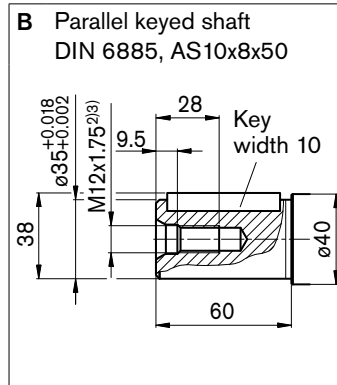

NG56

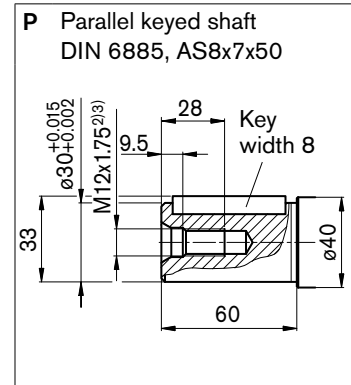

Ports

Designation	Port for	Standard	Size ⁽³⁾	Maximum pressure [bar] ⁽⁴⁾	State ⁽⁷⁾
A, B	Service line (see port plates)			450	
T ₁	Drain line	DIN 3852 ⁽⁶⁾	M18 x 1.5; 12 deep	3	X ⁽⁵⁾
T ₂	Drain line	DIN 3852 ⁽⁶⁾	M18 x 1.5; 12 deep	3	O ⁽⁵⁾

- 1) To shaft collar
- 2) Center bore according to DIN 332 (thread according to DIN 13)
- 3) Observe the general instructions on page 46 for the maximum tightening torques.
- 4) Momentary pressure spikes may occur depending on the application. Keep this in mind when selecting measuring devices and fittings.
- 5) Depending on installation position, T₁ or T₂ must be connected (see also installation instructions on page 44).
- 6) The spot face can be deeper than specified in the appropriate standard.
- 7) O = Must be connected (plugged on delivery)
X = Plugged (in normal operation)

Dimensions sizes 56, 63

Before finalizing your design, request a binding installation drawing. Dimensions in mm.

Location of the service line ports on the port plates

01 – SAE flange ports at rear

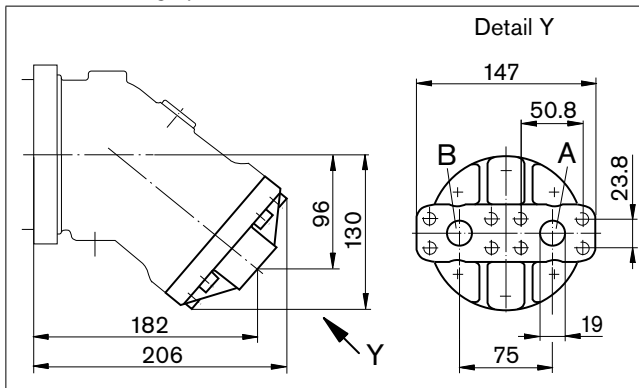

02 – SAE flange ports at side, opposite

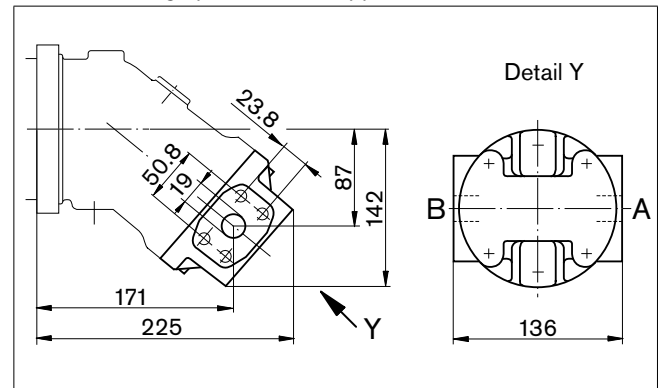

04 – Threaded ports at side and rear

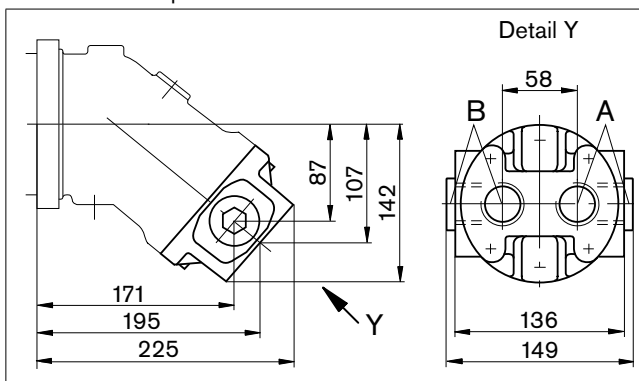

10 – SAE flange ports at bottom (same side)

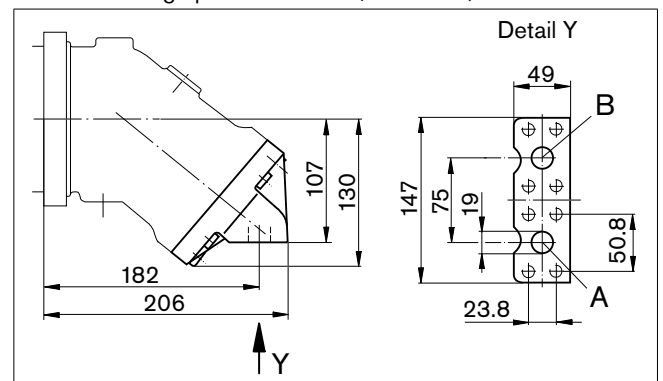

Plate	Designation	Port for	Standard	Size ¹⁾	Maximum pressure [bar] ²⁾	State ⁵⁾
01, 02, 10	A, B	Service line	SAE J518 ³⁾	3/4 in	450	O
		Fastening thread A/B	DIN 13	M10 x 1.5; 17 deep		
04		Service line	DIN 3852 ⁴⁾	M33 x 2; 18 deep	450	1x O each

1) Observe the general instructions on page 46 for the maximum tightening torques

2) Momentary pressure spikes may occur depending on the application. Keep this in mind when selecting measuring devices and fittings.

3) Only dimensions according to SAE J518, metric fastening thread is a deviation from standard.

4) The spot face can be deeper than specified in the appropriate standard.

5) O = Must be connected (plugged on delivery)

Note

Port plates 18 and 19: see pages 37 and 40

Dimensions sizes 80, 90

Before finalizing your design, request a binding installation drawing. Dimensions in mm.

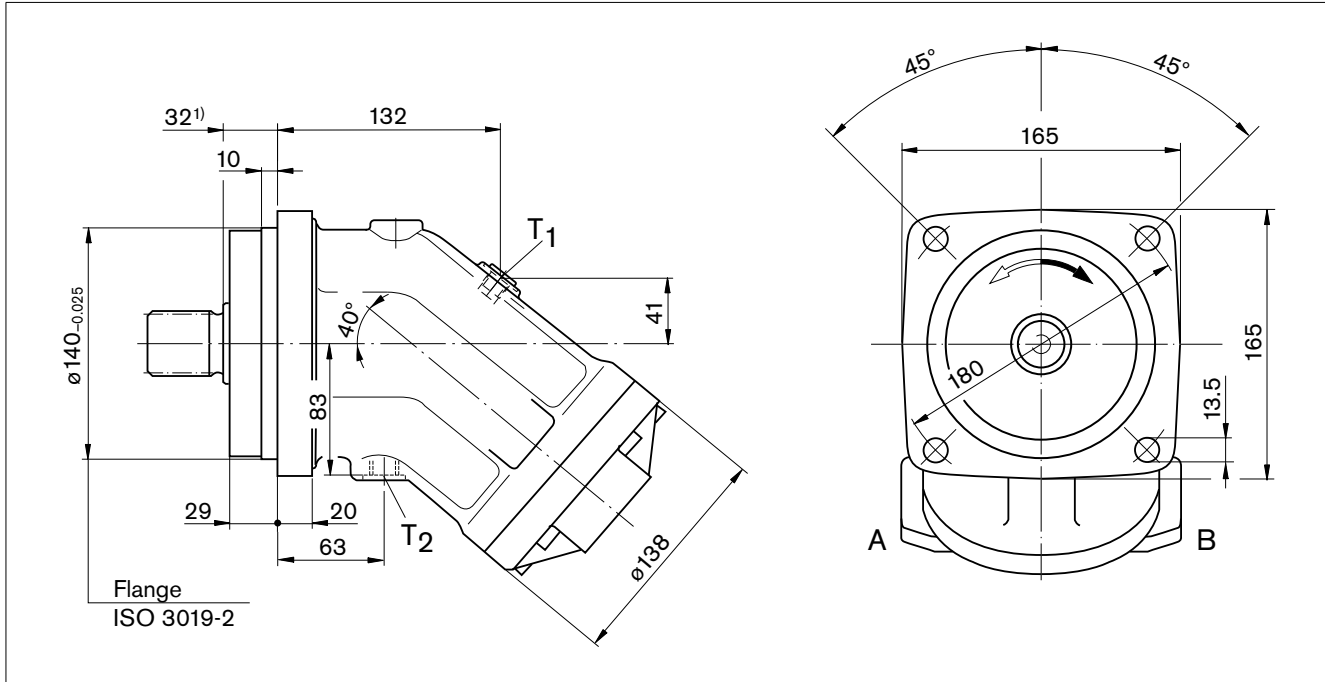

Drive shafts

NG80, 90

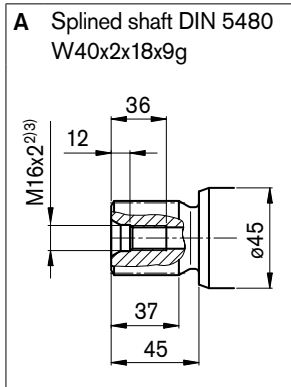

NG80

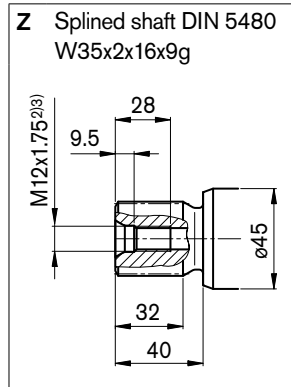

NG80, 90

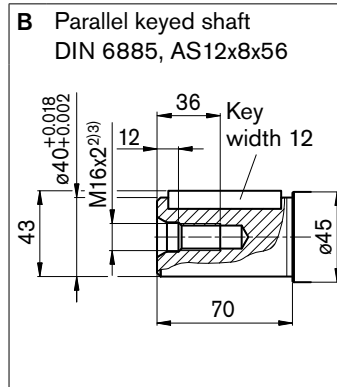

NG80

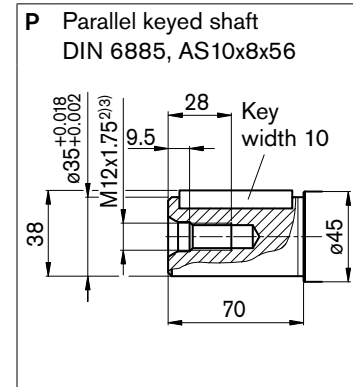

Ports

Designation	Port for	Standard	Size ³⁾	Maximum pressure [bar] ⁴⁾	State ⁷⁾
A, B	Service line (see port plates)			450	
T ₁	Drain line	DIN 3852 ⁶⁾	M18 x 1.5; 12 deep	3	X ⁵⁾
T ₂	Drain line	DIN 3852 ⁶⁾	M18 x 1.5; 12 deep	3	O ⁵⁾

- 1) To shaft collar
- 2) Center bore according to DIN 332 (thread according to DIN 13)
- 3) Observe the general instructions on page 46 for the maximum tightening torques.
- 4) Momentary pressure spikes may occur depending on the application. Keep this in mind when selecting measuring devices and fittings.
- 5) Depending on installation position, T₁ or T₂ must be connected (see also installation instructions on page 44).
- 6) The spot face can be deeper than specified in the appropriate standard.
- 7) O = Must be connected (plugged on delivery)
X = Plugged (in normal operation)

Dimensions sizes 80, 90

Before finalizing your design, request a binding installation drawing. Dimensions in mm.

Location of the service line ports on the port plates

01 – SAE flange ports at rear

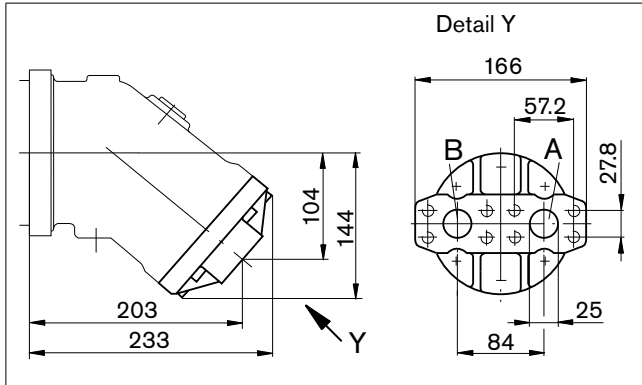

02 – SAE flange ports at side, opposite

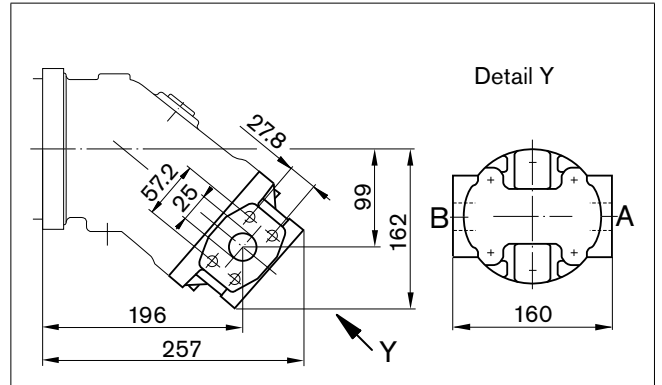

10 – SAE flange ports at bottom (same side)

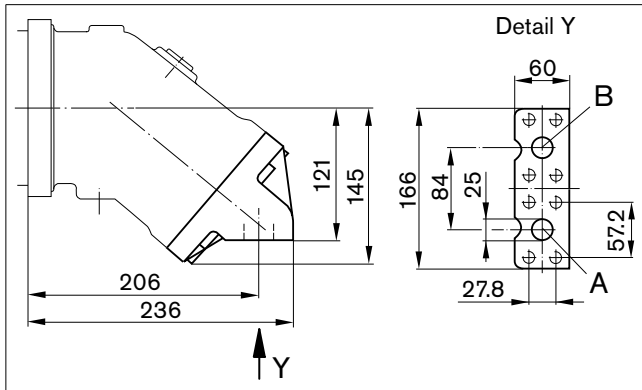

Plate	Designation	Port for	Standard	Size ¹⁾	Maximum pressure [bar] ²⁾	State ⁴⁾
01, 02, 10	A, B	Service line Fastening thread A/B	SAE J518 ³⁾ DIN 13	1 in M12 x 1.75; 17 deep	450	O

- 1) Observe the general instructions on page 46 for the maximum tightening torques
- 2) Momentary pressure spikes may occur depending on the application. Keep this in mind when selecting measuring devices and fittings.
- 3) Only dimensions according to SAE J518, metric fastening thread is a deviation from standard.
- 4) O = Must be connected (plugged on delivery)

Note

Port plates 18 and 19: see pages 37 and 40

Dimensions sizes 107, 125

Before finalizing your design, request a binding installation drawing. Dimensions in mm.

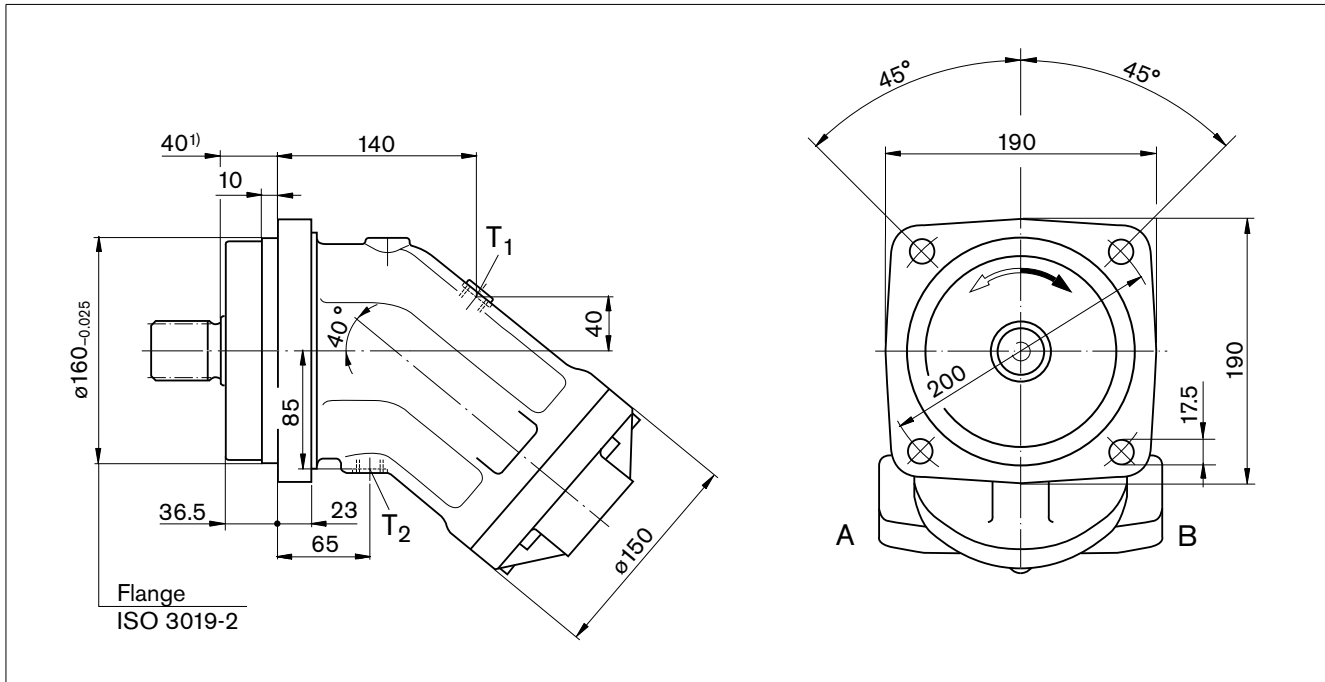

Drive shafts

NG107, 125

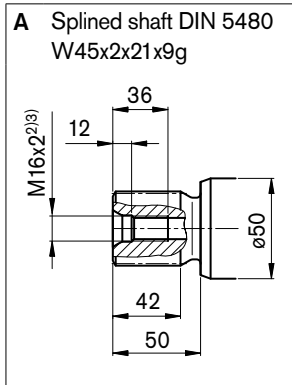

NG107

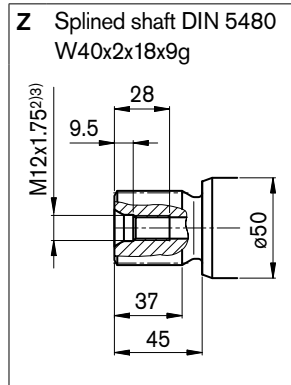

NG107, 125

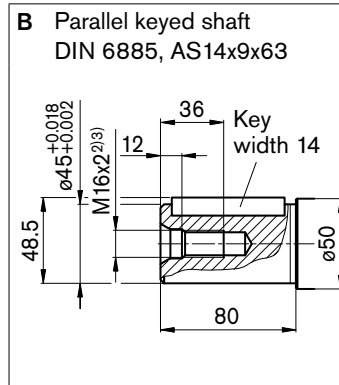

NG107

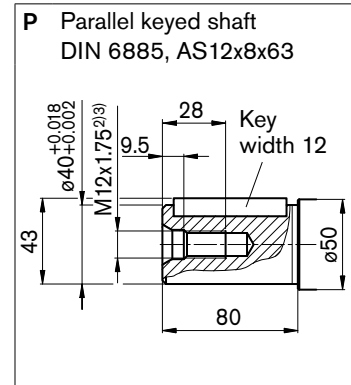

Ports

Designation	Port for	Standard	Size ³⁾	Maximum pressure [bar] ⁴⁾	State ⁷⁾
A, B	Service line (see port plates)			450	
T ₁	Drain line	DIN 3852 ⁶⁾	M18 x 1.5; 12 deep	3	X ⁵⁾
T ₂	Drain line	DIN 3852 ⁶⁾	M18 x 1.5; 12 deep	3	O ⁵⁾

- 1) To shaft collar
- 2) Center bore according to DIN 332 (thread according to DIN 13)
- 3) Observe the general instructions on page 46 for the maximum tightening torques.
- 4) Momentary pressure spikes may occur depending on the application. Keep this in mind when selecting measuring devices and fittings.
- 5) Depending on installation position, T₁ or T₂ must be connected (see also installation instructions on page 44).
- 6) The spot face can be deeper than specified in the appropriate standard.
- 7) O = Must be connected (plugged on delivery)
X = Plugged (in normal operation)

Dimensions sizes 107, 125

Before finalizing your design, request a binding installation drawing. Dimensions in mm.

Location of the service line ports on the port plates

01 – SAE flange ports at rear

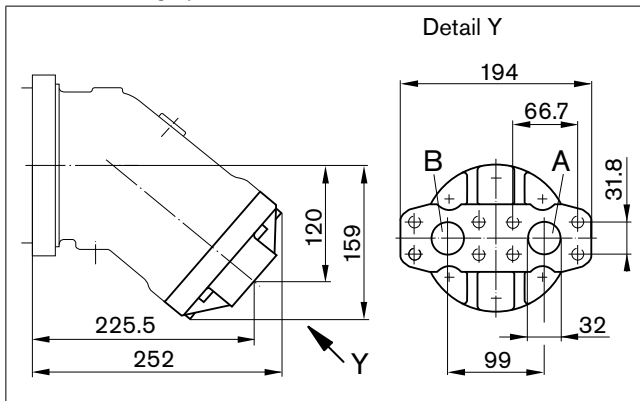

02 – SAE flange ports at side, opposite (size 107)

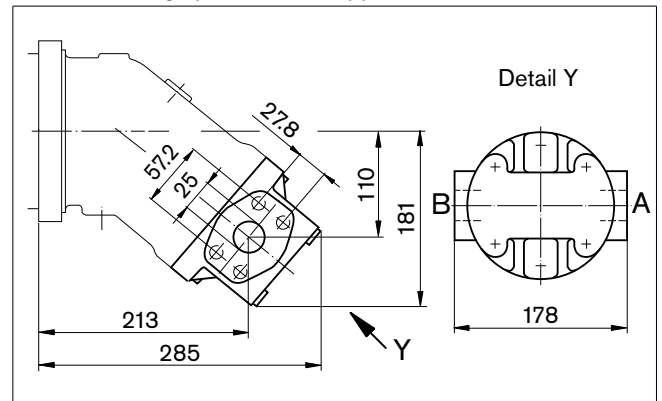

10 – SAE flange ports at bottom (same side)

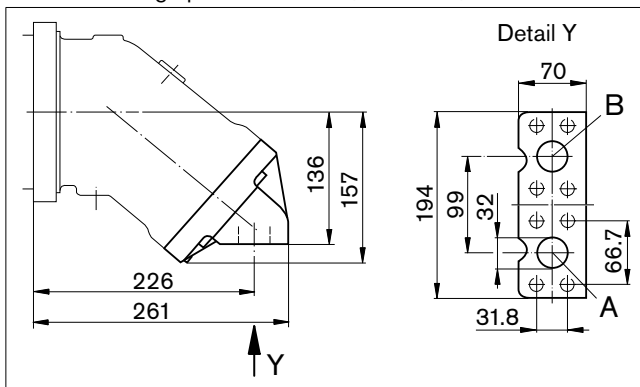

02 – SAE flange ports at side, opposite (size 125)

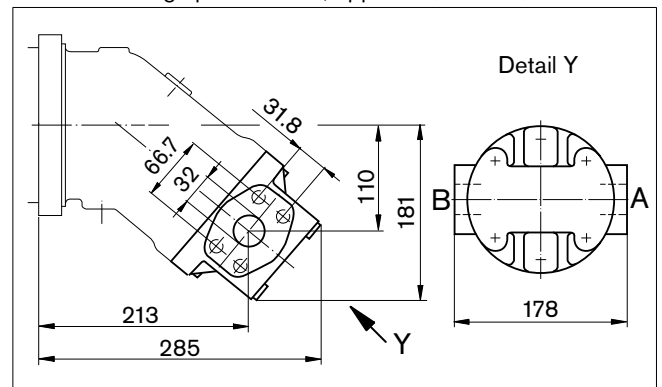

Plate	Designation	Port for	Standard	Size ¹⁾	Maximum pressure [bar] ²⁾	State ⁴⁾
01, 10	A, B	Service line	SAE J518 ³⁾	1 1/4 in	450	O
		Fastening thread A/B	DIN 13	M14 x 2; 19 deep		
02 (size 107)		Service line	SAE J518 ³⁾	1 in	450	O
		Fastening thread A/B	DIN 13	M12 x 1.75; 17 deep		
02 (size 125)		Service line	SAE J518 ³⁾	1 1/4 in	450	O
		Fastening thread A/B	DIN 13	M14 x 2; 19 deep		

- 1) Observe the general instructions on page 46 for the maximum tightening torques
- 2) Momentary pressure spikes may occur depending on the application. Keep this in mind when selecting measuring devices and fittings.
- 3) Only dimensions according to SAE J518, metric fastening thread is a deviation from standard.
- 4) O = Must be connected (plugged on delivery)

Note

Port plates 17, 18 and 19: see pages 37 and 40

Dimensions sizes 160, 180

Before finalizing your design, request a binding installation drawing. Dimensions in mm.

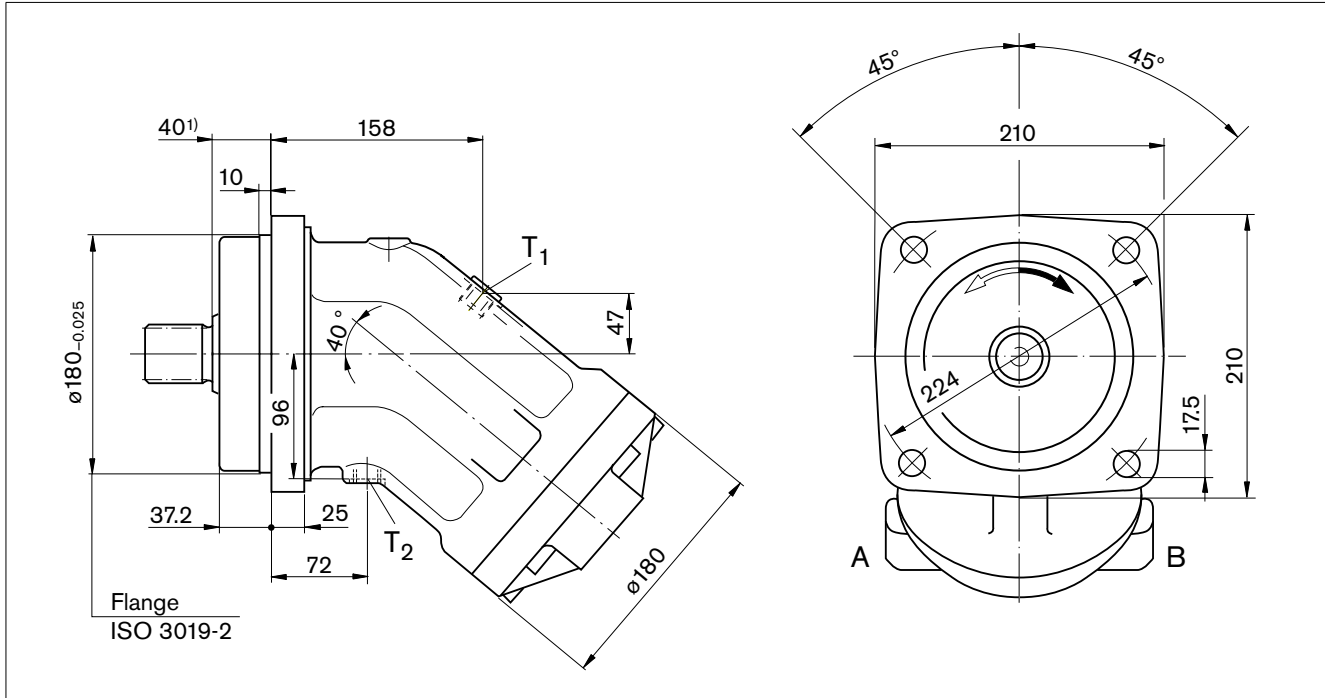

Drive shafts

NG160, 180

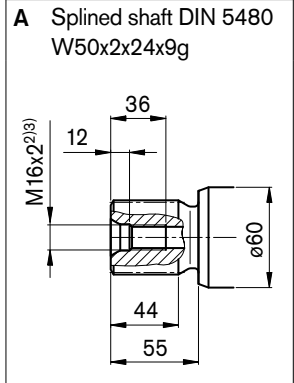

NG160

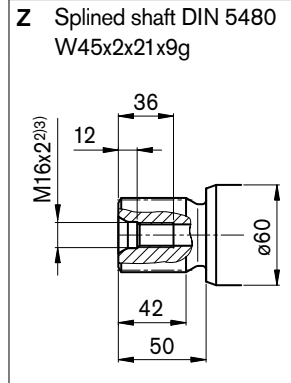

NG160, 180

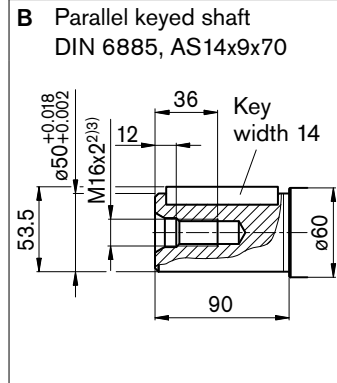

NG160

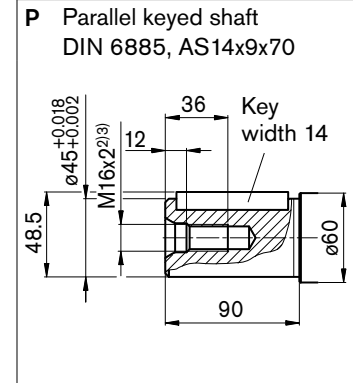

Ports

Designation	Port for	Standard	Size ³⁾	Maximum pressure [bar] ⁴⁾	State ⁷⁾
A, B	Service line (see port plates)			450	
T ₁	Drain line	DIN 3852 ⁶⁾	M22 x 1.5; 14 deep	3	X ⁵⁾
T ₂	Drain line	DIN 3852 ⁶⁾	M22 x 1.5; 14 deep	3	O ⁵⁾

- 1) To shaft collar
- 2) Center bore according to DIN 332 (thread according to DIN 13)
- 3) Observe the general instructions on page 46 for the maximum tightening torques.
- 4) Momentary pressure spikes may occur depending on the application. Keep this in mind when selecting measuring devices and fittings.
- 5) Depending on installation position, T₁ or T₂ must be connected (see also installation instructions on page 44).
- 6) The spot face can be deeper than specified in the appropriate standard.
- 7) O = Must be connected (plugged on delivery)
X = Plugged (in normal operation)

Dimensions sizes 160, 180

Before finalizing your design, request a binding installation drawing. Dimensions in mm.

Location of the service line ports on the port plates

01 – SAE flange ports at rear

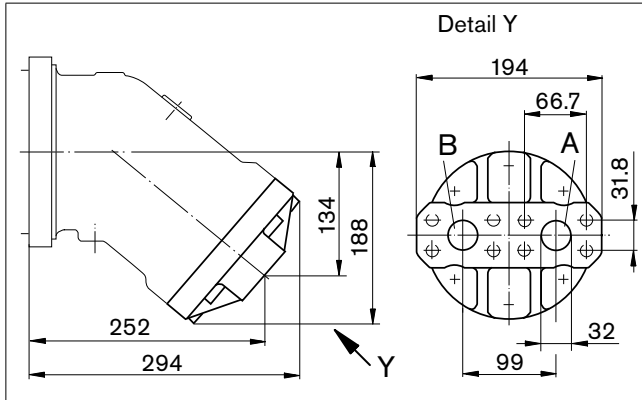

02 – SAE flange ports at side, opposite

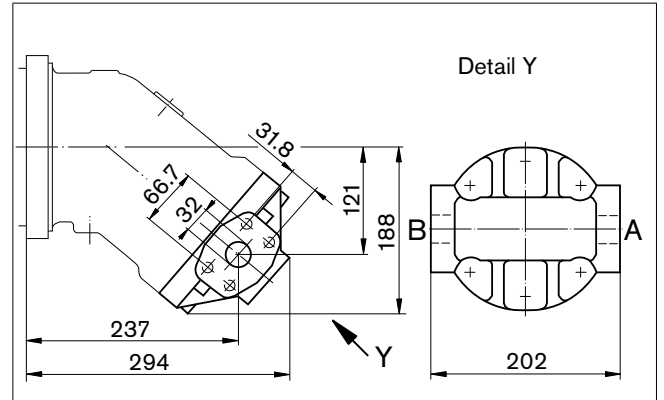

10 – SAE flange ports at bottom (same side)

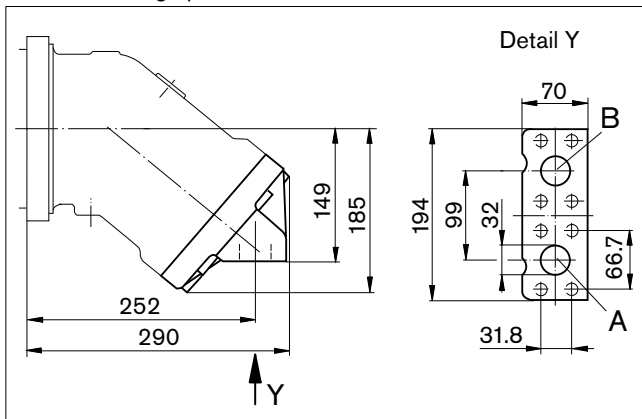

Plate	Designation	Port for	Standard	Size ¹⁾	Maximum pressure [bar] ²⁾	State ⁴⁾
01, 02, 10	A, B	Service line Fastening thread A/B	SAE J518 ³⁾ DIN 13	1 1/4 in M14 x 2; 19 deep	450	O

- 1) Observe the general instructions on page 46 for the maximum tightening torques
- 2) Momentary pressure spikes may occur depending on the application. Keep this in mind when selecting measuring devices and fittings.
- 3) Only dimensions according to SAE J518, metric fastening thread is a deviation from standard.
- 4) O = Must be connected (plugged on delivery)

Note

Port plates 18 and 19: see pages 37 and 40

Dimensions size 200

Before finalizing your design, request a binding installation drawing. Dimensions in mm.

Port plate 01 – SAE flange ports at rear

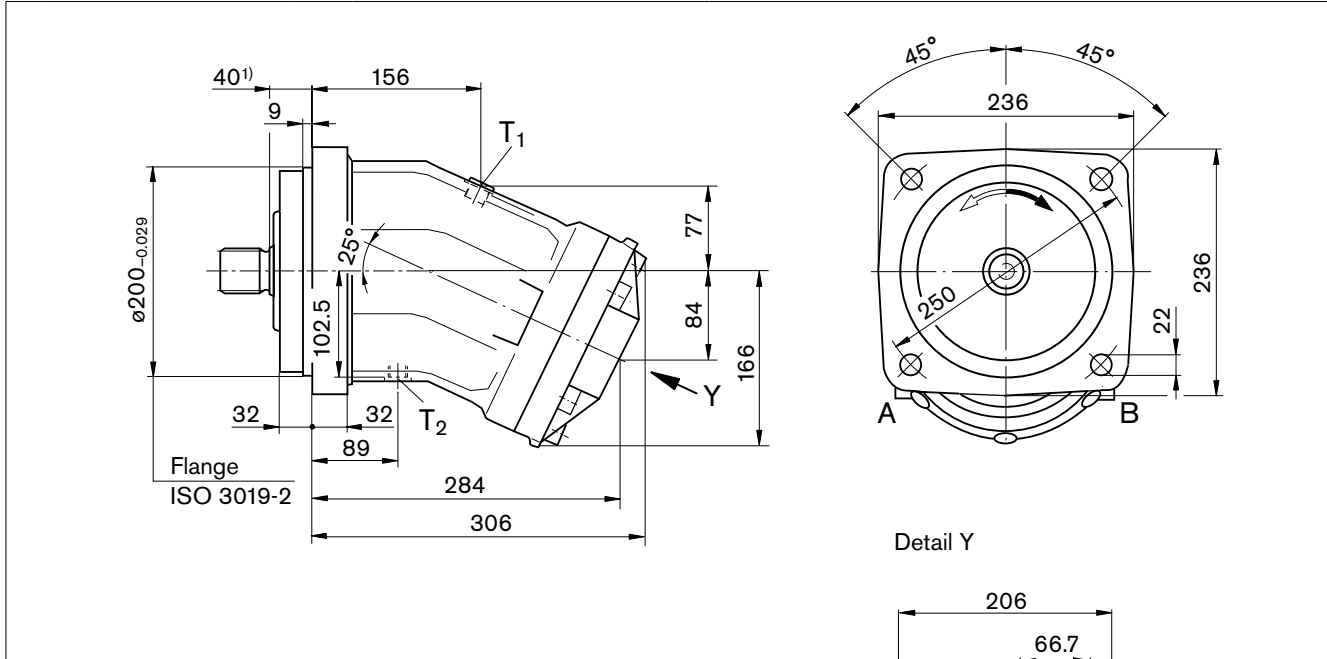

Drive shafts

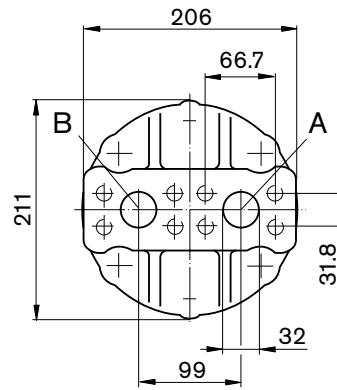
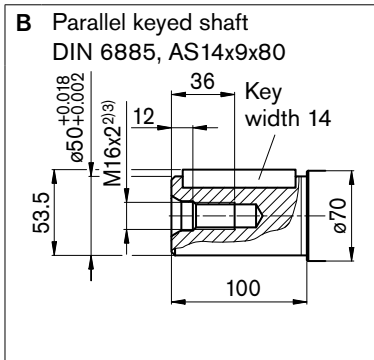
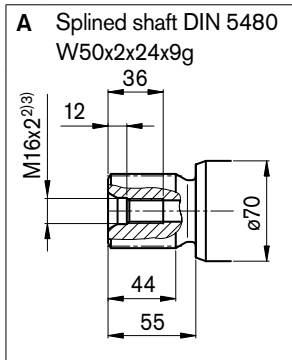

Ports

Designation	Port for	Standard	Size ⁽³⁾	Maximum pressure [bar] ⁽⁴⁾	State ⁽⁸⁾
A, B	Service line Fastening thread A/B	SAE J5185 ⁽¹⁾ DIN 13	1 1/4 in M14 x 2; 19 deep	450	O
T ₁	Drain line	DIN 3852 ⁽⁷⁾	M22 x 1.5; 14 deep	3	X ⁽⁶⁾
T ₂	Drain line	DIN 3852 ⁽⁷⁾	M22 x 1.5; 14 deep	3	O ⁽⁶⁾

- 1) To shaft collar
- 2) Center bore according to DIN 332 (thread according to DIN 13)
- 3) Observe the general instructions on page 46 for the maximum tightening torques.
- 4) Momentary pressure spikes may occur depending on the application. Keep this in mind when selecting measuring devices and fittings.
- 5) Only dimensions according to SAE J518, metric fastening thread is a deviation from standard.
- 6) Depending on installation position, T₁ or T₂ must be connected (see also installation instructions on page 44).
- 7) The spot face can be deeper than specified in the appropriate standard.
- 8) O = Must be connected (plugged on delivery)
X = Plugged (in normal operation)

Notes

Dimensions size 250

Before finalizing your design, request a binding installation drawing. Dimensions in mm.

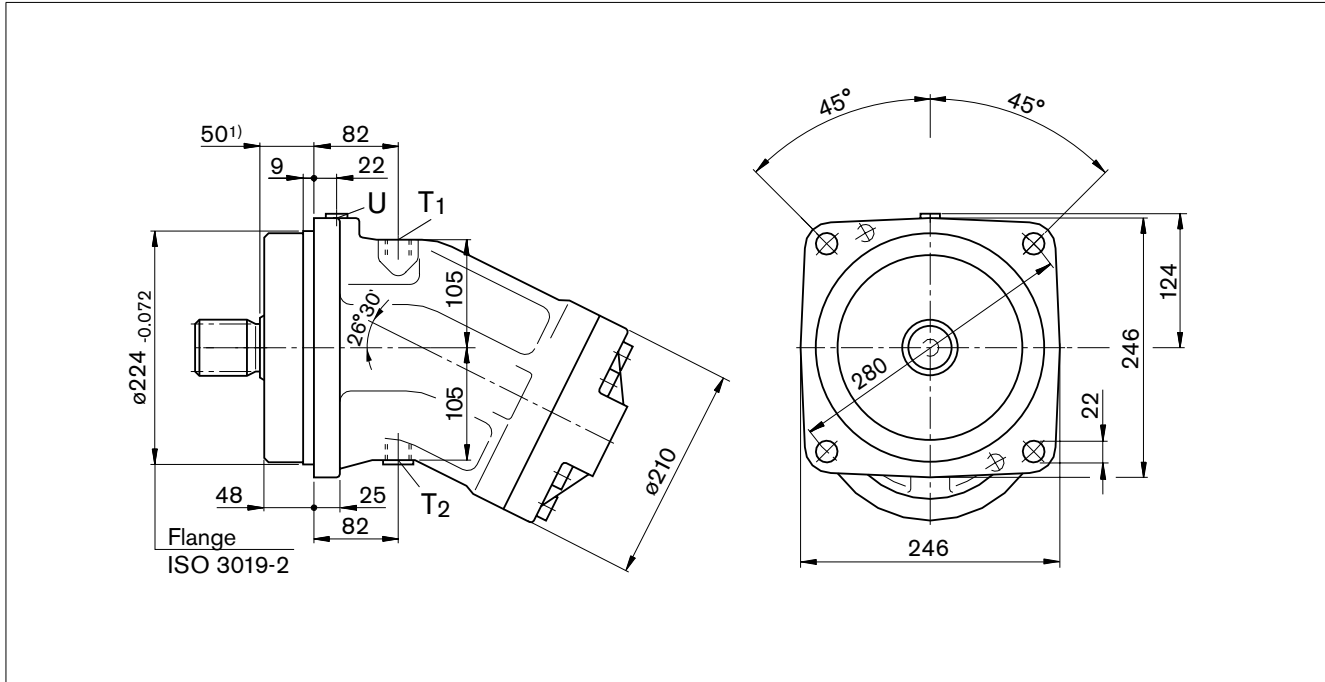

Drive shafts

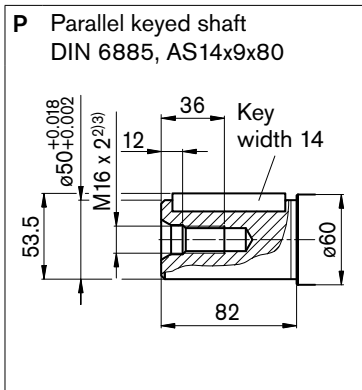
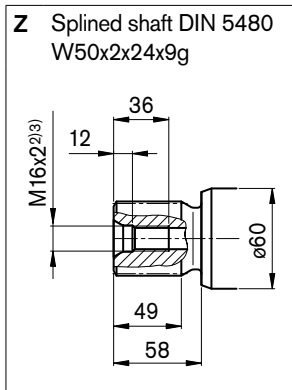

Ports

Designation	Port for	Standard	Size ³⁾	Maximum pressure [bar] ⁴⁾	State ⁷⁾
A, B	Service line (see port plates)			400	
T ₁	Drain line	DIN 3852 ⁶⁾	M22 x 1.5; 14 deep	3	O ⁵⁾
T ₂	Drain line	DIN 3852 ⁶⁾	M22 x 1.5; 14 deep	3	X ⁵⁾
U	Bearing flushing	DIN 3852 ⁶⁾	M14 x 1.5; 12 deep	3	X

- 1) To shaft collar
- 2) Center bore according to DIN 332 (thread according to DIN 13)
- 3) Observe the general instructions on page 46 for the maximum tightening torques.
- 4) Momentary pressure spikes may occur depending on the application. Keep this in mind when selecting measuring devices and fittings.
- 5) Depending on installation position, T₁ or T₂ must be connected (see also installation instructions on page 44).
- 6) The spot face can be deeper than specified in the appropriate standard.
- 7) O = Must be connected (plugged on delivery)
X = Plugged (in normal operation)

Dimensions size 250

Before finalizing your design, request a binding installation drawing. Dimensions in mm.

Location of the service line ports on the port plates

01 – SAE flange ports at rear

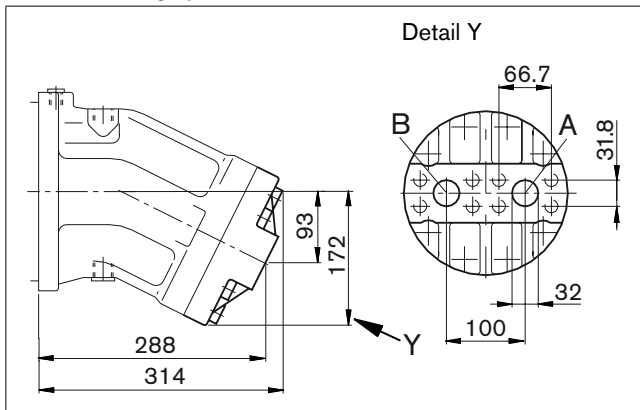

02 – SAE flange ports at side, opposite

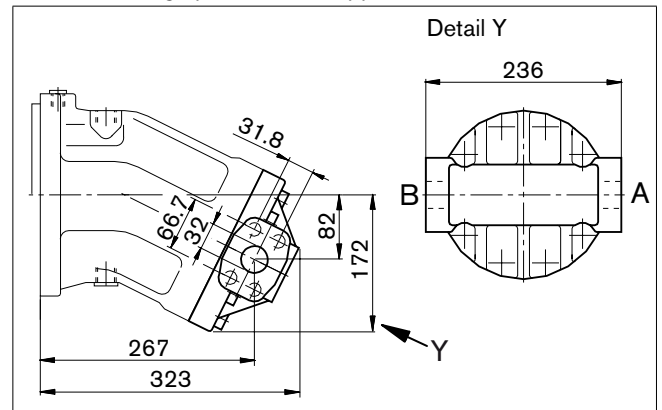

Plate	Designation	Port for	Standard	Size ¹⁾	Maximum pressure [bar] ²⁾	State ⁴⁾
01, 02	A, B	Service line Fastening thread A/B	SAE J518 ³⁾ DIN 13	1 1/4 in M14 x 2; 19 deep	400	O

1) Observe the general instructions on page 46 for the maximum tightening torques

2) Momentary pressure spikes may occur depending on the application. Keep this in mind when selecting measuring devices and fittings.

3) Only dimensions according to SAE J518, metric fastening thread is a deviation from standard.

4) O = Must be connected (plugged on delivery)

Dimensions size 355

Before finalizing your design, request a binding installation drawing. Dimensions in mm.

Port plate 01 – SAE flange ports at rear

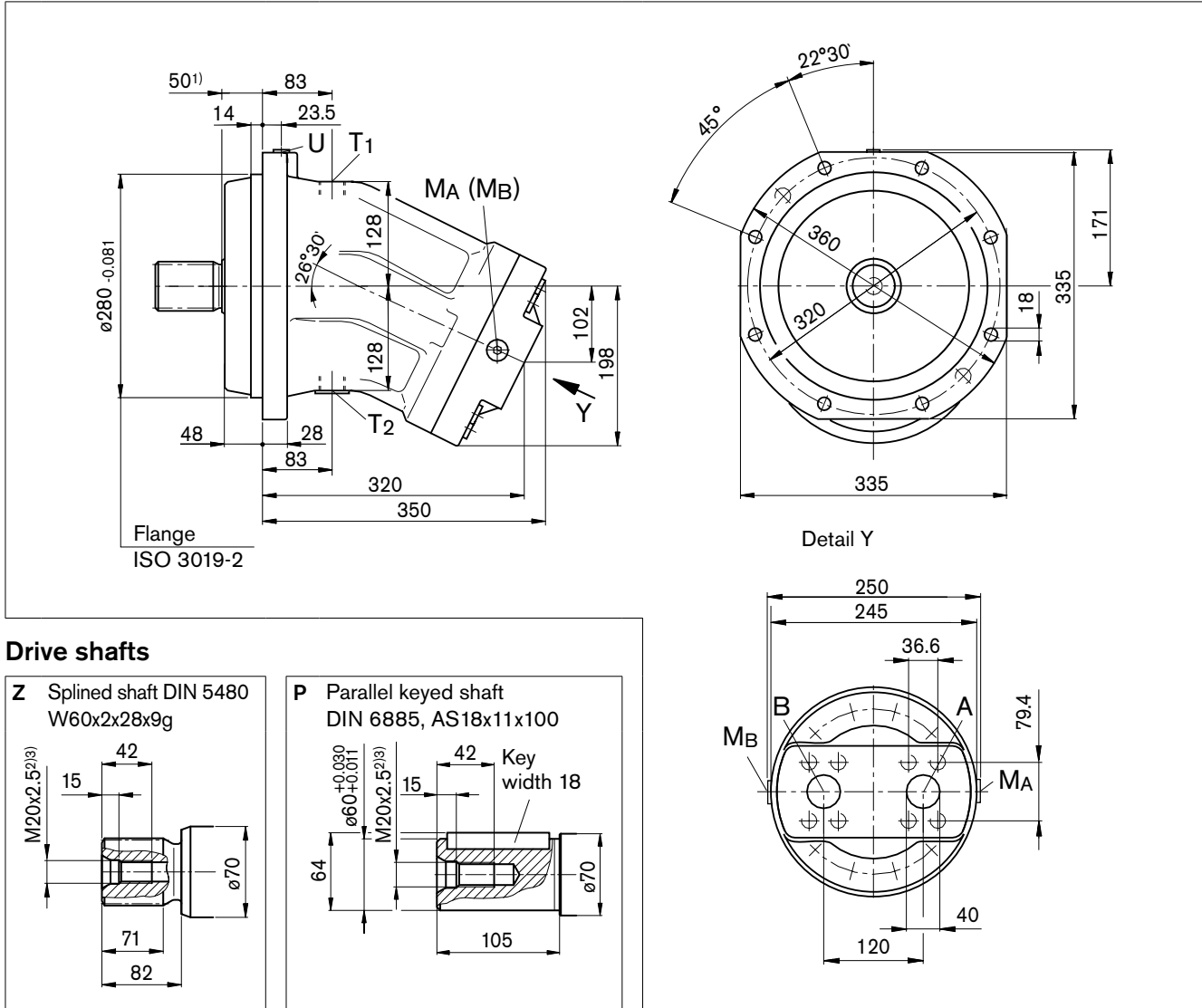

Drive shafts

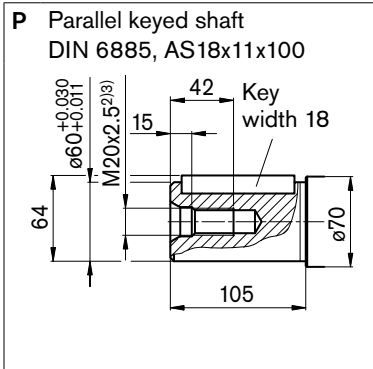
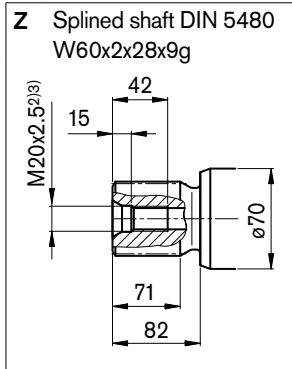

Ports

Designation	Port for	Standard	Size ³⁾	Maximum pressure [bar] ⁴⁾	State ⁸⁾
A, B	Service line Fastening thread A/B	SAE J5185 ⁵⁾ DIN 13	1 1/2 in M16 x 2; 21 deep	400	O
T ₁	Drain line	DIN 3852 ⁷⁾	M33 x 2; 18 deep	3	O ⁶⁾
T ₂	Drain line	DIN 3852 ⁷⁾	M33 x 2; 18 deep	3	X ⁶⁾
U	Bearing flushing	DIN 3852 ⁷⁾	M14 x 1.5; 12 deep	3	X
M _A , M _B	Measuring operating pressure	DIN 3852 ⁷⁾	M14 x 1.5; 12 deep	400	X

- 1) To shaft collar
- 2) Center bore according to DIN 332 (thread according to DIN 13)
- 3) Observe the general instructions on page 46 for the maximum tightening torques.
- 4) Momentary pressure spikes may occur depending on the application. Keep this in mind when selecting measuring devices and fittings.
- 5) Only dimensions according to SAE J518, metric fastening thread is a deviation from standard.
- 6) Depending on installation position, T₁ or T₂ must be connected (see also installation instructions on page 44).
- 7) The spot face can be deeper than specified in the appropriate standard.
- 8) O = Must be connected (plugged on delivery)
X = Plugged (in normal operation)

Dimensions size 500

Before finalizing your design, request a binding installation drawing. Dimensions in mm.

Port plate 01 – SAE flange ports at rear

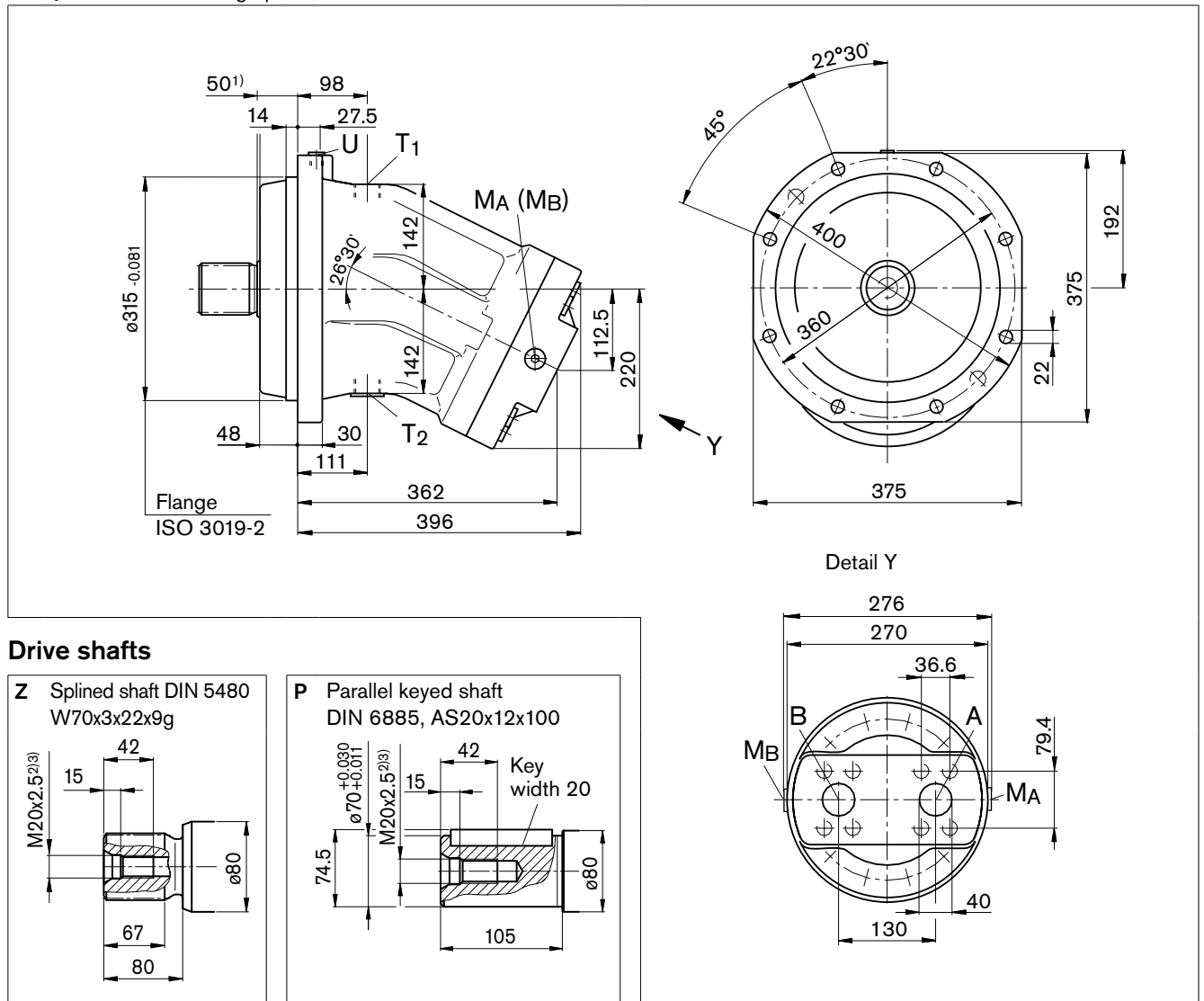

Ports

Designation	Port for	Standard	Size ³⁾	Maximum pressure [bar] ⁴⁾	State ⁸⁾
A, B	Service line Fastening thread A/B	SAE J5185 ⁵⁾ DIN 13	1 1/2 in M16 x 2; 21 deep	400	O
T ₁	Drain line	DIN 3852 ⁷⁾	M33 x 2; 18 deep	3	O ⁶⁾
T ₂	Drain line	DIN 3852 ⁷⁾	M33 x 2; 18 deep	3	X ⁶⁾
U	Bearing flushing	DIN 3852 ⁷⁾	M18 x 1.5; 12 deep	3	X
M _A , M _B	Measuring operating pressure	DIN 3852 ⁷⁾	M14 x 1.5; 12 deep	400	X

- 1) To shaft collar
- 2) Center bore according to DIN 332 (thread according to DIN 13)
- 3) Observe the general instructions on page 46 for the maximum tightening torques.
- 4) Momentary pressure spikes may occur depending on the application. Keep this in mind when selecting measuring devices and fittings.
- 5) Only dimensions according to SAE J518, metric fastening thread is a deviation from standard.
- 6) Depending on installation position, T₁ or T₂ must be connected (see also installation instructions on page 44).
- 7) The spot face can be deeper than specified in the appropriate standard.
- 8) O = Must be connected (plugged on delivery)
X = Plugged (in normal operation)

Dimensions size 710

Before finalizing your design, request a binding installation drawing. Dimensions in mm.

Port plate 01 – SAE flange ports at rear

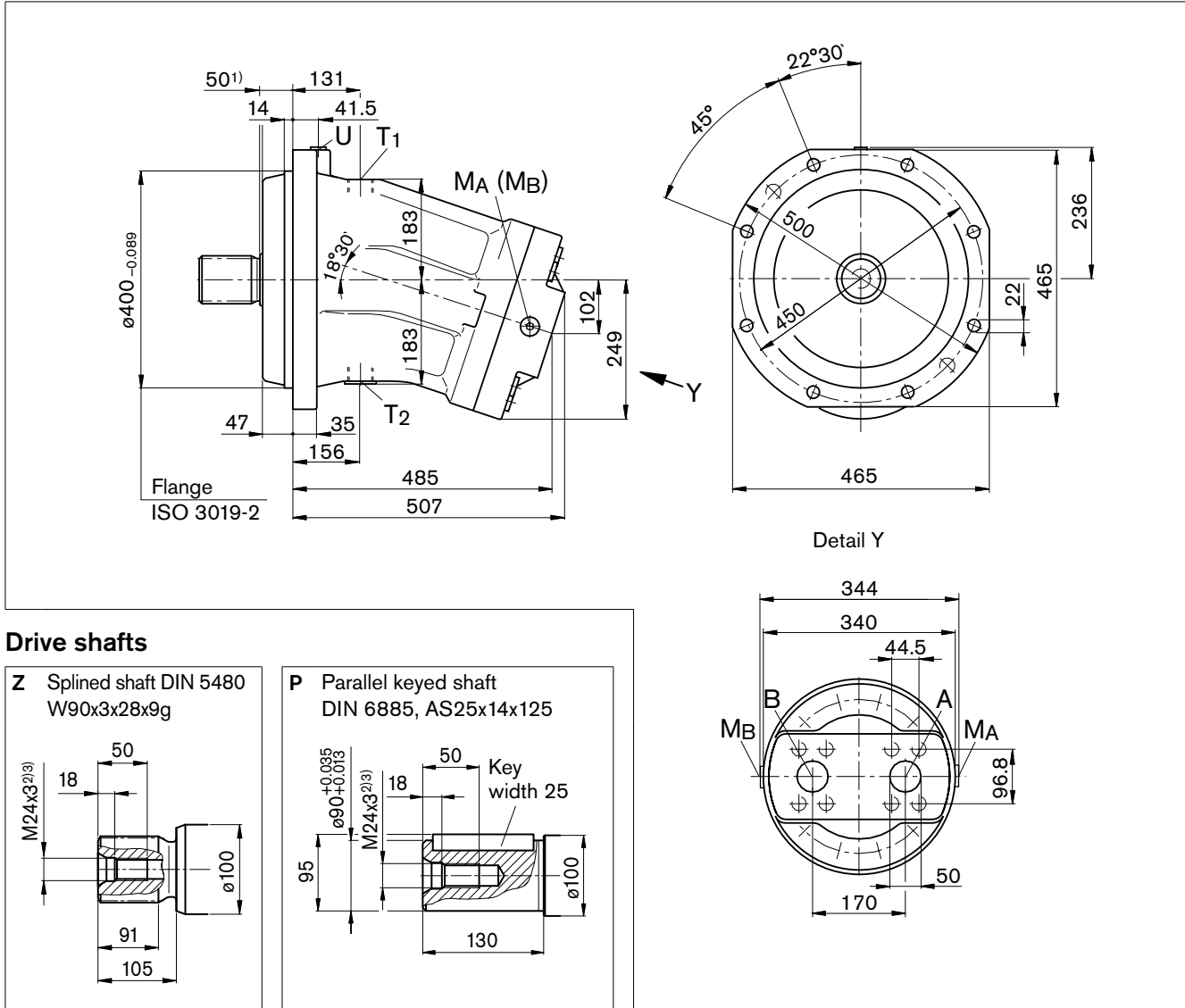

Drive shafts

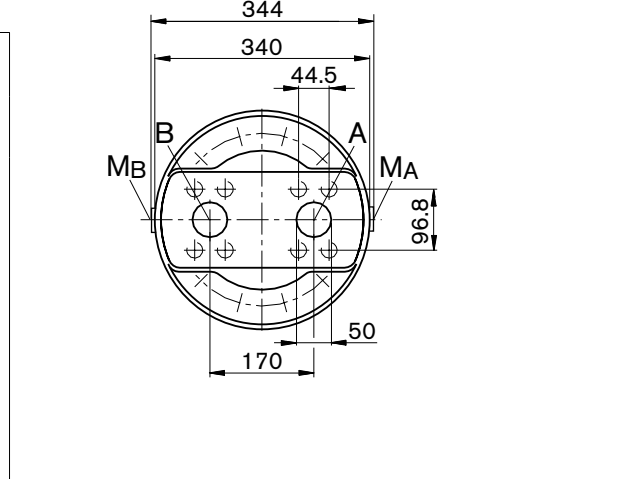
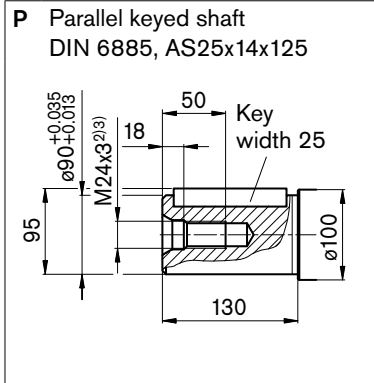
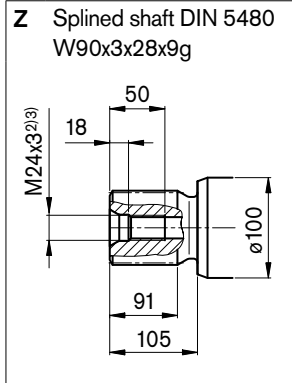

Ports

Designation	Port for	Standard	Size ³⁾	Maximum pressure [bar] ⁴⁾	State ⁸⁾
A, B	Service line Fastening thread A/B	SAE J518 ⁵⁾ DIN 13	2 in M20 x 2.5; 30 deep	400	O
T ₁	Drain line	DIN 3852 ⁷⁾	M42 x 2; 20 deep	3	O ⁶⁾
T ₂	Drain line	DIN 3852 ⁷⁾	M42 x 2; 20 deep	3	X ⁶⁾
U	Bearing flushing	DIN 3852 ⁷⁾	M18 x 1.5; 12 deep	3	X
M _A , M _B	Measuring operating pressure	DIN 3852 ⁷⁾	M14 x 1.5; 12 deep	400	X

- 1) To shaft collar
- 2) Center bore according to DIN 332 (thread according to DIN 13)
- 3) Observe the general instructions on page 46 for the maximum tightening torques.
- 4) Momentary pressure spikes may occur depending on the application. Keep this in mind when selecting measuring devices and fittings.
- 5) Only dimensions according to SAE J518, metric fastening thread is a deviation from standard.
- 6) Depending on installation position, T₁ or T₂ must be connected (see also installation instructions on page 44).
- 7) The spot face can be deeper than specified in the appropriate standard.
- 8) O = Must be connected (plugged on delivery)
X = Plugged (in normal operation)

Dimensions size 1000

Before finalizing your design, request a binding installation drawing. Dimensions in mm.

Port plate 01 – SAE flange ports at rear

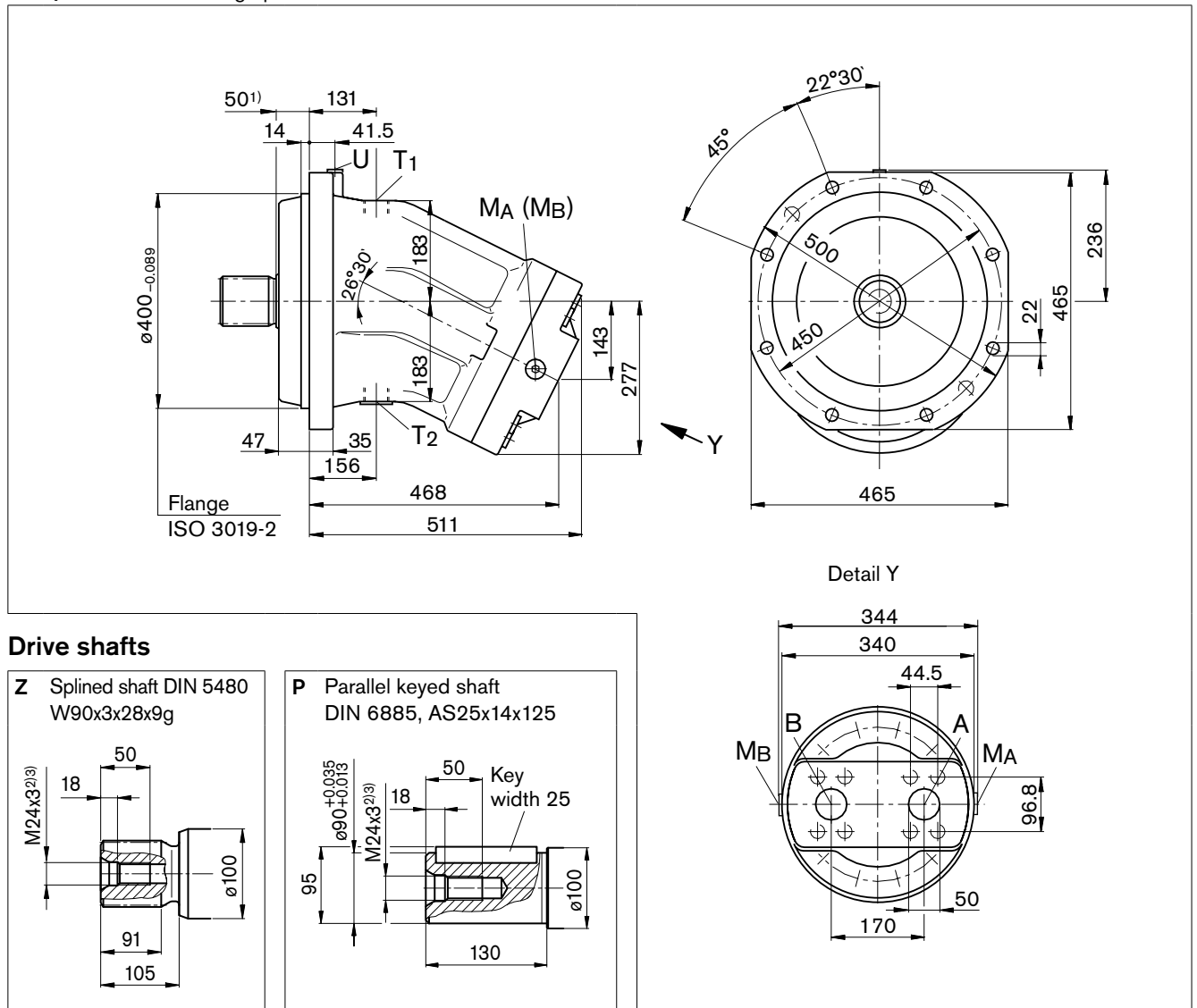

Ports

Designation	Port for	Standard	Size ⁽³⁾	Maximum pressure [bar] ⁽⁴⁾	State ⁽⁸⁾
A, B	Service line Fastening thread A/B	SAE J518 ⁽⁵⁾ DIN 13	2 in M20 x 2.5; 30 deep	400	O
T ₁	Drain line	DIN 3852 ⁽⁷⁾	M42 x 2; 20 deep	3	O ⁽⁶⁾
T ₂	Drain line	DIN 3852 ⁽⁷⁾	M42 x 2; 20 deep	3	X ⁽⁶⁾
U	Bearing flushing	DIN 3852 ⁽⁷⁾	M18 x 1.5; 12 deep	3	X
M _A , M _B	Measuring operating pressure	DIN 3852 ⁽⁷⁾	M14 x 1.5; 12 deep	400	X

1) To shaft collar

2) Center bore according to DIN 332 (thread according to DIN 13)

3) Observe the general instructions on page 46 for the maximum tightening torques.

4) Momentary pressure spikes may occur depending on the application. Keep this in mind when selecting measuring devices and fittings.

5) Only dimensions according to SAE J518, metric fastening thread is a deviation from standard.

6) Depending on installation position, T₁ or T₂ must be connected (see also installation instructions on page 44).

7) The spot face can be deeper than specified in the appropriate standard.

8) O = Must be connected (plugged on delivery)

X = Plugged (in normal operation)

Flushing and boost pressure valve

Before finalizing your design, request a binding installation drawing. Dimensions in mm.

The flushing and boost pressure valve is used to remove heat from the hydraulic circuit.

In an open circuit, it is used only for flushing the housing.

In a closed circuit, it ensures a minimum boost pressure level in addition to the case flushing.

Hydraulic fluid is directed from the respective low pressure side into the motor housing. This is then fed into the reservoir, together with the case drain fluid. The hydraulic fluid, removed out of the closed circuit must be replaced by cooled hydraulic fluid from the boost pump.

With port plate 027, the valve is mounted directly on the fixed motor (sizes 45 to 180, 250); with port plate 017 (sizes 355 and 500) on a plate.

Cracking pressure of pressure retaining valve

(observe when setting the primary valve)

Sizes 45 to 500, fixed setting _____ 16 bar

Switching pressure of flushing piston Δp

Sizes 45 to 500 _____ 8 ± 1 bar

Flushing flow q_v

Orifice (throttles with integrated valve) can be used to set the flushing flows as required.

Following parameters are based on:

$$\Delta p_{ND} = p_{ND} - p_G = 25 \text{ bar and } v = 10 \text{ mm}^2/\text{s}$$

(p_{ND} = low pressure, p_G = case pressure)

Schematic

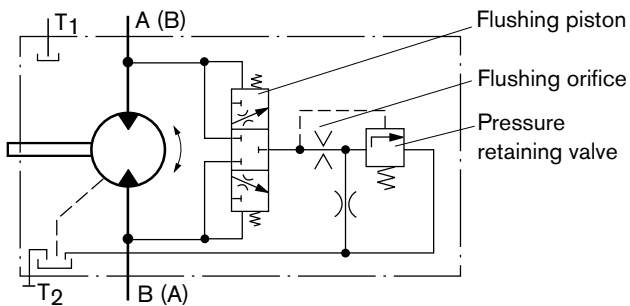

Standard flushing flows

Flushing and boost pressure valve, mounted (code 7)

Size	Flushing flow q_v [L/min]	ϕ [mm]	Mat. No. of orifice
45	3.5	1.2	R909651766
107, 125	8	1.8	R909419696
160, 180	10	2.0	R909419697
250	10	2.0	R909419697
355, 500	16	2.5	R910803019

With sizes 45 to 180, orifices can be supplied for flushing flows from 3.5 to 10 L/min. For other flushing flows, please state the required flushing flow when ordering. The flushing flow without orifice is approx. 12 to 14 L at low pressure $\Delta p_{ND} = 25$ bar.

Flushing and boost pressure valve, integrated (code 9)

Size	Throttle ϕ [mm]	q_v [L/min]
56, 63, 80, 90	1.5	6
	1.8	7.3

Flushing and boost pressure valve

Before finalizing your design, request a binding installation drawing. Dimensions in mm.

Dimensions

Port plate 027 – SAE flange ports at side

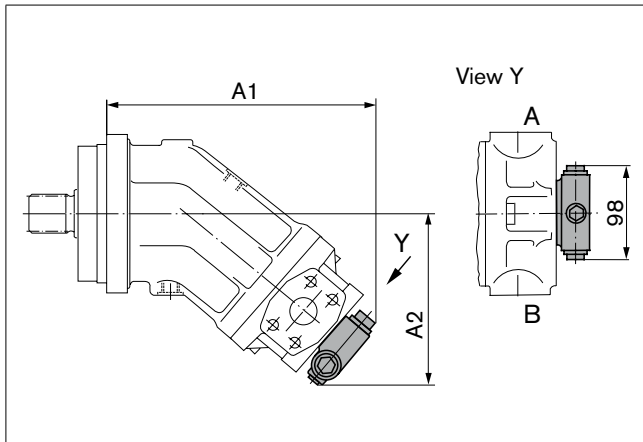

Size	A1	A2
45	223	151
107, 125	294	192
160, 180	315	201
250	344	172

Port plate 017 – SAE flange ports at rear

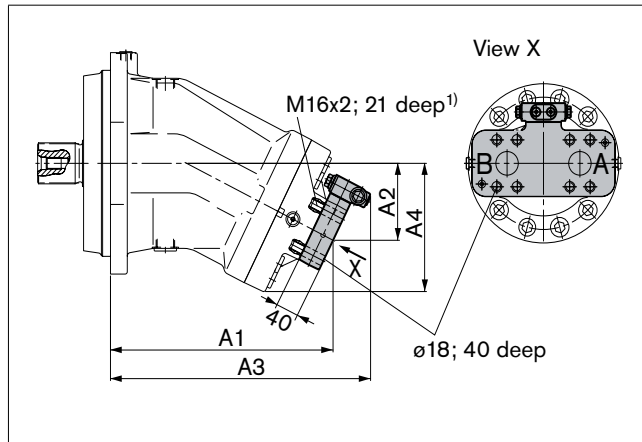

Size	A1	A2	A3	A4
355	356	120	421	198
500	397	130	464	220

1) DIN 13, observe the general instructions on page 46 for the maximum tightening torques

Port plate 029 – SAE flange ports at side

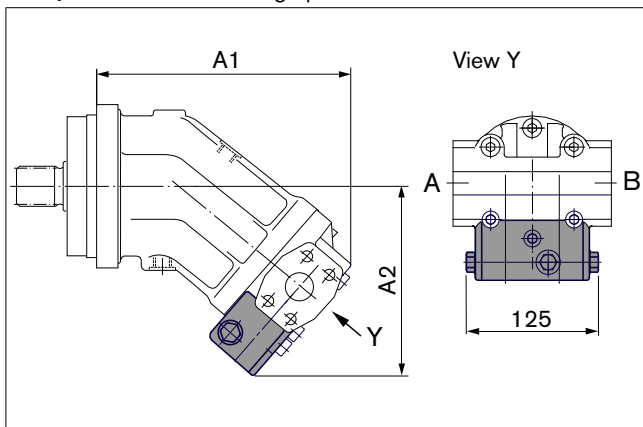

Size	A1	A2
56, 63	225	176
80, 90	257	186.7

Pressure-relief valve

The MHDB pressure-relief valves (see RE 64642) protect the hydraulic motor from overload. As soon as the set cracking pressure is reached, the hydraulic fluid flows from the high-pressure side to the low-pressure side.

The pressure-relief valves are only available in combination with port plates 181, 191 or 192 (counterbalance valve for mounting to port plate 181: see next page).

Cracking pressure setting range _____ 50 to 420 bar

With the version "with pressure boost facility" (192), a higher pressure setting can be realized by applying an external pilot pressure of 25 to 30 bar to port P_{St} .

When ordering, please state in plain text:

- Cracking pressure of pressure-relief valve
- Cracking pressure with pilot pressure applied to P_{St} (only with version 192)

Before finalizing your design, request a binding installation drawing. Dimensions in mm.

Version without pressure boost facility "191"

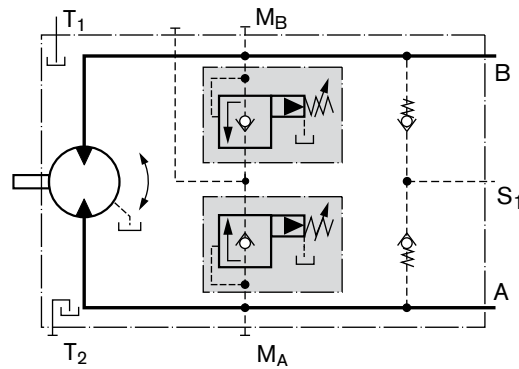

Version with pressure boost facility "192"

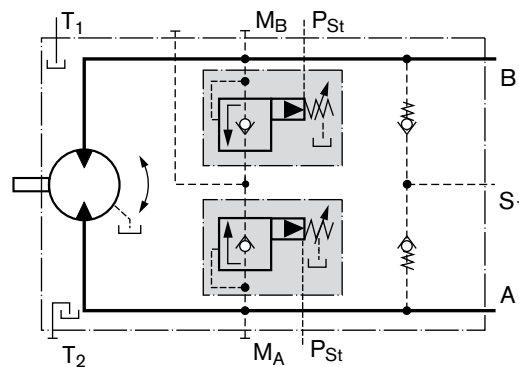

Pressure-relief valve

Before finalizing your design, request a binding installation drawing. Dimensions in mm.

Dimensions

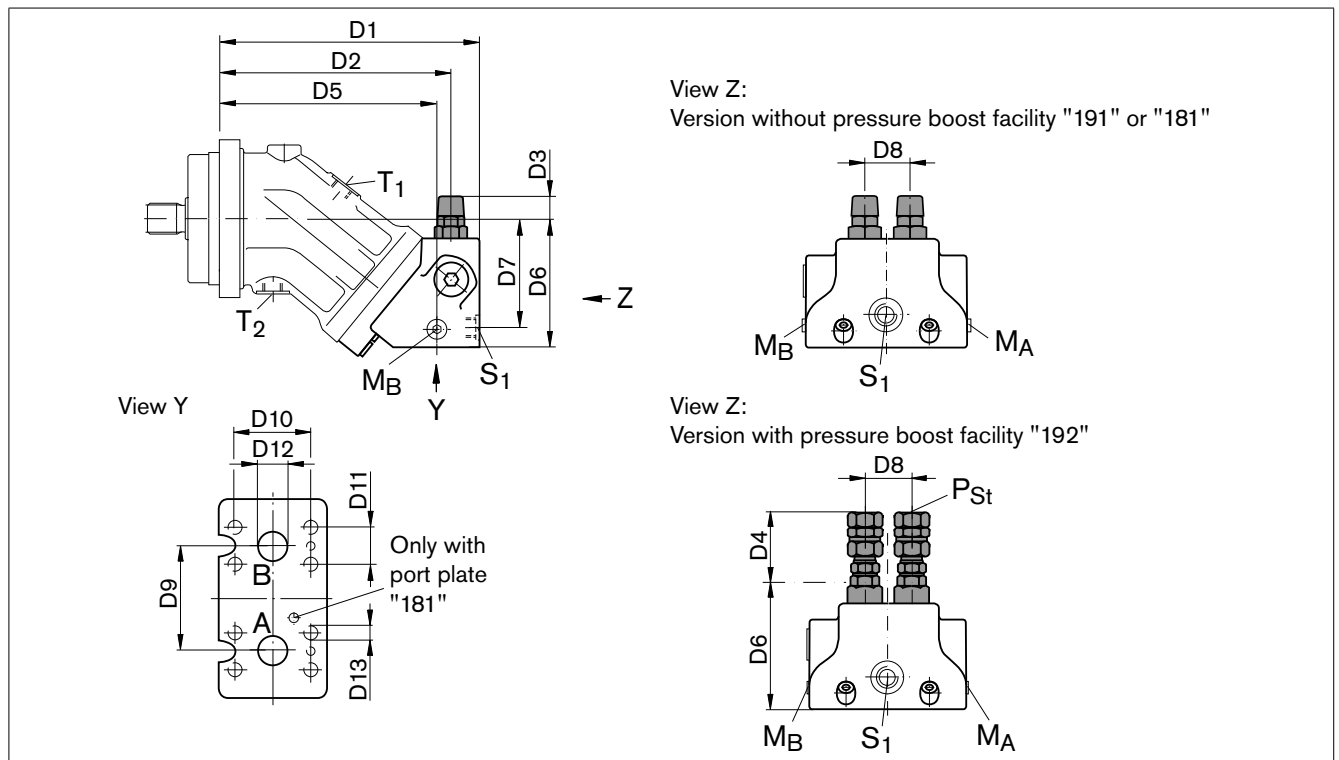

Size		D1	D2	D3	D4	D5	D6	D7	D8	D9	D10	D11	D12	D13 ²⁾
28, 32	MHDB.16	209	186	25	68	174	102	87	36	66	50.8	23.8	ø19	M10; 17 deep
45	MHDB.16	222	198	22	65	187	113	98	36	66	50.8	23.8	ø19	M10; 17 deep
56, 63	MHDB.22	250	222	19	61	208	124	105	42	75	50.8	23.8	ø19	M10; 13 deep
80, 90	MHDB.22	271	243	17.5	59	229	134	114	42	75	57.2	27.8	ø25	M12; 18 deep
107, 125	MHDB.32	298	266	10	52	250	149.5	130	53	84	66.7	31.8	ø32	M14; 19 deep
160, 180	MHDB.32	332	301	5	47	285	170	149	53	84	66.7	31.8	ø32	M14; 19 deep

Size	A, B	S ₁ ¹⁾	M _A , M _B ¹⁾	P _{St} ¹⁾
28, 32	3/4 in	M22 x 1.5; 14 deep	M20 x 1.5; 14 deep	G 1/4
45	3/4 in	M22 x 1.5; 14 deep	M20 x 1.5; 14 deep	G 1/4
56, 63	3/4 in	M26 x 1.5; 16 deep	M26 x 1.5; 16 deep	G 1/4
80, 90	1 in	M26 x 1.5; 16 deep	M26 x 1.5; 16 deep	G 1/4
107, 125	1 1/4 in	M26 x 1.5; 16 deep	M26 x 1.5; 16 deep	G 1/4
160, 180	1 1/4 in	M26 x 1.5; 16 deep	M30 x 1.5; 16 deep	G 1/4

Assembly instructions for port plate with pressure boost facility "192":

The lock nut must be counterheld when installing the hydraulic line at the p_{st} port!

Ports

Designation	Port for	Standard	Size	Maximum pressure [bar] ²⁾	State ³⁾
A, B	Service line	SAE J518	See above	450	O
S ₁	Supply (only with port plate 191/192)	DIN 3852	See above	5	O
M _A , M _B	Measuring operating pressure	DIN 3852	See above	450	X
P _{St}	Pilot pressure (only with port plate 192)	DIN ISO 228	See above	30	O

1) Observe the general instructions on page 46 for the maximum tightening torques.

2) Momentary pressure spikes may occur depending on the application. Keep this in mind when selecting measuring devices and fittings.

3) O = Must be connected (plugged on delivery)

X = Plugged (in normal operation)

Counterbalance valve BVD and BVE

Before finalizing your design, request a binding installation drawing. Dimensions in mm.

Function

Travel drive/winch counterbalance valves are designed to reduce the danger of overspeeding and cavitation of axial piston motors in open circuits. Cavitation occurs if the motor speed is greater than it should be for the given input flow while braking, travelling downhill, or lowering a load.

If the inlet pressure drops, the counterbalance spool throttles the return flow and brakes the motor until the inlet pressure returns to approx. 20 bar.

Note

- BVD available for sizes 28 to 180 and BVE available for sizes 107 to 180.
- The counterbalance valve must be ordered additionally. We recommend ordering the counterbalance valve and the motor as a set. Ordering example: A2FM90/61W-VAB188 + BVD20F27S/41B-V03K16D0400S12
- The counterbalance valve does not replace the mechanical service brake and park brake.
- Observe the detailed notes on the BVD counterbalance valve in RE 95522 and BVE counterbalance valve in RE 95525!
- For the design of the brake release valve, we must know for the mechanical park brake:
 - the pressure at the start of opening
 - the volume of the counterbalance spool between minimum stroke (brake closed) and maximum stroke (brake released with 21 bar)
 - the required closing time for a warm device (oil viscosity approx. 15 mm²/s)

Travel drive counterbalance valve BVD...F

Application option

- Travel drive on wheeled excavators

Example schematic for travel drive on wheeled excavators A2FM090/61W-VAB188 + BVD20F27S/41B-V03K16D0400S12

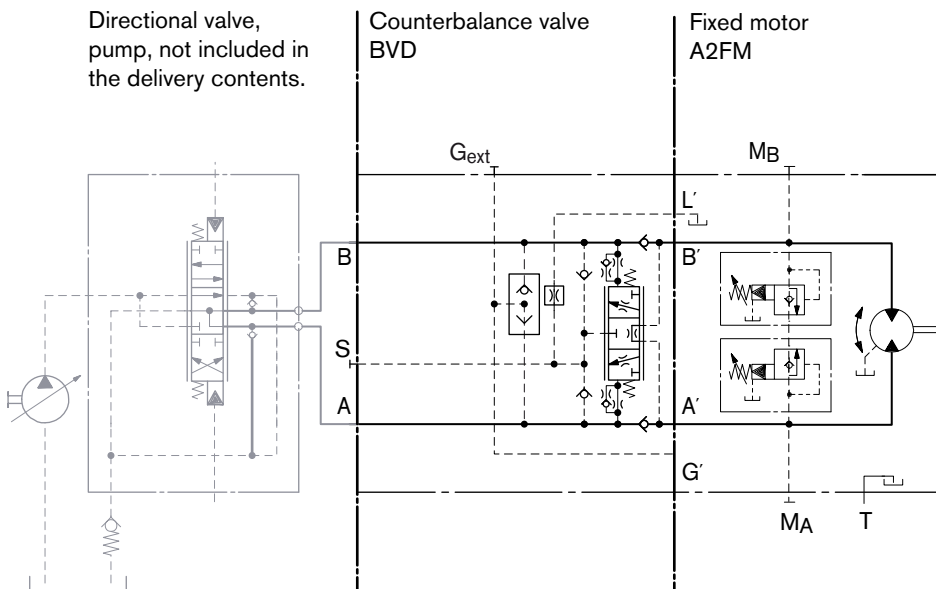

Counterbalance valve BVD and BVE

Before finalizing your design, request a binding installation drawing. Dimensions in mm.

Winch counterbalance valve BVD...W and BVE

Application options

- Winch drive in cranes (BVD and BVE)
- Track drive in excavator crawlers (BVD)

Example schematic for winch drive in cranes

A2FM090/61W-VAB188 + BVE25W385/51 ND-V100K00D4599T30S00-0

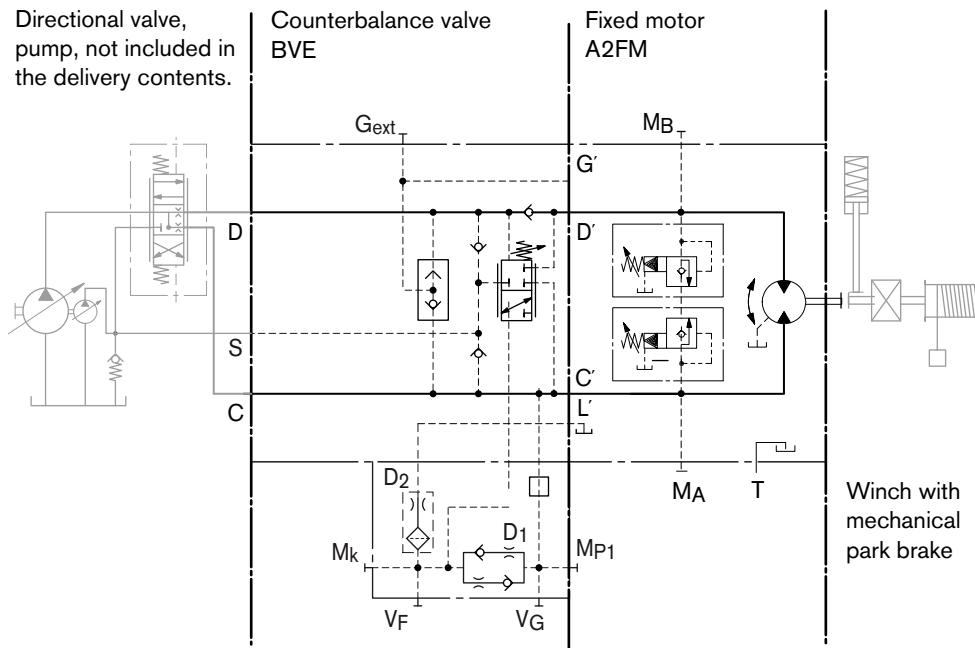

Permissible input flow or pressure in operation with DBV and BVD/BVE

Motor NG	Without valve		Restricted values in operation with DBV and BVD/BVE										
	P_{nom}/P_{max} [bar]	$q_v \text{ max}$ [L/min]	DBV NG	P_{nom}/P_{max} [bar]	q_v [L/min]	Code	BVD/BVE NG	P_{nom}/P_{max} [bar]	q_v [L/min]	Code			
28	400/450	176	16	350/420	100	181 191, 192	20 (BVD)	350/420	100	188			
32		201											
45		255											
56		280									22	240	220
63		315											
80		360											
90		405	32		400	171 191, 192	25 (BVD/BVE)		320	188			
107		427											
125		500											
107		427											
125		500											
160		577											
180	648												

DBV _____ pressure-relief valve

BVD _____ counterbalance valve, double-acting

BVE _____ counterbalance valve, one-sided

Counterbalance valve BVD and BVE

Before finalizing your design, request a binding installation drawing. Dimensions in mm.

Dimensions

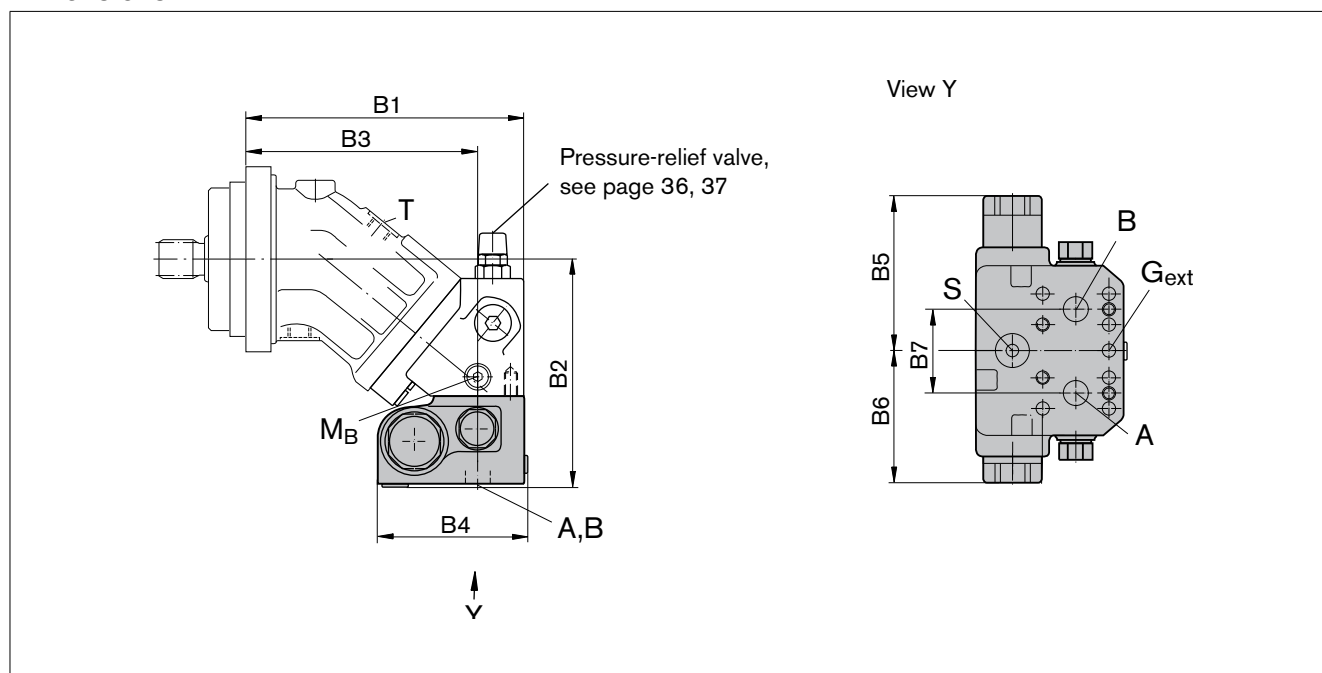

A2FM Size	Counterbalance valve			Dimensions							
	Type	Ports A, B		B1	B2	B3	B4 (S)	B4 (L)	B5	B6	B7
28, 32	BVD20..16	3/4 in		209	175	174	142	147	139	98	66
45	BVD20..16	3/4 in		222	196	187	142	147	139	98	66
56, 63	BVD20..17	3/4 in		250	197	208	142	147	139	98	75
80, 90	BVD20..27	1 in		271	207	229	142	147	139	98	75
107, 125	BVD20..28	1 in		298	238	251	142	147	139	98	84
107, 125	BVD25..38	1 1/4 in		298	239	251	158	163	175	120.5	84
160, 180	BVD25..38	1 1/4 in		332	260	285	158	163	175	120.5	84
107, 125	BVE25..38	1 1/4 in		298	240	251	167	172	214	137	84
160, 180	BVE25..38	1 1/4 in		332	260	285	167	172	214	137	84
250	On request										

Ports

Designation	Port for	Version	Standard	Size ¹⁾	Maximum pressure [bar] ²⁾	State ⁴⁾
A, B	Service line		SAE J518	see table above	420	O
S	Infeed	BVD20	DIN 3852 ³⁾	M22 x 1.5; 14 deep	30	X
		BVD25, BVE25	DIN 3852 ³⁾	M27 x 2; 16 deep	30	X
Br	Brake release, reduced high pressure	L	DIN 3852 ³⁾	M12 x 1.5; 12.5 deep	30	O
G _{ext}	Brake release, high pressure	S	DIN 3852 ³⁾	M12 x 1.5; 12.5 deep	420	X
M _A , M _B	Measuring pressure A and B		ISO 6149 ³⁾	M12 x 1.5; 12 deep	420	X

1) Observe the general instructions on page 46 for the maximum tightening torques.

2) Momentary pressure spikes may occur depending on the application. Keep this in mind when selecting measuring devices and fittings.

3) The spot face can be deeper than specified in the appropriate standard.

4) O = Must be connected (plugged on delivery)

X = Plugged (in normal operation)

Counterbalance valve BVD and BVE

Before finalizing your design, request a binding installation drawing. Dimensions in mm.

Mounting the counterbalance valve

When delivered, the counterbalance valve is mounted to the motor with two tacking screws (transport protection). The tacking screws may not be removed while mounting the service lines. If the counterbalance valve and motor are delivered separately, the counterbalance valve must first be mounted to the motor port plate using the provided tacking screws. The counterbalance valve is finally mounted to the motor by screwing on the SAE flange with the following screws:

6 screws (1, 2, 3, 4, 5, 8) _____ length $B1+B2+B3$
2 screws (6, 7) _____ length $B3+B4$

Tighten the screws in two steps in the specified sequence from 1 to 8 (see following scheme).

In the first step, the screws must be tightened with half the tightening torque, and in the second step with the maximum tightening torque (see following table).

Thread	Strength class	Tightening torque [Nm]
M6 x 1 (tacking screw)	10.9	15.5
M10	10.9	75
M12	10.9	130
M14	10.9	205

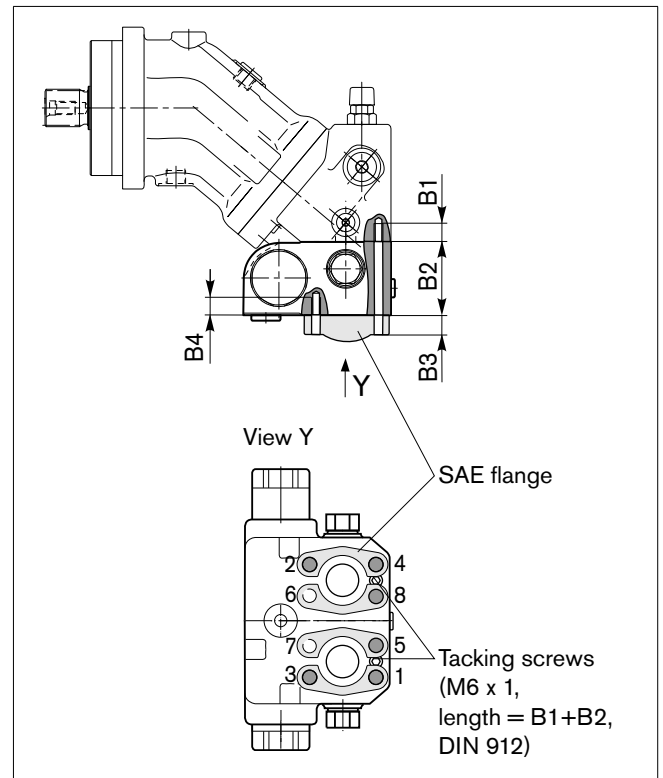

Size	28, 32, 45	56, 63	80, 90	107, 125, 160, 180	107, 125
Port plate	18				17
B1 ¹⁾	M10 x 1.5; 17 deep	M10 x 1.5; 17 deep	M12 x 1.75; 18 deep	M14 x 2; 19 deep	M12 x 1.75; 17 deep
B2	78 ²⁾	68	68	85	68
B3	customer-specific				
B4	M10 x 1.5; 15 deep	M10 x 1.5; 15 deep	M12 x 1.75; 16 deep	M14 x 2; 19 deep	M12 x 1.75; 17 deep

1) Minimum required thread reach $1 \times \varnothing$ -thread

2) Including sandwich plate

Speed sensors

The versions A2FM...U and A2FM...F ("prepared for speed sensor", i.e. without sensor) is equipped with a toothed ring on the rotary group.

On deliveries "prepared for speed sensor", the port is plugged with a pressure-resistant cover.

With the DSA or HDD speed sensor mounted a signal proportional to motor speed can be generated.

The sensors measures the speed and direction of rotation.

Ordering code, technical data, dimensions and details on the connector, plus safety information about the sensor can be found in the relevant data sheet.

DSA _____ RE 95133

HDD _____ RE 35135

The sensor is mounted at the specially provided port D as follows:

DSA _____ with one mounting bolt

HDD _____ with two mounting bolts

We recommend ordering the A2FM fixed motor complete with sensor mounted.

Version "V"

Sizes 23 to 200 with DSA sensor

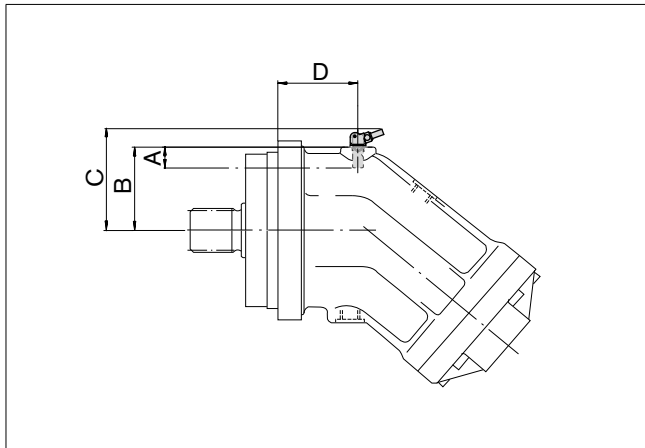

Version "V"

Sizes 250 to 500 with DSA sensor

On request

Before finalizing your design, request a binding installation drawing. Dimensions in mm.

Version "H"

Sizes 250 to 500 with HDD sensor

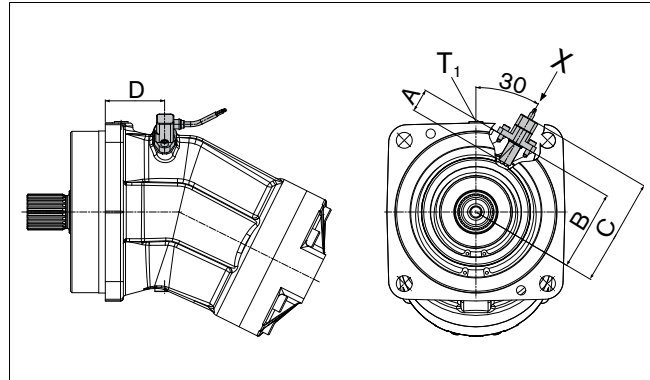

View X

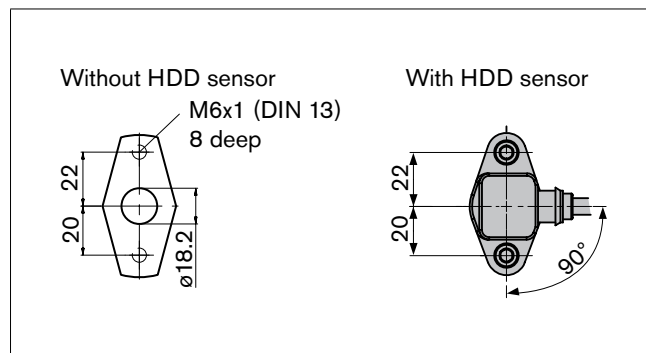

Speed sensors

Before finalizing your design, request a binding installation drawing. Dimensions in mm.

Size			23, 28, 32	45	56, 63	80, 90	107, 125
Number of teeth			38	45	47	53	59
DSA	A	Insertion depth (tolerance ± 0.1)	18.4	18.4	18.4	18.4	18.4
	B	Contact surface	57.9	64.9	69.9	74.9	79.9
	C		74.5	81.5	86.5	91.5	96.5
	D		54.7	54.3	61.5	72.5	76.8
Size			160, 180	200	250	355	500
Number of teeth			67	80	78	90	99
HDD	A	Insertion depth (tolerance ± 0.1)	–	–	32	32	32
	B	Contact surface	–	–	110.5	122.5	132.5
	C		–	–	149	161	171
	D		–	–	82	93	113
DSA	A	Insertion depth (tolerance ± 0.1)	18.4	18.4	32	32	32
	B	Contact surface	87.4	100.9	–	–	–
	C		104	117.5	–	–	–
	D		86.8	97.5			

Installation instructions

General

During commissioning and operation, the axial piston unit must be filled with hydraulic fluid and air bled. This must also be observed following a relatively long standstill as the axial piston unit may drain back to the reservoir via the hydraulic lines.

Particularly in the installation position "drive shaft upwards" filling and air bleeding must be carried out completely as there is, for example, a danger of dry running.

The case drain fluid in the motor housing must be directed to the reservoir via the highest available drain port (T_1 , T_2).

For combinations of multiple units, make sure that the respective case pressure in each unit is not exceeded. In the event of pressure differences at the drain ports of the units, the shared drain line must be changed so that the minimum permissible case pressure of all connected units is not exceeded in any situation. If this is not possible, separate drain lines must be laid if necessary.

To achieve favorable noise values, decouple all connecting lines using elastic elements and avoid above-reservoir installation.

In all operating conditions, the drain line must flow into the reservoir below the minimum fluid level.

Installation position

See the following examples 1 to 8.

Further installation positions are possible upon request.

Recommended installation positions: 1 and 2.

Note

With sizes 10 to 200 with installation position "shaft upward", an air-bleed port R is required (state in plain text when ordering - special version). With sizes 250 to 1000, port U is provided as standard in the area near the bearings for air bleeding.

Installation position	Air bleed	Filling
1	-	T_1
2	-	T_2
3	-	T_1
4	R (U)	T_2
5	L_1	T_1 (L_1)
6	L_1	T_2 (L_1)
7	L_1	T_1 (L_1)
8	R (U)	T_2 (L_1)

L_1	Filling / air bleed
R	Air bleed port (special version)
U	Bearing flushing / air bleed port
T_1 , T_2	Drain port
$h_{t \text{ min}}$	Minimum required immersion depth (200 mm)
h_{min}	Minimum required spacing to reservoir bottom (100 mm)

Below-reservoir installation (standard)

Below-reservoir installation means that the axial piston unit is installed outside of the reservoir below the minimum fluid level.

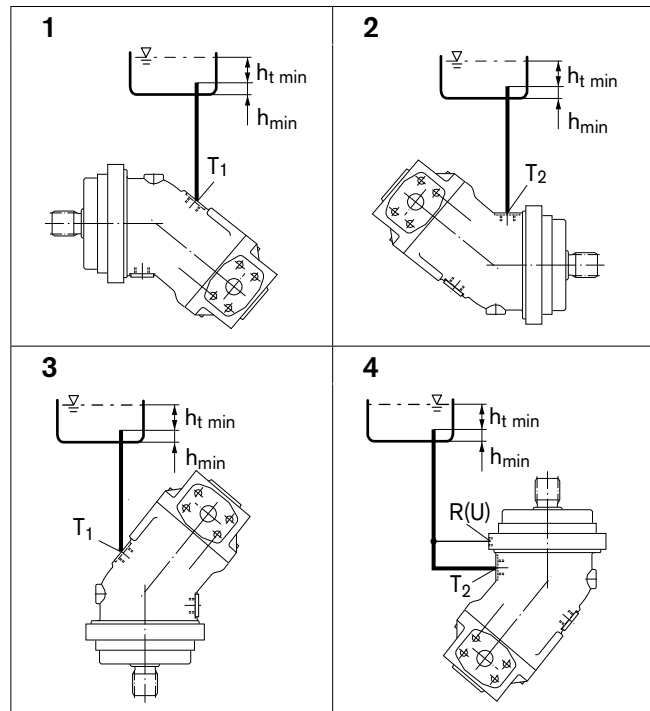

Above-reservoir installation

Above-reservoir installation means that the axial piston unit is installed above the minimum fluid level of the reservoir.

Recommendation for installation position 8 (drive shaft upward): A check valve in the drain line (cracking pressure 0.5 bar) can prevent draining of the motor housing.

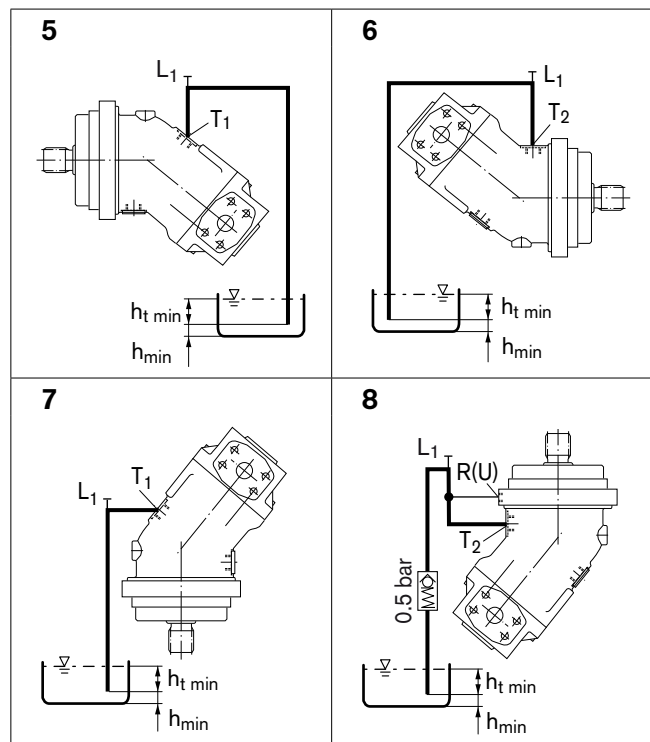

General instructions

- The motor A2FM is designed to be used in open and closed circuits.
- The project planning, installation and commissioning of the axial piston unit requires the involvement of qualified personnel.
- Before using the axial piston unit, please read the corresponding instruction manual completely and thoroughly. If necessary, these can be requested from Bosch Rexroth.
- During and shortly after operation, there is a risk of burns on the axial piston unit. Take appropriate safety measures (e. g. by wearing protective clothing).
- Depending on the operating conditions of the axial piston unit (operating pressure, fluid temperature), the characteristic may shift.
- Service line ports:
 - The ports and fastening threads are designed for the specified maximum pressure. The machine or system manufacturer must ensure that the connecting elements and lines correspond to the specified application conditions (pressure, flow, hydraulic fluid, temperature) with the necessary safety factors.
 - The service line ports and function ports can only be used to accommodate hydraulic lines.
- The data and notes contained herein must be adhered to.
- The product is not approved as a component for the safety concept of a general machine according to ISO 13849.
- The following tightening torques apply:
 - Fittings:
 - Observe the manufacturer's instructions regarding tightening torques of the fittings used.
 - Mounting bolts:
 - For mounting bolts with metric ISO thread according to DIN 13 or with thread according to ASME B1.1, we recommend checking the tightening torque in individual cases in accordance with VDI 2230.
 - Female threads in the axial piston unit:
 - The maximum permissible tightening torques $M_{G \max}$ are maximum values for the female threads and must not be exceeded. For values, see the following table.
 - Threaded plugs:
 - For the metallic threaded plugs supplied with the axial piston unit, the required tightening torques of threaded plugs M_V apply. For values, see the following table.

Ports		Maximum permissible tightening torque of the female threads $M_{G \max}$	Required tightening torque of the threaded plugs $M_V^{1)}$	WAF hexagon socket of the threaded plugs
Standard	Size of thread			
DIN 3852 ¹⁾	M10 x 1	30 Nm	15 Nm ²⁾	5 mm
	M12 x 1.5	50 Nm	25 Nm ²⁾	6 mm
	M14 x 1.5	80 Nm	35 Nm	6 mm
	M16 x 1.5	100 Nm	50 Nm	8 mm
	M18 x 1.5	140 Nm	60 Nm	8 mm
	M20 x 1.5	170 Nm	80 Nm	10 mm
	M22 x 1.5	210 Nm	80 Nm	10 mm
	M26 x 1.5	230 Nm	120 Nm	12 mm
	M27 x 2	330 Nm	135 Nm	12 mm
	M30 x 2	420 Nm	215 Nm	17 mm
	M33 x 2	540 Nm	225 Nm	17 mm
M42 x 2	720 Nm	360 Nm	22 mm	
DIN ISO 228	G 1/4	40 Nm	–	–

1) The tightening torques apply for screws in the "dry" state as received on delivery and in the "lightly oiled" state for installation.

2) In the "lightly oiled" state, the M_V is reduced to 10 Nm for M10 x 1 and 17 Nm for M12 x 1.5.

Bosch Rexroth AG
 Mobile Applications
 Glockeraustrasse 4
 89275 Elchingen, Germany
 Tel.: +49-7308-82-0
 Fax: +49-7308-72-74
 info.brm@boschrexroth.de
 www.boschrexroth.com/axial-piston-motors

An den Kelterwiesen 14
 72160 Horb, Germany
 Tel.: +49-7451-92-0
 Fax: +49-7451-82-21

© This document, as well as the data, specifications and other information set forth in it, are the exclusive property of Bosch Rexroth AG. It may not be reproduced or given to third parties without its consent.

The data specified above only serve to describe the product. No statements concerning a certain condition or suitability for a certain application can be derived from our information. The information given does not release the user from the obligation of own judgment and verification. It must be remembered that our products are subject to a natural process of wear and aging.

Subject to change.