

Parameters

Electric Parameter :	
Input power	POE , 0 - 3
Input current	400mA(MAX)
Output power	DC5V
Output current	2.1A
output terminal	USB , DC terminal
Environmental Condition :	
Working Temperature	0°C~45°C
Working relative Humidity	40%~98%
Storage Temperature	-20°C~+60°C
Storage relative Humidity	10%~93%
Approved :	
CE	
RoHS	
Production information :	
Dimensions	63×63×52 (mm)
Net Weight	1744.5g
Housing material	iron , aluminum , PC
installation	Desk
Protection	Null

Notes

- This mounting box is especial for IPAD
- Pay attention to the chamfer when installing, avoid scratch.

Parts info



Fixed frame



Bottom case



Screw



Holder



Top cover

Overview



IPAD mounting box , can fix and protect the IPAD easily, use PEO power supply mode, PEO input is compatible with IEEE 802.af standard , with functions of DC output and network signal output.

Functions

- Fix and protect IPAD
- Supply power for IPAD
- DC5V output
- Network signal output

Install step 1

As show below , keep flat the fixed frame, put the IPAD onto it .

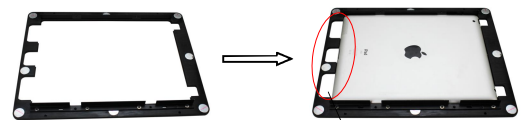

Speaker hole and power cable hole

Note, pay attention to the left-right direction of IPAD when install it.

Install step 2

Fix the holder, the screw is flat with surface, can not reveal the fixed frame. The cotton side of holder lean against the IPAD.



Install step 3

Put the fixed IPAD into the mounting box, connect the power supply, network cable etc. Can pry the wiring hole when connecting the cables.



Install step 4

Put the top cover onto the connected bottom box.



Size

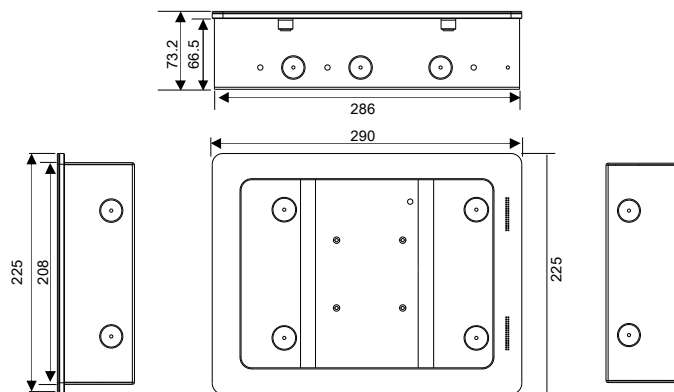

Safety attention

- Avoid the rain or water into module, it will damage this devices
- Rain, liquid, and aggressive gas are not allowed to close to it