



کنتورهای گاز دیافراگمی

کنتور گاز دیافراگمی وسیله‌ای برای اندازه‌گیری حجم گاز می‌باشد. این نوع کنتور از دو محفظه دهلیز که هر یک توسط یک پرده قابل انعطاف (دیافراگم) به دو بخش تقسیم شده است تشکیل می‌گردد.

با پر و خالی شدن متناوب محفظه‌ها در اثر عبور جریان گاز جابه‌جایی دیافراگم‌ها صورت می‌گیرد. جابه‌جایی دیافراگم توسط اهرم بندبهایی مناسب باعث گردش میل لنگ می‌شوند. این گردش که متناسب با حجم گاز عبوری از محفظه‌ها می‌باشد به وسیله سیستم انتقال حرکت مغناطیسی و با چرخ دنده‌ای به شماره انداز کنتور منتقل می‌گردد.



GAS SOUZAN





TECHNICAL DATA

Fig. 1: GS-84-2.5A Dimension

ITEM	CHARACTERISTICS	FEATURES	COMMENTS
1	Type	GS-84-02.5A	
2	G-Rating	G2.5	
3	Max-Flow Rate (Q_{max})	4 m ³ /h	
4	Min-Flow Rate (Q_{min})	0.025 m ³ /h	
5	Cyclic Volume	1.2 dm ³	
6	Max-Operating Pressure	0.5 bar	
7	Number of Digits	5 Digits + 3 Decimal	
8	Scale Division	0.2 dm ³	
9	Ambient Temperature	-29° C ~ +60° C	
10	Accuracy	+3% For $Q_{min} < Q \leq 2Q_{min}$ +2% For $2Q_{min} < Q \leq Q_{max}$	
11	Normal Inlet Pressure	18 mbar	
12	ID/OD Size	1 1/4"	
13	Connection Type	Threaded	
14	Connection Location	Top	
15	Thread Std	Iso 228/1	
16	Transmission System To Index	Magnetic Coupling	
17	Measuring Fluid	Air/Natural Gas/Non Corrosion Gas/...	
18	Casing	Steel	
19	Max Pressure Loss	2 mbar	

Fig. 3: Typical Error Curve

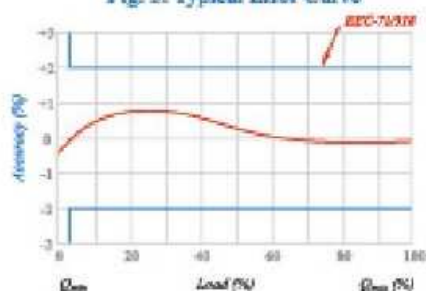
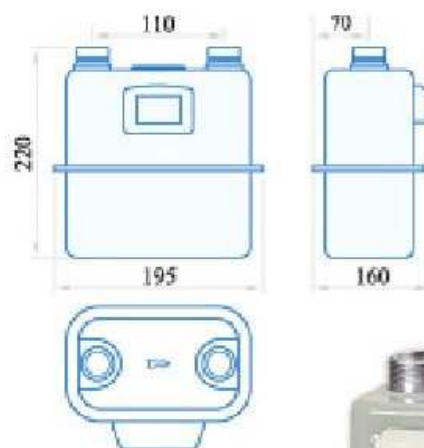
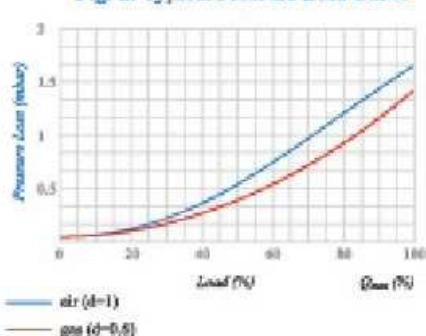

Fig. 2: Typical Pressure Loss Curve





TECHNICAL DATA

Fig. 1: GS-77-04A Dimension

ITEM	CHARACTERISTICS	FEATURES	COMMENTS
1	Type	GS-77-04A	
2	G-Rating	G4	
3	Max-Flow Rate (Q_{max})	6 m ³ /h	
4	Min-Flow Rate (Q_{min})	0.04 m ³ /h	
5	Cyclic Volume	2 dm ³	
6	Max-Operating Pressure	0.5 bar	
7	Number of Digits	5 Digits + 3 Decimal	
8	Scale Division	0.2 dm ³	
9	Ambient Temperature	-29° C ~ +60°C	
10	Accuracy	+3% For $Q_{min} < Q \leq 2Q_{min}$ +2% For $2Q_{min} < Q \leq Q_{max}$	
11	Normal Inlet Pressure	18 mbar	
12	ID/OD Size	1 1/4"	
13	Connection Type	Threaded	
14	Connection Location	Top	
15	Thread Std	Iso 228/1	
16	Transmission System To Index	Magnetic Coupling	
17	Measuring Fluid	Air/Natural Gas/Non Corrosion Gas/...	
18	Casing	Steel	
19	Max Pressure Loss	2 mbar	

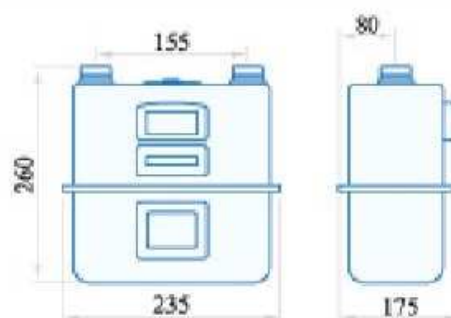
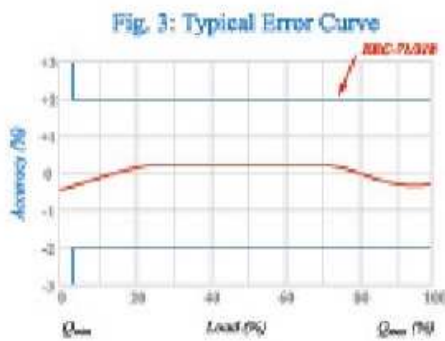

TECHNICAL DATA
Fig. 1: GS-77-04B Dimension

ITEM	CHARACTERISTICS	FEATURES	COMMENTS
1	Type	GS-77-04B	
2	G-Rating	G4	
3	Max-Flow Rate (Q_{max})	6 m ³ /h	
4	Min-Flow Rate (Q_{min})	0.04 m ³ /h	
5	Cyclic Volume	1.2 dm ³	
6	Max-Operating Pressure	0.5 bar	
7	Number of Digits	5 Digits + 3 Decimal	
8	Scale Division	0.2 dm ³	
9	Ambient Temperature	-29° C ~ +60° C	
10	Accuracy	+3% For $Q_{min} < Q < 2Q_{min}$ +2% For $2Q_{min} < Q < Q_{max}$	
11	Normal Inlet Pressure	18 mbar	
12	ID/OD Size	1 1/4"	
13	Connection Type	Threaded	
14	Connection Location	Top	
15	Thread Std	Iso 228/1	
16	Transmission System To Index	Magnetic Coupling	
17	Measuring Fluid	Air/Natural Gas/Non Corrosion Gas/...	
18	Casing	Steel	
19	Max Pressure Loss	2 mbar	

Fig. 3: Typical Error Curve

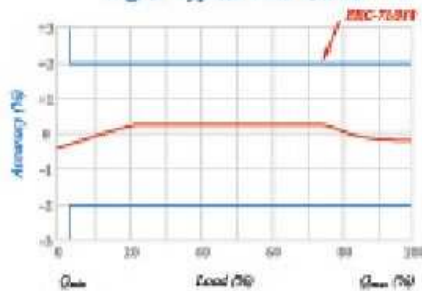
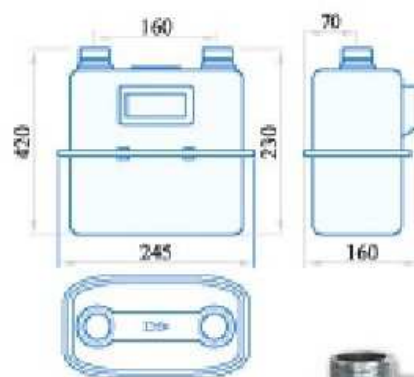
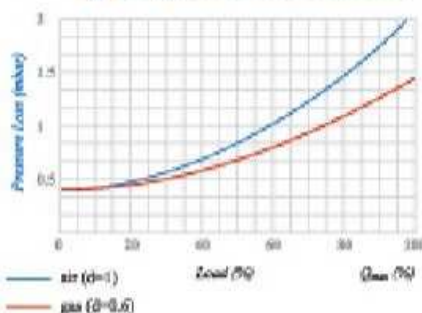

Fig. 2: Typical Pressure Loss Curve





TECHNICAL DATA

Fig. 1: GS-84-04C Dimension

ITEM	CHARACTERISTICS	FEATURES	COMMENTS
1	Type	GS-84-04C	
2	G-Rating	G4	
3	Max-Flow Rate (Q_{max})	6 m ³ /h	
4	Min-Flow Rate (Q_{min})	0.04 m ³ /h	
5	Cyclic Volume	1.2 dm ³	
6	Max-Operating Pressure	0.5 bar	
7	Number of Digits	5 Digits + 3 Decimal	
8	Scale Division	0.2 dm ³	
9	Ambient Temperature	-29° C ~ +60° C	
10	Accuracy	+3% For $Q_{min} < Q < 2Q_{min}$ +2% For $2Q_{min} < Q < Q_{max}$	
11	Normal Inlet Pressure	18 mbar	
12	ID/OD Size	1 1/4"	
13	Connection Type	Threaded	
14	Connection Location	Top	
15	Thread Std	Iso 228/1	
16	Transmission System To Index	Magnetic Coupling	
17	Measuring Fluid	Air/Natural Gas/Non Corrosion Gas/...	
18	Casing	Steel	
19	Max Pressure Loss	2 mbar	

Fig. 3: Typical Error Curve

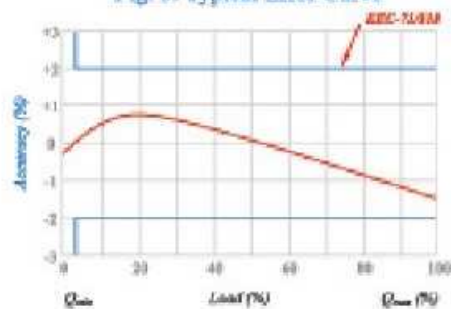
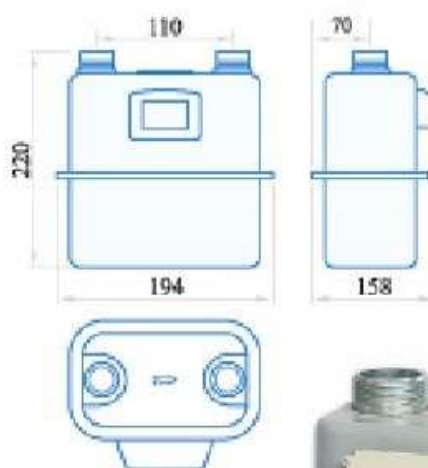
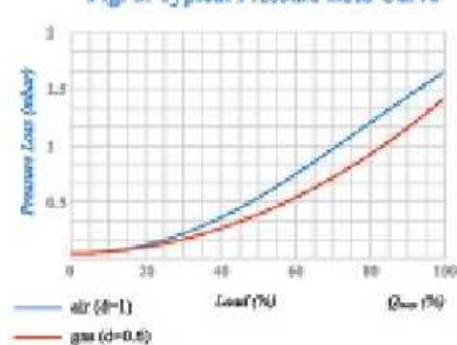

Fig. 2: Typical Pressure Loss Curve





TECHNICAL DATA

Fig. 1: GS-79-06A Dimension

ITEM	CHARACTERISTICS	MODEL	COMMENTS
1	Type	GS-79-06A	
2	G-Rating	G6	
3	Max-Flow Rate (Q_{max})	10 m ³ /h	
4	Min-Flow Rate (Q_{min})	0.06 m ³ /h	
5	Cyclic Volume	5 dm ³	
6	Max-Operating Pressure	0.5 bar	
7	Number of Digits	5 Digits + 3 Decimal	
8	Scale Division	0.2 dm ³	
9	Ambient Temperature	-29° C ~ +60° C	
10	Accuracy	±3% For $Q_{min} < Q \leq 2Q_{min}$ ±2% For $2Q_{min} < Q \leq Q_{max}$	
11	Normal Inlet Pressure	18 mbar	
12	ID/OD Size	1 ¹ / ₄ "	
13	Connection Type	Threaded	
14	Connection Location	Top	
15	Thread Std	Iso 228/1	
16	Transmission System To Index	Magnetic Coupling	
17	Measuring Fluid	Air/Natural Gas/Non Corrosion Gas/...	
18	Casing	Steel	
19	Max Pressure Loss	2 mbar	

Fig. 3: Typical Error Curve

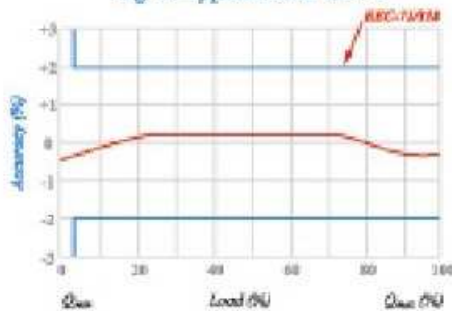
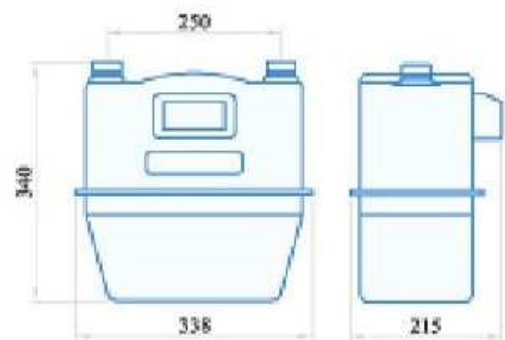
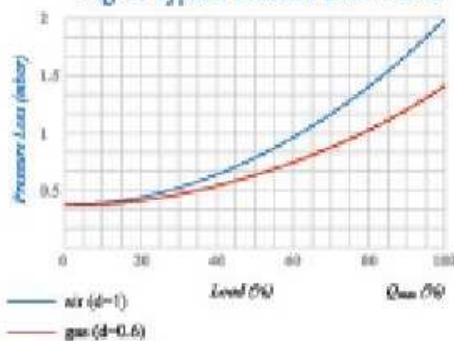

Fig. 2: Typical Pressure Loss Curve





TECHNICAL DATA

Fig. 1: GS-79-06AL Dimension

ITEM	CHARACTERISTICS	FEATURES	COMMENTS
1	Type	GS-79-06AL	
2	G-Rating	G6	
3	Max-Flow Rate (Q_{max})	10 m ³ /h	
4	Min-Flow Rate (Q_{min})	0.06 m ³ /h	
5	Cyclic Volume	5 dm ³	
6	Max-Operating Pressure	0.5 bar	
7	Number of Digits	5 Digits + 3 Decimal	
8	Scale Division	0.2 dm ³	
9	Ambient Temperature	-20° C ~ +60° C	
10	Accuracy	+3% For $Q_{min} < Q < 2Q_{min}$ +2% For $2Q_{min} < Q < Q_{max}$	
11	Normal Inlet Pressure	18 mbar	
12	ID/OD Size	1 1/4"	
13	Connection Type	Threaded	
14	Connection Location	Top	
15	Thread Std	ISO 228/1	
16	Transmission System To Index	Magnetic Coupling	
17	Measuring Fluid	Air/Natural Gas/Non Corrosion Gas/...	
18	Casing	Aluminum	
19	Pressure Loss	2 mbar	

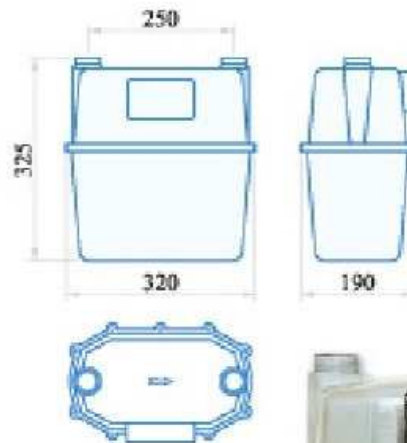
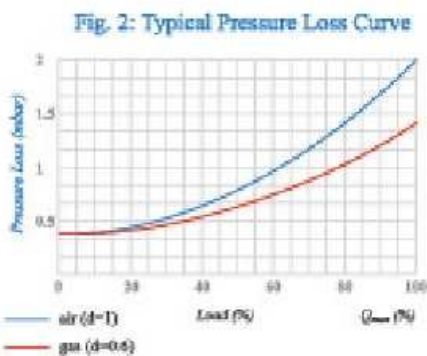
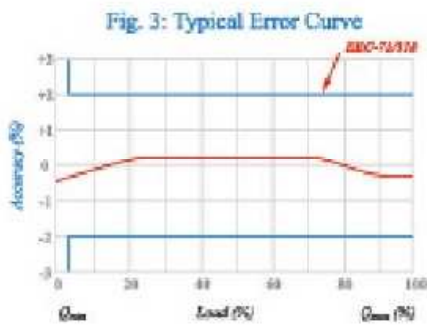



TECHNICAL DATA
Fig. 1: GS-84-06C Dimension

ITEM	CHARACTERISTICS	FEATURES	COMMENTS
1	Type	GS-84-06C	
2	G-Rating	G6	
3	Max-Flow Rate (Q_{max})	10 m ³ /h	
4	Min-Flow Rate (Q_{min})	0.06 m ³ /h	
5	Cyclic Volume	3 dm ³	
6	Max-Operating Pressure	0.5 bar	
7	Number of Digits	5 Digits + 3 Decimal	
8	Scale Division	0.2 dm ³	
9	Ambient Temperature	-29° C ~ +60° C	
10	Accuracy	+3% For $Q_{min} < Q < 2Q_{min}$ +2% For $2Q_{min} < Q < Q_{max}$	
11	Normal Inlet Pressure	18 mbar	
12	ID/OD Size	1 1/2"	
13	Connection Type	Threaded	
14	Connection Location	Top	
15	Thread Std	ISO 228/1	
16	Transmission System To Index	Magnetic Coupling	
17	Measuring Fluid	Air/Natural Gas/Non Corrosion Gas/...	
18	Casing	Steel	
19	Max Pressure Loss	2 mbar	

Fig. 3: Typical Error Curve

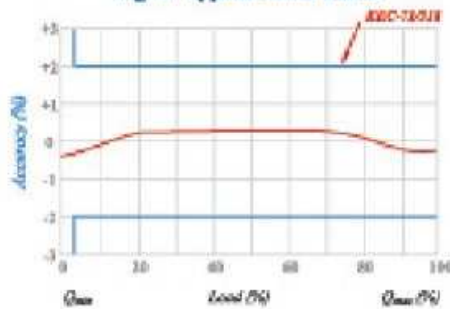
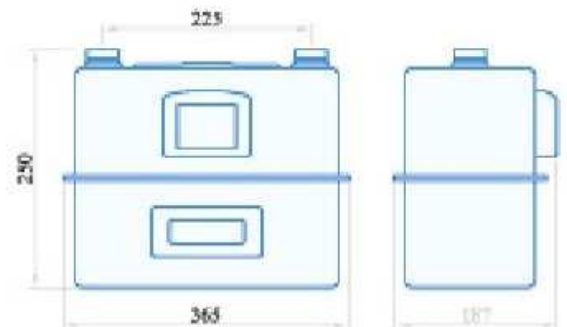
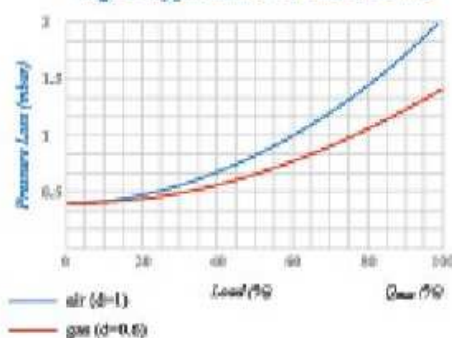

Fig. 2: Typical Pressure Loss Curve



**TECHNICAL DATA**

Fig. 1: GS-76-010A Dimension

ITEM	CHARACTERISTICS	FEATURES	COMMENTS
1	Type	GS-76-010A	
2	G-Rating	G10	
3	Max-Flow Rate (Q_{max})	16 m ³ /h	
4	Min-Flow Rate (Q_{min})	0.1 m ³ /h	
5	Cyclic Volume	10 dm ³	
6	Max-Operating Pressure	0.5 bar	
7	Number of Digits	6 Digits + 2 Decimal	
8	Scale Division	2 dm ³	
9	Ambient Temperature	-29° C ~ +60° C	
10	Accuracy	+3% For $Q_{min} < Q < 2Q_{min}$ +2% For $2Q_{min} < Q < Q_{max}$	
11	Normal Inlet Pressure	18 mbar	
12	ID/OD Size	2"	
13	Connection Type	Threaded	
14	Connection Location	Top	
15	Thread Std	ISO 228/1	
16	Transmission System To Index	Magnetic Coupling	
17	Measuring Fluid	Air/Natural Gas/Non Corrosion Gas/...	
18	Casing	Steel	
19	Max Pressure Loss	2 mbar	

Fig. 3: Typical Error Curve

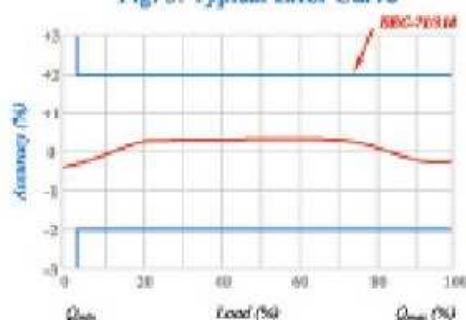
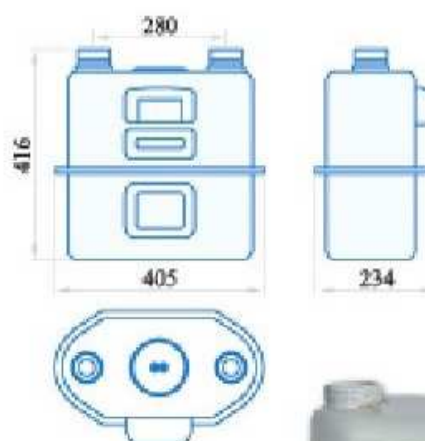
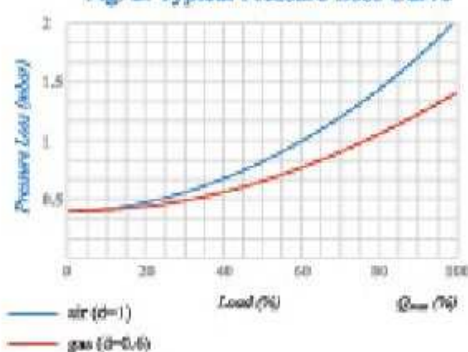

Fig. 2: Typical Pressure Loss Curve





TECHNICAL DATA

Fig. 1: GS-76-016A Dimension

ITEM	CHARACTERISTICS	FEATURES	COMMENTS
1	Type	GS-76-016A	
2	G-Rating	G16	
3	Max-Flow Rate (Q_{max})	25 m ³ /h	
4	Min-Flow Rate (Q_{min})	0.16 m ³ /h	
5	Cyclic Volume	10 dm ³	
6	Max-Operating Pressure	0.5 bar	
7	Number of Digits	6 Digits + 2 Decimal	
8	Scale Division	2 dm ³	
9	Ambient Temperature	-29° C ~ +60° C	
10	Accuracy	+3% For $Q_{min} < Q < 2Q_{min}$ +2% For $2Q_{min} < Q < Q_{max}$	
11	Normal Inlet Pressure	18 mbar	
12	ID/OD Size	2"	
13	Connection Type	Threaded	
14	Connection Location	Top	
15	Thread Std	Iso 228/1	
16	Transmission System To Index	Magnetic Coupling	
17	Measuring Fluid	Air/Natural Gas/Non Corrosion Gas/...	
18	Casing	Steel	
19	Max Pressure Loss	3 mbar	

Fig. 3: Typical Error Curve

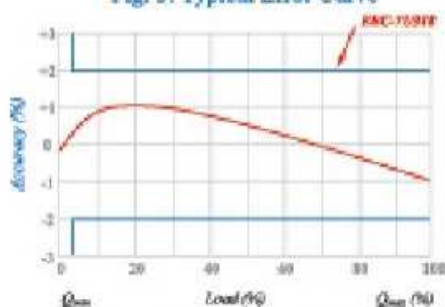
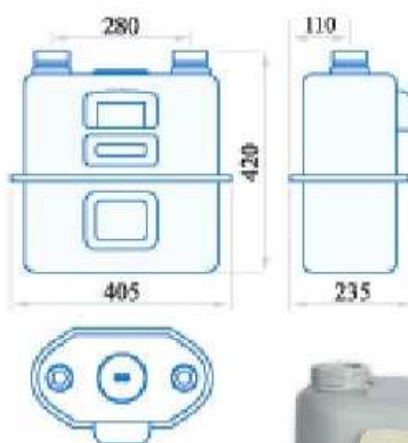
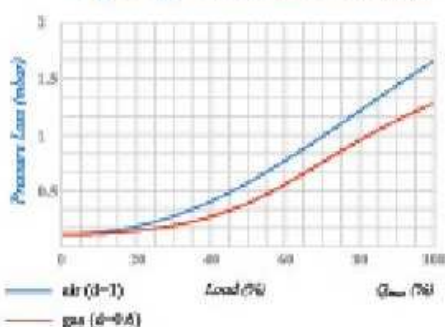

Fig. 2: Typical Pressure Loss Curve





TECHNICAL DATA

Fig. 1: GS-77-025A Dimension

ITEM	CHARACTERISTICS	FEATURES	COMMENTS
1	Type	GS-77-025A	
2	G-Rating	G25	
3	Max-Flow Rate (Q_{max})	40 m ³ /h	
4	Min-Flow Rate (Q_{min})	0.25 m ³ /h	
5	Cyclic Volume	30 dm ³	
6	Max-Operating Pressure	0.5 bar	
7	Number of Digits	6 Digits + 2 Decimal	
8	Scale Division	2 dm ³	
9	Ambient Temperature	-29° C ~ +60° C	
10	Accuracy	+3% For $Q_{min} < Q < 2Q_{min}$ +2% For $2Q_{min} < Q < Q_{max}$	
11	Normal Inlet Pressure	18 mbar	
12	ID/OD Size	2"	
13	Connection Type	Female Threaded	
14	Connection Location	Side	
15	Transmission System To Index	Magnetic Coupling	
16	Measuring Fluid	Air/Natural Gas/Non Corrosion Gas/...	
17	Casing	Steel	
18	Max Pressure Loss	3 mbar	

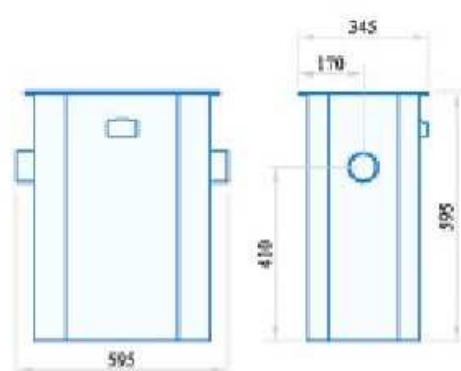

Fig. 3: Typical Error Curve

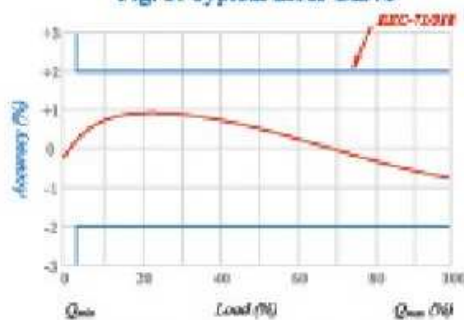
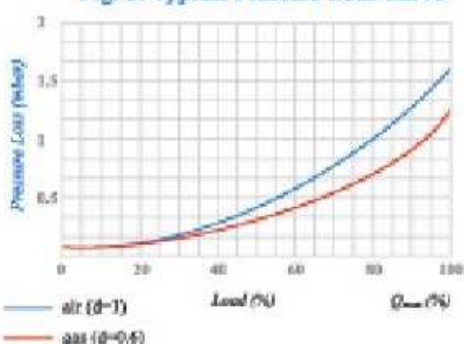

Fig. 2: Typical Pressure Loss Curve





TECHNICAL DATA

Fig. 1: GS-80-025B Dimension

ITEM	CHARACTERISTICS	FEATURES	COMMENTS
1	Type	GS-80-025B	
2	G-Rating	G25	
3	Max-Flow Rate (Q_{max})	40 m ³ /h	
4	Min-Flow Rate (Q_{min})	0.25 m ³ /h	
5	Cyclic Volume	20 dm ³	
6	Max-Operating Pressure	0.5 bar	
7	Number of Digits	6 Digits + 2 Decimal	
8	Scale Division	2 dm ³	
9	Ambient Temperature	-29° C ~ +60° C	
10	Accuracy	+3% For $Q_{min} < Q \leq 2Q_{min}$ +2% For $2Q_{min} < Q \leq Q_{max}$	
11	Normal Inlet Pressure	18 mbar	
12	ID/OD Size	2 1/2"	
13	Connection Type	Threaded	
14	Connection Location	Top	
15	Thread Std	Iso 228/1	
16	Transmission System To Index	Magnetic Coupling	
17	Measuring Fluid	Air/Natural Gas/Non Corrosion Gas/...	
18	Casing	Steel	
19	Max Pressure Loss	3 mbar	

Fig. 3: Typical Error Curve

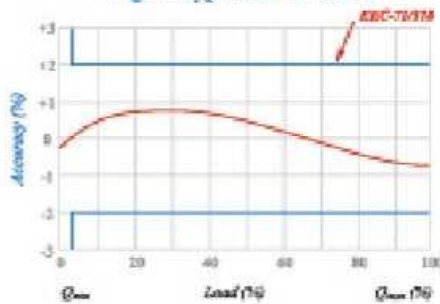
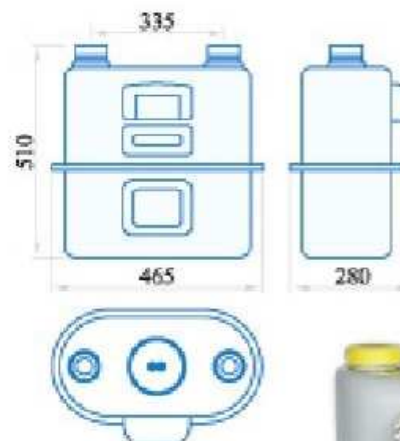
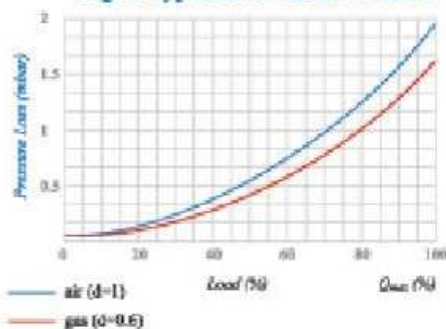

Fig. 2: Typical Pressure Loss Curve





TECHNICAL DATA

Fig. 1: GS-77-040A Dimension

ITEM	CHARACTERISTICS	FEATURES	COMMENTS
1	Type	GS-77-040A	
2	G-Rating	G40	
3	Max-Flow Rate (Q_{max})	65 m ³ /h	
4	Min-Flow Rate (Q_{min})	0.4 m ³ /h	
5	Cyclic Volume	30 dm ³	
6	Max-Operating Pressure	0.5 bar	
7	Number of Digits	6 Digits + 2 Decimal	
8	Scale Division	2 dm ³	
9	Ambient Temperature	-29° C ~ +60°C	
10	Accuracy	+3% For $Q_{min} < Q < 2Q_{min}$ +2% For $2Q_{min} < Q < Q_{max}$	
11	Normal Inlet Pressure	18 mbar	
12	ID/OD Size	3"	
13	Connection Type	Flange	
14	Connection Location	Side	
15	Flange Std	Ansi B16.5 A105	
16	Transmission System To Index	Magnetic Coupling	
17	Measuring Fluid	Air/Natural Gas/Non Corrosion Gas/...	
18	Casing	Steel	
19	Max Pressure Loss	3 mbar	

Fig. 3: Typical Error Curve

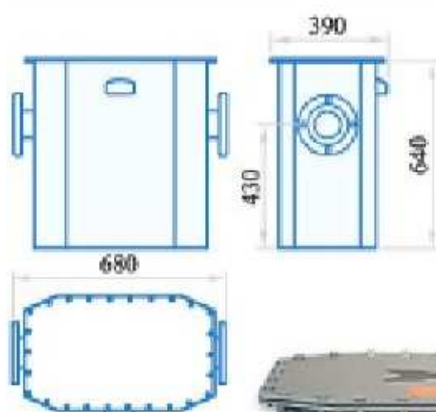
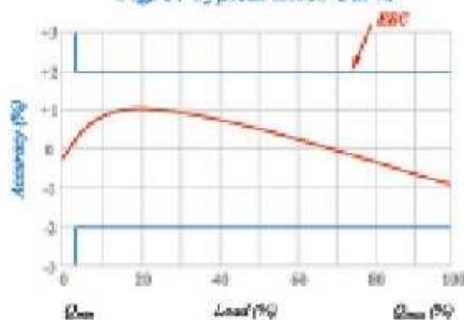
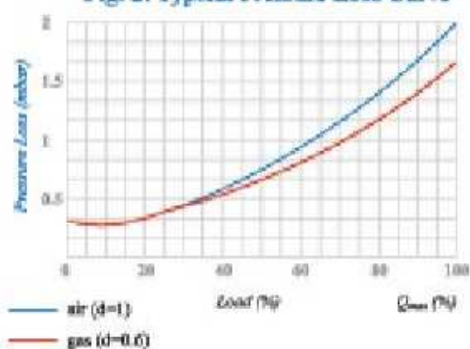

Fig. 2: Typical Pressure Loss Curve





TECHNICAL DATA

Fig. 1: GS-77-065A Dimension

ITEM	CHARACTERISTICS	FEATURES	COMMENTS
1	Type	GS-77-065A	
2	G-Rating	G65	
3	Max-Flow Rate (Q_{max})	100 m ³ /h	
4	Min-Flow Rate (Q_{min})	0.65 m ³ /h	
5	Cyclic Volume	55 dm ³	
6	Max-Operating Pressure	0.5 bar	
7	Number of Digits	6 Digits + 2 Decimal	
8	Scale Division	2 dm ³	
9	Ambient Temperature	-29° C ~ +60° C	
10	Accuracy	+3% For $Q_{min} < Q < 2Q_{min}$ +2% For $2Q_{min} < Q < Q_{max}$	
11	Normal Inlet Pressure	18 mbar	
12	ID/OD Size	3"	
13	Connection Type	Flange	
14	Connection Location	Side	
15	Flange Std	Ansi B16.5 A105	
16	Transmission System To Index	Magnetic Coupling	
17	Measuring Fluid	Air/Natural Gas/Non Corrosion Gas/...	
18	Casing	Steel	
19	Max Pressure Loss	4 mbar	

Fig. 3: Typical Error Curve

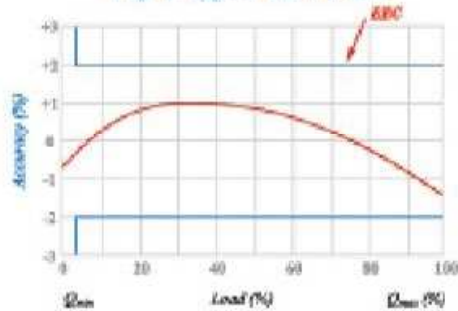
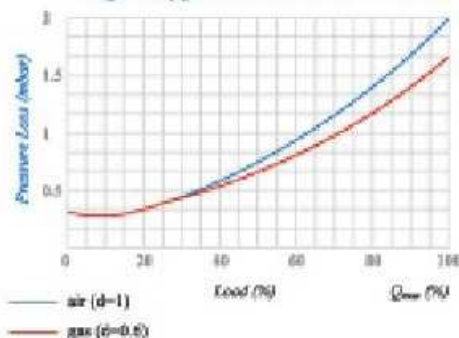

Fig. 2: Typical Pressure Loss Curve





TECHNICAL DATA

Fig. 1: GS-78-0100A Dimension

ITEM	CHARACTERISTICS	FEATURES	COMMENTS
1	Type	GS-78-0100A	
2	G-Rating	G100	
3	Max-Flow Rate (Q_{max})	160 m ³ /h	
4	Min-Flow Rate (Q_{min})	1 m ³ /h	
5	Cyclic Volume	120 dm ³	
6	Max-Operating Pressure	0.5 bar	
7	Number of Digits	7 Digits + 1 Decimal	
8	Scale Division	20 dm ³	
9	Ambient Temperature	-29° C ~ +60° C	
10	Accuracy	+3% For $Q_{min} < Q < 2Q_{min}$ +2% For $2Q_{min} < Q < Q_{max}$	
11	Normal Inlet Pressure	18 mbar	
12	ID/OD Size	4"	
13	Connection Type	Flange	
14	Connection Location	Side	
15	Flange Std	Ansi B16.5 A105	
16	Transmission System To Index	Magnetic Coupling	
17	Measuring Fluid	Air/Natural Gas/Non Corrosion Gas/...	
18	Casing	Steel	
19	Max Pressure Loss	4 mbar	

Fig. 3: Typical Error Curve

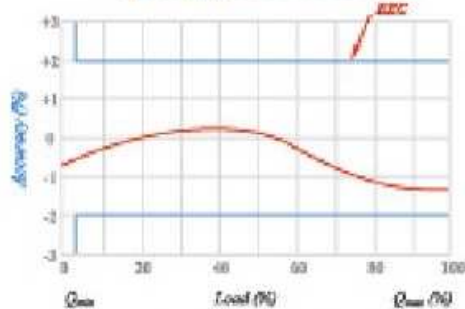
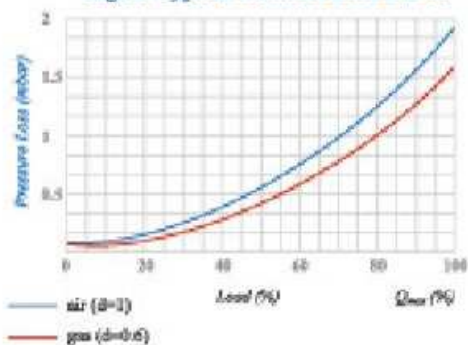

Fig. 2: Typical Pressure Loss Curve



TECHNICAL DATA

Fig. 1: GS-78-0160A Dimension

ITEM	CHARACTERISTICS	FEATURES	COMMENTS
1	Type	GS-78-0160A	
2	G-Rating	G160	
3	Max-Flow Rate (Q_{max})	250 m ³ /h	
4	Min-Flow Rate (Q_{min})	1.6 m ³ /h	
5	Cyclic Volume	120 dm ³	
6	Max-Operating Pressure	0.5 bar	
7	Number of Digits	7 Digits + 1 Decimal	
8	Scale Division	20 dm ³	
9	Ambient Temperature	-29° C ~ +60° C	
10	Accuracy	+3% For $Q_{min} < Q < 2Q_{min}$ +2% For $2Q_{min} < Q < Q_{max}$	
11	Normal Inlet Pressure	18 mbar	
12	ID/OD Size	4"	
13	Connection Type	Flange	
14	Connection Location	Side	
15	Flange Std	Ansi B16.5 A105	
16	Transmission System To Index	Magnetic Coupling	
17	Measuring Fluid	Air/Natural Gas/Non Corrosion Gas/...	
18	Casing	Steel	
19	Max Pressure Loss	4 mbar	

Fig. 3: Typical Error Curve

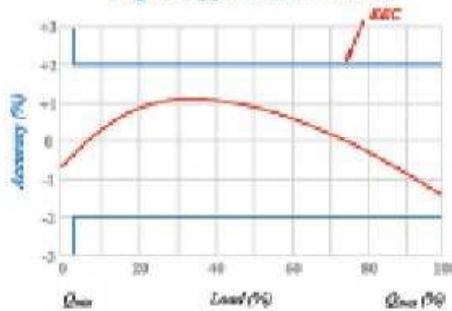

Fig. 2: Typical Pressure Loss Curve

