



**GLOVE BOX
ENVIRONMENTAL
CHAMBER**

MODEL: 34788-00, 34788-10

INSTALLATION AND OPERATION MANUAL

TABLE OF CONTENTS

Section 1.0	Receiving and Inspection
Section 2.0	Installation and Maintenance
Section 3.0	Pre Operation Procedures
Section 4.0	Operation
Section 5.0	Parts List Unit Specifications

Rev. 01/18/06
4861497

This unit is for professional, industrial or educational use where the preparation or testing of materials is done at approximately atmospheric pressure and no flammable, volatile or combustible materials are being heated. This unit is not intended for hazardous or household locations or use.

Section

1

RECEIVING AND INSPECTION

Your satisfaction and safety require a complete understanding of this unit. Read the instructions thoroughly and be sure all operators are given adequate training before attempting to put the unit in service. Note: This equipment must be used only for its intended application; any alterations or modifications will void your warranty.

- 1.1 **Inspection:** The carrier, when accepting shipment, also accepts responsibility for safe delivery and is liable for loss or damage. On delivery, inspect for visible exterior damage, note the describe on the freight bill any damage found, and enter your claim on the form supplied by the carrier.

Inspect for concealed loss or damage on the unit itself, both interior and exterior. If necessary, the carrier will arrange for official inspection to substantiate your claim.

- 1.2 **Return Shipment:** Save the shipping crate until you are sure all is well. If for any reason you must return the unit, first contact your Cole Parmer Customer Representative for authorization. Supply nameplate data, including model number and serial number. Please see the manual cover for information on where to contact Cole Parmer.
- 1.3 Verify that all of the equipment indicated on the packing slip is included with the unit. Carefully check all packaging before discarding. Each unit is equipped with a pair of Arm Port gloves, two (2) glove bands and Hygrometer.

INSTALLATION AND MAINTENANCE

Local city, county or other ordinances may govern the use of this equipment. If you have any questions about local requirements, please contact the appropriate local agency. Installation may be performed by the end user.

Under normal circumstances this unit is intended for use indoors, at room temperatures between 5 degrees and 40 degrees C, at no greater than 80% Relative Humidity (at 25 degrees C). Customer Service should be contacted for operating conditions outside of these limits.

Installation

- 2.1 **Location:** In selecting a location, consider all conditions that may effect performance, such as heat from radiators, ovens, autoclaves, etc. Avoid direct sun, fast moving air currents, heating/cooling ducts and high-traffic areas. Allow a minimum of 5cm between the unit and any walls or partitions that might obstruct free air flow.
- 2.2 **Lifting / Handling:** This unit is heavy and should only be lifted from the bottom surface. Doors, handles and knobs are not adequate for lifting or stabilization. The unit should be completely restrained from tipping during lifting or transport and doors need to be positively locked in the closed position during transfer to prevent shifting and damage.
- 2.3 **Leveling:** The unit must sit level and solidly. Leveling feet are not supplied, but the workbench should be level to provide optimum working and safety conditions.
- 2.4 **Cleaning:** Cleaning and decontamination are recommended on a regular basis. First clean the chamber with soap and water, rinse and let dry. To decontaminate use a solution that is appropriate for your application. DO NOT USE chlorine based-bleaches, solvents, or abrasives as this can damage the unit. Never clean the unit with alcohol or flammable cleaners with the unit connected to the gas supply. Always disconnect the unit from the gas supply when cleaning and assure all volatile or flammable cleaners are evaporated and dry before reattaching the unit to the supply.
- 2.5 **Hygrometer:** The Hygrometer is easily installed by sliding it onto the support bracket located in the upper right hand corner of the chamber. You will note that the display is always ON. The display can be changed to C degrees or F degrees by moving the switch at the back, the clock is changed by using the ADVANCE button. The MAX / MIN button displays the high and low points the meter has read which can be cancelled at any time by using the RESET button.

Installation (cont.)

- 2.6 **Gloves:** It is critical that the gloves are installed correctly and the sleeve cuffs seal around the Arm Port opening to ensure the desired controlled environment. Place the gloves through the Arm Ports and into the chamber then roll the sleeves back over and around the Arm Port opening. The sleeve opening has a beaded rim, which must be placed as far back, over the port and as close to the chamber, as possible. To create an air tight seal, secure the sleeve in place with the plastic coated band, placing it directly behind the bead, then tighten the band using a flat head screwdriver. Be very careful when tightening the bands as not to damage the gloves.
- 2.7 **Gas Source and Connection to Chamber:** Install a gas regulator that is appropriate for the type of gas you intend to use, to the tank. Chain the tank to a secure position on the wall and set the low pressure gauge between 1 to 3psi using the T-handle at the base to make adjustments (DO NOT EXCEED 3PSI). If Hydrogen gas is to be used DO NOT EXCEED 5% HYDROGEN CONCENTRATION WITH THE CHAMBER. DO NOT turn the gas regulator on until the chamber is ready to be purged.

The valve fitting for the gas connection is on the right side of the unit near the top and is marked GAS IN. Insert the tubing from the regulator, into the fitting at the base of the valve. The tubing should snap into place as it passes over the pull-stop and you should be able to pull the tubing without it coming loose. To disconnect the tubing, the fitting ring must be pulled up and away from the tubing to unlock the pull-stop while pulling the tubing out.

Maintenance

- 2.8 **Replacing Gloves:** When and how often the gloves need to be replaced depends on care and technique by the operator. Typically, the gloves are replaced about every three (3) months. Operators should examine the gloves and sleeves for small holes or tears that can appear during normal wear. If holes are present, the gloves should be replaced to avoid gas leakage. Watches and jewelry can damage the gloves and should not be worn during chamber use. Please see the parts list in section 5.0 for replacement gloves.
- 2.9 **Storage:** If the unit is to be shut down for storage or transporting, remove any equipment and samples from the chamber and remove the gloves from the Arm Ports. Turn off the gas regulator and disconnect the gas supply line (and VENT line if possible). Clean the chamber and Pass Box as described in 2.4. Dry the chamber and Pass Box then let stand at room temperature while open to ensure that it is completely dry so it will not become contaminated. Lock the access windows and outer Pass Box door closed then follow directions in 2.2 if transporting is necessary.

PRE OPERATION PROCEDURES

- 3.1 Open the front-access window, and place any equipment and materials into the chamber that will be needed. This should be done prior to purging the chamber with gas. Check the gloves for any tears or punctures before using. If any are noted the gloves should be replaced immediately. Please refer to the parts list in section 5.0 for replacement gloves.
- 3.2 **Pressure Adjustment:** This unit is not designed to be a vacuum or pressure chamber, therefore the VENT valve should be open during gassing to allow displacement of atmosphere. The VENT valve is located on the right side near the bottom front. The gloves can be used as an indicator of pressure within the chamber as they will begin to push out of the Arm Ports and start filling with gas. Adjust the VENT valve opening as necessary to maintain an equal pressure. If the pressure within the chamber becomes too great, the gloves will balloon out of the chamber completely and eventually burst. Note that tubing can be connected to the VENT valve in the same manner as the GAS IN valve if operations require it; however, it is NOT TO BE USED for connecting a vacuum.
- 3.3 **Gas Conservation:** Operators evaluate and try to limit the number of times the Pass Box is opened in order to conserve gas. Gas consumption can be reduced by balancing arm movements. For example, when extending the right arm into the chamber, bring the left arm close to the front of the chamber to balance the pressure. A solid object can be placed in the Pass Box or chamber to reduce the amount of gas in the cubic area, limiting the amount of atmosphere exchanged.

Section

4

OPERATION

- 4.1 **Purging the Chamber:** To purge the glove box, the gas regulator low pressure gauge must be set as described in section 2.7. Be certain that the front and top access windows and outer Pass Box door are closed and that the inner Pass Box door is partially opened. Open the GAS IN valve on the unit and turn the gas on at the tank to begin purging. When the gloves begin to fill with gas and slightly extend from the glove ports (approximately 10 to 15 minutes) turn the gas regulator off and close the GAS IN valve. Place your hands in the gloves to balance the pressure then close the inner Pass Box door. Slowly remove your hands from the gloves then close the VENT valve.
- 4.2 **Continual Purge:** A continual gas flow may be necessary for some types of applications. In these cases, it is essential that an equal pressure be maintained by having the VENT valve opened and that the gloves do not balloon outward. This may require lowering the gas supply pressure, adjusting the VENT valve or both.
- 4.3 **Maintaining Humidity Levels:** The chamber Hygrometer will display the humidity level. If lower humidity levels are required, desiccant packs are readily available (note that desiccants can dry out samples) or a Drying Column can be installed on the supply line instead of desiccants inside the chamber. Please see the parts list in section 5.0 for a list of these products. A specific gas type may be necessary as some gasses are better for humidity control than other's, for example, Nitrogen. Humidity can also vary due to the sample type, so variables may require that more than one type of gas be on hand at any one time.

Section

5

Parts List

Description	Part Number
Drying Column	07193-00
Glove Clamp	95813-40
Gloves, pr	34790-80
High absorption Desiccant, 1 lb	24450-00
High absorption Desiccant, 5 lb	24450-10
High absorption Desiccant, 50 lb	24450-20
Hygrometer	37802-00
Indicating Desiccant, 1 lb	07193-05
Indicating Desiccant, 5 lb	07193-15
Indicating Desiccant, 25 lb	07193-18

UNIT SPECIFICATIONS

Model 34788-00

TOP VIEW

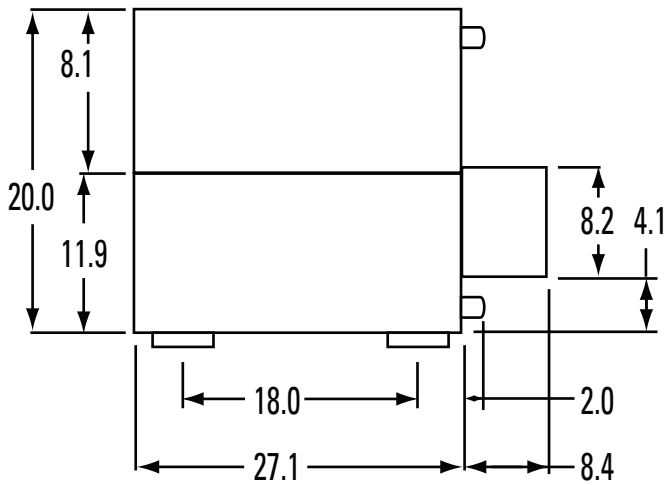

Dimensions in inches
 Net Weight = 48 pounds
 Ship Weight = APPROX 105 lbs

FRONT VIEW

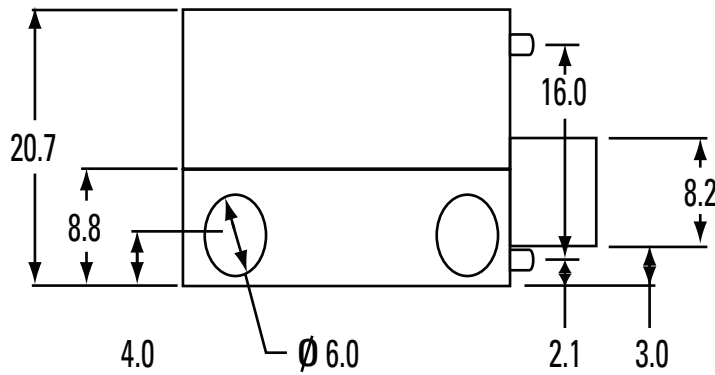

PASS BOX SIDE VIEW

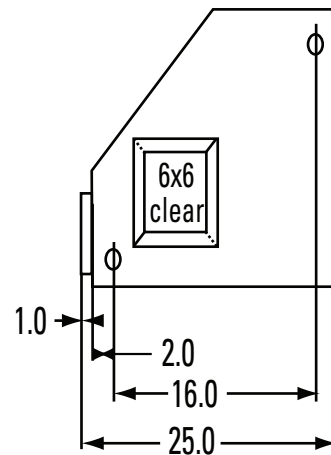

9830510US

UNIT SPECIFICATIONS

Model 34788-10

TOP VIEW

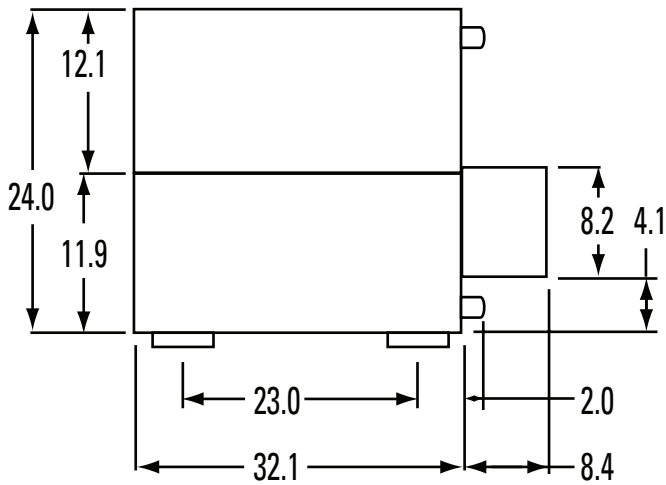

Dimensions in inches
 Net Weight = 65 pounds
 Ship Weight = APPROX 120 lbs

FRONT VIEW

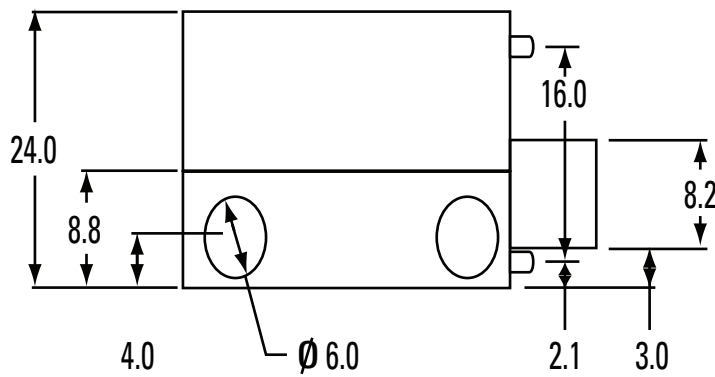

PASS BOX SIDE VIEW

