



DR/820, DR/850, and DR/890

**Portable Datalogging Colorimeter
Instrument Manual**

TABLE OF CONTENTS

SAFETY PRECAUTIONS	3
SPECIFICATIONS	4
OPERATION	
SECTION 1 GENERAL DESCRIPTION	7
1.1 Instrument Description	7
1.2 Unpacking the Instrument	8
1.2.1 Standard Accessories	9
1.2.2 Optional Accessories	9
1.3 Description of the Keypad.....	9
1.4 Display Screen in Function and Numeric Modes.....	12
1.5 Icon and Display Screen.....	12
SECTION 2 INSTRUMENT SETUP	15
2.1 Battery Installation	15
2.2 Turning the Instrument On.....	17
2.3 Setting the Date and Time.....	17
2.3.1 Entering the Correct Date	17
2.3.2 Entering the Correct Time	18
2.4 Sample Cell Insertion	19
2.5 Sample Cell Adapter Installation	19
2.5.1 Using the 16-mm COD/Test 'N Tube Vial Adapter.....	19
2.6 Using the Instrument Cap as A Light Shield.....	20
SECTION 3 INSTRUMENT OPERATION	21
3.1 Menus	21
3.1.1 Setup Menu	21
3.1.2 Recall Menu.....	22
3.2 Performing an Analysis	22
3.2.1 Colorimeter Setup for Sample Analysis	23
3.2.2 Sample Preparation.....	24
3.2.3 Zeroing the Colorimeter	24
3.2.4 Measuring the Prepared Sample	24
3.2.5 Alternate Chemical Forms	25
3.2.6 Using the Timer	25
3.2.6.1 Using the Timer in Manual Mode.....	25
3.2.6.2 Stopping the Timer	26
3.3 Reagent Blank Correction	26
3.4 Adjusting the Standard Curve	27
3.5 Using a Programmed Method	29
3.6 Quality Assurance	30

TABLE OF CONTENTS

SECTION 4 CREATING USER-ENTERED PROGRAMS	31
4.1 User-Entered Programs.....	32
4.2 Calibration Curves	32
4.3 User-entered Program Information for Bleaching Chemistries.....	32
4.4 Creating a New User-entered Program.....	33
4.5 Reviewing and Editing User-Entered Programs.....	36
4.6 Erasing User-entered Programs	37
SECTION 5 DATA RECALL AND STORAGE	39
5.1 Recalling Data.....	39
5.2 Erasing All Stored Data	40
SECTION 6 PRINTING AND DATA TRANSFER	43
6.1 Data Transfer Adapter Basics	43
6.1.1 Attaching the Data Transfer Adapter	43
6.2 RS232 Connections.....	44
6.2.1 Setup and Use of the Printer.....	45
6.2.2 Connecting to a Personal Computer.....	46
6.3 Sending Data to a Printer or Computer.....	47
6.3.1 Sending Currently Displayed Data.....	47
6.3.2 Sending Recalled Data	48
6.3.3 Sending All Stored Data.....	48
SECTION 7 MAINTENANCE	51
7.1 Cleaning the Colorimeter.....	51
7.1.1 Cleaning the Data Transfer Adapter.....	51
7.1.2 Sample Cells.....	51
7.2 Replacement Instructions.....	51
7.2.1 Battery Replacement	51
SECTION 8 TROUBLESHOOTING	53
8.1 Introduction.....	53
8.1.1 Error Codes	53
8.1.2 Beeper/Error Icon.....	54
8.1.3 Concentration Out of Range.....	54
8.1.4 Low Battery.....	54
GENERAL INFORMATION	
REPLACEMENT PARTS AND ACCESSORIES	57
How To Order	59
Repair Service.....	60
Warranty	61
CERTIFICATION	63

SAFETY PRECAUTIONS

Before attempting to unpack, set up or operate this instrument, please read this entire manual. Pay particular attention to all warnings, cautions and notes. Failure to do so could result in serious injury to the operator or damage to the equipment.

To ensure the protection provided by this equipment is not impaired, this equipment **MUST NOT** be installed or used in any manner other than that which is specified in this manual.

Use of Hazard Information

If multiple hazards exist, the signal word corresponding to the greatest hazard shall be used.



DANGER

Indicates either a potentially or an imminently hazardous situation which, if not avoided, could result in either death or serious injury.



CAUTION

Indicates a potentially hazardous situation that may result in minor or moderate injury.

NOTE

Information that requires special emphasis.

Precautionary Labels

Please pay particular attention to labels and tags attached to the instrument. Personal injury or damage to the instrument could occur if not observed.

The DR/800 Series Colorimeters are Class 1 LED products. A Class 1 LED product has insufficient energy to be considered an eye hazard.

	<p>Electrical equipment marked with this symbol may not be disposed of in European public disposal systems after 12 August of 2005. In conformity with European local and national regulations (EU Directive 2002/96/EC), European electrical equipment users must now return old or end-of life equipment to the Producer for disposal at no charge to the user.</p> <p>Note: For return for recycling, please contact the equipment producer or supplier for instructions on how to return end-of-life equipment, producer-supplied electrical accessories, and all auxiliary items for proper disposal.</p>
	<p>This is the safety alert symbol. Obey all safety messages that follow this symbol to avoid potential injury. If on the instrument, refer to the instruction manual for operation or safety information.</p>



Section 2.1 Battery Installation



SECTION 4 CREATING USER-ENTERED PROGRAMS

SPECIFICATIONS

Specifications subject to change without notice.

Wavelength Range(s):

- Model DR/890: 420, 520, 560, 610 nm
- Model DR/850: 520, 610 nm
- Model DR/820: 520 nm

Wavelength Accuracy: ± 1 nm

Wavelength Selection: Automatic

Photometric Linearity: ± 0.002 A (0-1 A)

Photometric Reproducibility: ± 0.005 A (0-1 A)

Photometric Accuracy: ± 0.005 A @ 1.0 ABS Nominal

Source Lamp: Light Emitting Diode (LED)

Detector: Silicon Photodiode

Data Readout: 4-digit LCD, 1.5-cm Character Height

Readout Modes: % Transmittance, Absorbance, Concentration

External Outputs: IR (Infrared to RS-232 Serial using the Data Transfer Adapter)

Battery Power: (4) AA alkaline cells

Instrument Dimensions: 23.6 x 8.7 x 4.7 cm (9.3 x 3.4 x 1.9 inches)

Instrument Weight: 470 g (1 lb.)

Photometric Range: 0-2 A

Stray Light: <1.0% at 400 nm

Battery Life: 6 months (typical)

Temperature Range:

Operating Range: 0 to 50 °C (32 to 122 °F)

Storage Range: -40 to 60 °C (- 40 to 140 °F)

Humidity: 90% at 50 °C

Environmental: Designed to meet IP67 Standard; dustproof and waterproof



OPERATION

DANGER

Handling chemical samples, standards, and reagents can be dangerous. Review the necessary Material Safety Data Sheets and become familiar with all safety procedures before handling any chemicals.

DANGER

La manipulation des échantillons chimiques, étalons et réactifs peut être dangereuse. Lire les Fiches de Données de Sécurité des Produits (FDSP) et se familiariser avec toutes les procédures de sécurité avant de manipuler tous les produits chimiques.

PELIGRO

La manipulación de muestras químicas, estándares y reactivos puede ser peligrosa. Revise las fichas de seguridad de materiales y familiarícese con los procedimientos de seguridad antes de manipular productos químicos.

GEFAHR

Das Arbeiten mit chemischen Proben, Standards und Reagenzien ist mit Gefahren verbunden. Es wird dem Benutzer dieser Produkte empfohlen, sich vor der Arbeit mit sicheren Verfahrensweisen und dem richtigen Gebrauch der Chemikalien vertraut zu machen und alle entsprechenden Material Sicherheitsdatenblätter aufmerksam zu lesen.

PERIGO

A manipulação de amostras, padrões e reagentes químicos pode ser perigosa. Reveja a folha dos dados de segurança do material e familiarize-se com todos os procedimentos de segurança antes de manipular quaisquer produtos químicos.

1.1 Instrument Description

The Hach DR/800 Series Colorimeter shown in *Figure 1* is a microprocessor-controlled, LED-sourced filter photometer suitable for colorimetric testing in the laboratory or the field. The instrument is precalibrated for common colorimetric measurements and includes convenient calibration capability for user-entered and future Hach methods. Instrument features include:

- Test results are displayed in concentration, absorbance, or percent transmittance.
- Automatic wavelength selection and ranging in the preprogrammed parameters.
- Data storage and recall for datalogging in the field or laboratory.
- Conversion of results to alternate forms for many parameters (i.e., PO₄, P₂O₅, P).
- Reagent Blank Correction and Standard Adjust features may be used to compensate for lot-to-lot variations in reagents.
- Icon prompts displayed during testing.
- A built-in timer to monitor specific reaction times called for in the test procedures. Appropriate times are programmed into the calibration data for specific tests. The timer also can be used manually by the operator independent of the stored methods.
- IR output for RS232 interface capability allows an external printer or computer to interface with the colorimeter.
- Entry of user-entered methods or new Hach methods.
- Error signals for procedural or instrument troubleshooting.

The colorimeter operates on battery power. The instrument holds four AA-size alkaline dry cells (batteries supplied) that power the instrument for at least six (6) months.

SECTION 1, continued

Figure 1 DR/800 Series Colorimeter Standard Package*



1.2 Unpacking the Instrument

Remove the instrument and accessories from the shipping container and inspect each item for any damage that may have occurred during shipping. Verify that all items listed on the packing slip are included. If any items are missing or damaged, please contact Hach Customer Service, Loveland, Colorado for instructions.

* Carrying Case may be ordered separately.

SECTION 1, continued

Hach's toll-free number for customers within the United States is 800-227-4224. For customers outside the United States, contact the Hach office or distributor serving you.

1.2.1 Standard Accessories

- Sample Cells — (2) round, 1-inch pathlength, glass, with 10-mL, 20-mL, and 25-mL marks; (2) 1-cm pathlength, plastic
- COD/TNT Adapter for use with 16-mm vials used in COD and Test 'N Tube methods.
- Batteries — (4) AA alkaline
- Documentation package — includes Instrument Manual and Procedures Manual.

In addition to these standard accessories, several other optional accessories are available from Hach Company (refer to *Replacement Parts and Accessories*).

1.2.2 Optional Accessories

- Data Transfer Adapter (for RS232 interface)
- HachLink™ Software
- Instrument case
- DR/Check™ ABS Standard

1.3 Description of the Keypad

Figure 2 shows the colorimeter's keypad. The description and function of each individual key is given in *Table 1*.

SECTION 1, continued

Figure 2 Keypad

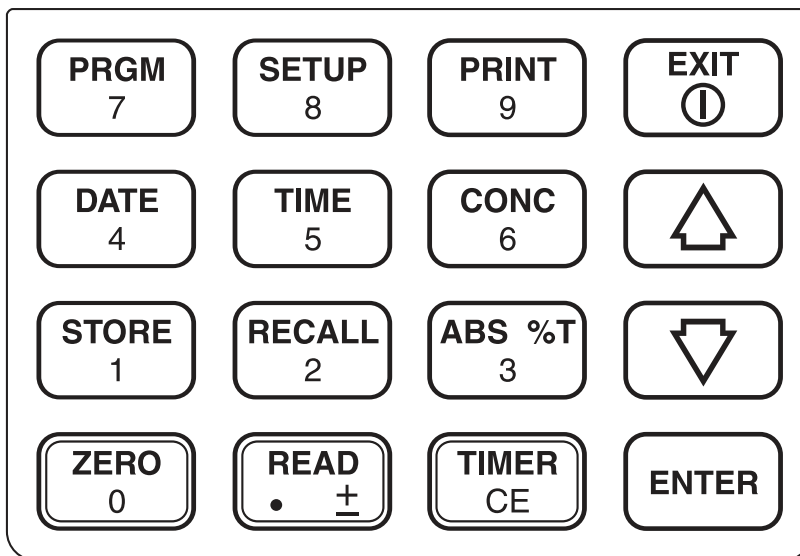

















Table 1 Keys and Descriptions

KEY	DESCRIPTION
	Allows the user to select a program. Also used as a numeric key function when the “#” icon is illuminated at the base of the display screen.
	Accesses the SETUP menu (the SETUP icon illuminates in the upper left-hand corner of the display screen). The setup menu provides access to options such as reagent blank, standard adjust, user-entered programs, and instrument configurations. Also used as a numeric key function when the “#” icon is illuminated at the base of the display screen.
	Prints currently displayed data. In the RECALL menu, prints recalled data. Also used as a numeric key function when the “#” icon is illuminated at the base of the display screen.
	Use this key to turn the instrument on and, when the instrument is on and the EXIT icon is not illuminated, press this key to turn the instrument off. When the EXIT icon is illuminated at the base of the display screen, the EXIT key cancels the current entry or selection.

SECTION 1, continued

Table 1 Keys and Descriptions (Continued)

KEY	DESCRIPTION
	Displays the current date. In the RECALL menu, displays the date the recalled sample was stored. Also used as a numeric key function when the “#” icon is illuminated at the base of the display screen. Used to set the current date from the SETUP menu.
	Displays the current time. In the RECALL menu, displays the time the recalled sample was stored. Also used as a numeric key function when the “#” icon is illuminated at the base of the display screen. Used to set the current time from the SETUP menu.
	When performing an analysis, this key displays the concentration value of the reading. Used as a toggle key to access alternate chemical forms, if available. Also used as a numeric key function when the “#” icon is illuminated at the base of the display screen.
	Scrolls up through selected menus or stored data.
	When performing an analysis, this key allows the user to store a current reading in one of 99 sample locations. The user can store the reading as numbers 1-99 by pressing ENTER . Use the up and down arrow keys to find unused storage numbers or use numeric keys to enter a sample number. Also used as a numeric key function when the “#” icon is illuminated at the base of the display screen.
	Begins the retrieval of stored sample readings (RECALL icon illuminates in the upper-left portion of the screen). Also used as a numeric key function when the “#” icon is illuminated at the base of the display screen.
	Toggles between displaying Absorbance and % Transmittance. Also used as a numeric key function when the “#” icon is illuminated at the base of the display screen.
	Scrolls down through selected menus or stored data.
	Zeros the instrument on the current sample blank. Also used as a numeric key function when the “#” icon is illuminated at the base of the display screen.
	When the READ icon is illuminated at the base of the display screen, this key reads and displays the sample concentration. Also used as a numeric key function when the “#” icon is illuminated at the base of the display screen; the first press is a decimal, the second press toggles the value sign.
	If using a Hach-stored program, the TIMER key automatically sets the appropriate reaction time. If not in a Hach-stored program, the TIMER key allows the user to set a timer. When the “#” icon is illuminated at the base of the display screen, CE clears the most recent level of action (deletes the whole entry, not just the last number).
	Within a menu, selects the displayed menu item. During numeric entry, accepts the displayed value.

1.4 Display Screen in Function and Numeric Modes

The main display operates in two modes: function mode and numeric mode. The user does not select the mode, changeover is automatic depending on the options selected, where the user is in an analysis, and what information the instrument needs from the user.

The main display shows action icons (**ZERO** and **READ**) displayed below the horizontal line. This shows there are two available options to select (zero the instrument, or take a reading) at this point in the analysis.

The numeric mode is signified by the “#” icon illuminated below the horizontal line. In the numeric mode, some function keys act as numeric entry keys (corresponding to the number on the key).

1.5 Icon and Display Screen

Figure 3 shows the icons displayed by the DR/800 Series Colorimeters. Table 2 provides a brief description of each display element.

Figure 3 Icon and Main Display Screen

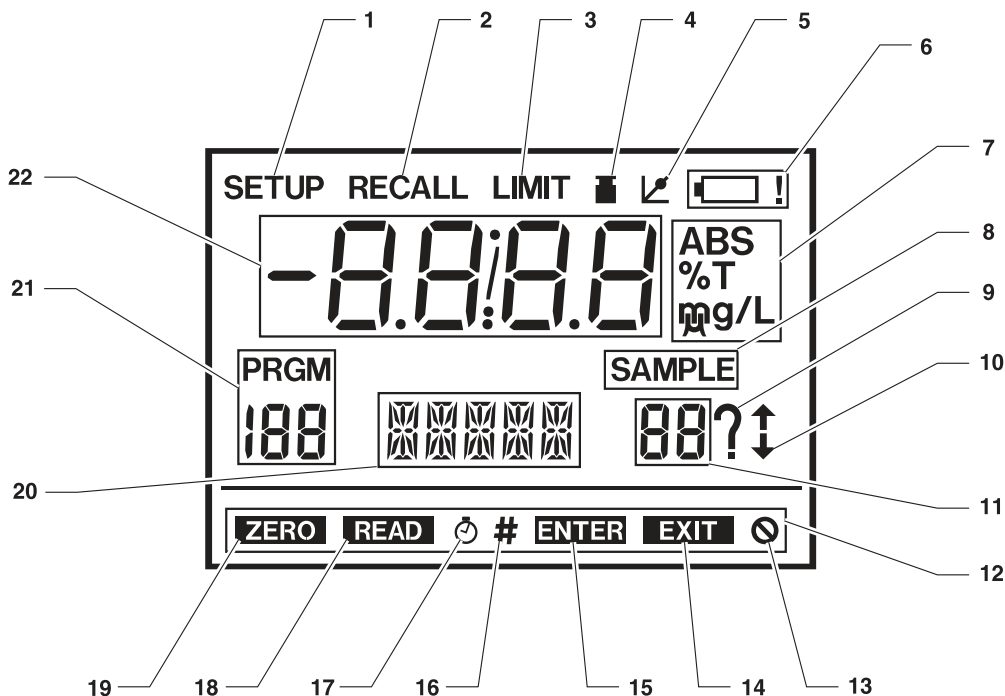

SECTION 1, continued

Table 2 Main Display Screen Icons

ITEM NO.	DEFINITION
1	Indicates the user is in the SETUP menu.
2	Indicates the user is in the RECALL menu.
3	The sample concentration exceeds the limits of the selected program.
4	Sample cell icon. Indicates a reagent blank adjustment is in use for the current program.
5	Standard adjust icon. Indicates a standard adjust is in use for the current program.
6	Indicates a low battery condition - replace the batteries as soon as possible.
7	These three icons follow the sample reading and represent either absorbance, percent transmittance, milligrams per liter, micrograms per liter, or grams per liter.
8	Illuminates whenever the numbers in the main display (22) or the sample display (11) refer to a sample number.
9	Indicates the instrument is waiting for information from the user.
10	Depending on the arrow(s) illuminated, these icons indicate the available scroll direction (using the ARROW keys) for accessing options.
11	In the RECALL menu or when storing data, these digits show the selected sample number.
12	Most icons displayed in this area are action icons. Action icons tell the user what actions are acceptable options during an analysis.
13	Indicates an invalid key press was made. This icon flashes briefly accompanied by a short beep.
14	Exit action icon - (when illuminated) tells the user that pressing the EXIT key to exit the current level of action is an acceptable option.
15	Enter action icon - (when illuminated) tells the user that pressing the ENTER key to confirm an action is an acceptable option.
16	Numeric entry action icon - (when illuminated) tells the user the numeric key pad is active.
17	Timer action icon - (when illuminated) tells the user that the instrument is presently running a timer. This icon will flash while the timer is counting.
18	Read action icon - (when illuminated) tells the user that pressing the READ key to read the sample cell is an acceptable option.
19	Zero action icon - (when illuminated) tells the user that pressing the ZERO key to zero the instrument on a sample cell is an acceptable option.
20	Depending on the currently active menu, the series of alphabetical letters displayed here gives information on a current reading, a stored reading, indicates the options available within a menu, or prompts the user for the next action.
21	Shows the active program number, (either a user-entered (101-110) or Hach-stored program (1-100)). The program number is displayed immediately below the PRGM icon.
22	Depending on the currently active menu, the numbers displayed here represent either the sample reading, the clock timer, or the numeric characters entered by the user.

2.1 Battery Installation

Power is supplied by four AA-sized alkaline batteries. Typically, a set of batteries provides approximately six months of operation. The colorimeter lamp is an LED and is on only long enough for the measurement sequence to take place (approximately 2 seconds).

The instrument will automatically shut off if no keystrokes are made for 15 minutes when in normal mode and four hours when in user-entry mode.

Figure 4 provides an exploded view of the battery installation. When replacing discharged batteries, always replace the complete set of four.

Hach recommends using alkaline batteries in this instrument. **Do not use rechargeable Nickel Cadmium (NiCad) batteries.**

The battery compartment is accessible from the underside of the instrument. Make sure the sample cell compartment is empty. Lay the instrument upside down on a padded surface, and install batteries as follows:

Note: For performance reasons, never remove the battery cover from this product except when servicing the batteries.

1. Disconnect the Data Transfer Adapter (if connected) from the instrument.
2. Loosen the two battery compartment screws and remove the battery compartment door as shown in *Figure 4*.
3. Install four AA alkaline batteries in the battery holder as shown in *Figure 4*. Match the polarities of the batteries with the polarity markings in the battery compartment.
4. Replace the battery compartment cover, tighten the screws, and return the instrument to the upright position.



DANGER

Use of nickel-cadmium batteries under a fault condition creates a potential fire hazard.

PELIGRO

La utilización de pilas de níquel-cadmio en condiciones de falla crea el riesgo de incendio.

SECTION 2, continued

PERIGRO

O uso de baterias de níquel-cádmio em condição de falha cria a possibilidade de incêndio.

DANGER

L'utilisation de batteries nickel-cadmium dans des conditions inappropriées crée un risque d'incendie.

GEFAHR

Unter einer Störungsbedingung stellt die Verwendung von Nickel-Kadmium-Batterien eine Feuergefahr dar.

Figure 4 **Battery Installation**

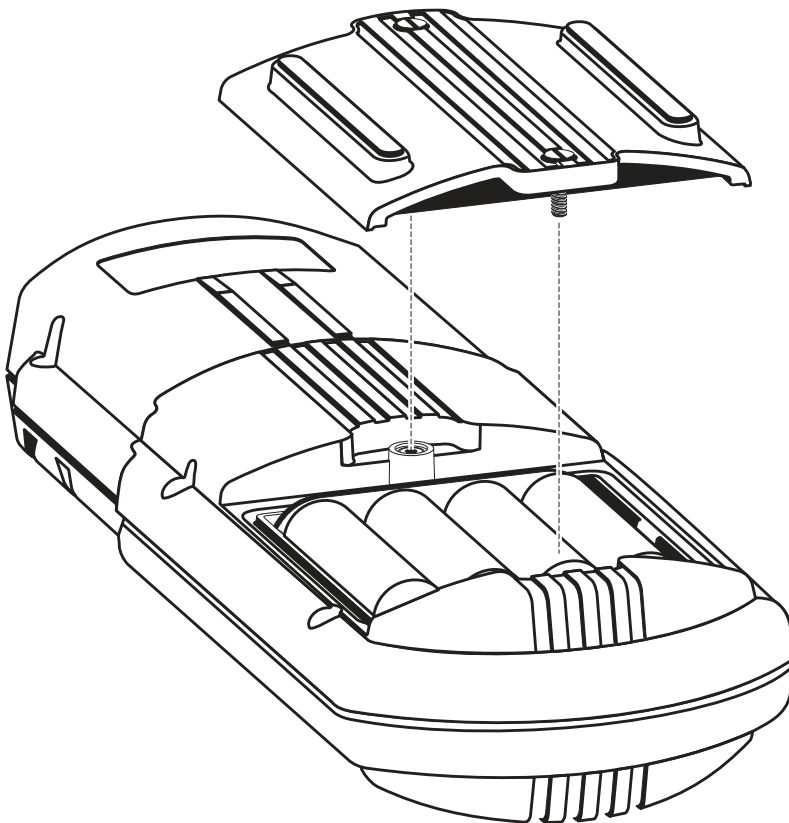

SECTION 2, continued

2.2 Turning the Instrument On

Once batteries are installed, turn the instrument on using the **EXIT/IO** key (located on the top row, far-right column of the instrument keypad).

Press the key once to power-on the instrument. The display will show the software version number, then will default to the last used program number. The instrument is now ready for operation.

2.3 Setting the Date and Time

Setting the instrument's date and time allows sample readings to be stored and recalled with the proper date and time. Check the currently entered date or time by pressing the respective **DATE** or **TIME** key.

To set the date and time, continue with Section 2.3.1 or 2.3.2 below.

2.3.1 Entering the Correct Date

Check the current date by pressing the **DATE** key. If the date is incorrect, follow the procedure below to change it.

Enter the correct year, then the correct month and day as follows:

1. Press the **IO** key to turn the instrument on.
2. Access the **SETUP** menu by pressing the **SETUP** key on the keypad. (The down **ARROW** icon on the right side of the display is shown.)
3. Press the down **ARROW** key until **DATE** is displayed.
4. Press the **ENTER** key to select the date option.
5. Four horizontal lines (showing available spaces for numeric entry) and **YEAR ?** will appear on the display. Enter the digits corresponding to the correct year using the numeric keypad. For instance, if the year is 1997, press **1 9 9 7** then the **ENTER** key.

If an incorrect number is entered, press the **CE** key and re-enter the information.

SECTION 2, continued

Next, the instrument prompts for the month and day.

6. Enter the correct month and day using the numeric keypad. The month must be entered first, followed by the day. If an incorrect number is entered, press the **CE** key and re-enter the information.

Note: When entering a one digit month or day, always press the **ZERO** key before the digit. For example: If the month and day to be entered is March 4, press **0 3 0 4** on the numeric keypad, then press the **ENTER** key to accept.

7. Press the **ENTER** key to accept the new information. Press the **EXIT** key to return to the main menu

2.3.2 Entering the Correct Time

1. Press the **I/O** key to turn the instrument on.
2. Access the **SETUP** menu by pressing the **SETUP** key on the keypad. (The down **ARROW** icon on the right side of the display is shown.)
3. Press the down **ARROW** key until **TIME** is displayed.
4. Press the **ENTER** key to select the time option.
5. Enter the time in 24-hour (military) notation using the numeric keypad then press the **ENTER** key to accept the entry. For example, 9:00 a.m. is entered as **0 9 0 0 ENTER** and 2:00 p.m. is entered as **1 4 0 0 ENTER**. If an incorrect number is entered, press the **CE** key and re-enter the information.
6. The display returns to the setup menu. Press the **EXIT** key to return to the main menu.

SECTION 2, continued

2.4 Sample Cell Insertion

Wipe the sample cell with a lint-free cloth or tissue and insert the cell into the sample cell compartment with the diamond-shaped marker toward the keypad.

Figure 5 Placing Samples in the Sample Cell Compartment



2.5 Sample Cell Adapter Installation

When installing an adapter into the sample cell compartment, insert the adapter into the cell compartment and rotate until it drops into the alignment slots. Finish installation by gently pushing down on the adapter until it snaps into position.

Place the appropriate vial or sample cell into the adapter - the vial or sample cell should fit well into the adapter. If it does not, double-check that the correct sample container (vial or sample cell) is being used and that the adapter is installed correctly.

2.5.1 Using the 16-mm COD/Test 'N Tube Vial Adapter

The methods for chemical oxygen demand (COD) and Test 'N Tube (TNT) determinations in the colorimeter procedures manual use 16-mm vials as the sample cell for the colorimetric measurement. This adapter also holds a standard 16-mm test tube.

Place the COD/TNT Adapter in the instrument's sample cell compartment as instructed in Section 2.5, above. Place the vial into the COD/TNT Adapter (see *Figure 6*).

Always place the instrument cap over the adapter when measuring in bright sunlight (see *Figure 7*).

SECTION 2, continued

Figure 6 Installing the COD/TNT Adapter

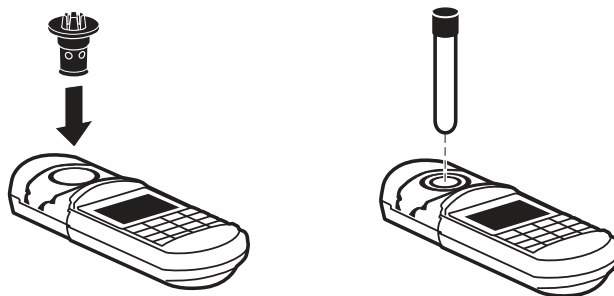

2.6 Using the Instrument Cap as A Light Shield

The colorimeter cap is removable (by sliding it away from the keypad) to expose the sample cell compartment. The instrument cap also functions as a light shield. Samples may be analyzed without the light shield in place but using the light shield provides a good seal against stray light and contributes to more accurate results. Use of the light shield is especially important when performing an analysis in bright light or direct sunlight.

To use the instrument cover as a light shield during measurements, place the cap over the sample cell, into the grooved marks on the instrument. See *Figure 7*.

Figure 7 Installing the Light Shield

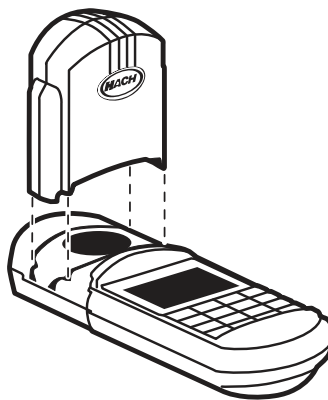

3.1 Menus

The instrument has two important menus which allow access to different options. The menus are:

- Setup Menu
- Recall Menu

Once the user has selected the desired menu, the arrow icons illuminate on the main display screen. The arrows indicate that additional options are available in this menu. Press the up or down **ARROW** key (whichever arrow is illuminated) to scroll until the desired option is displayed. A press of the **ENTER** key at this time selects the displayed option.

When choosing options from menus, the up or down **ARROW** keys, **ENTER**, and **EXIT** keys help navigate between menus and within menu options. Use the **ENTER** key to select a menu option. Press **ENTER** again to accept a new setting. Pressing the **EXIT** key leaves a menu or leaves the displayed item unchanged.

3.1.1 Setup Menu

Enter the **Setup Menu** from the **Main Menu** by pressing the **SETUP** key.

Refer to the arrow icons on the main display for an indication of which key (up **ARROW** or down **ARROW**) to press on the keypad - the direction of the illuminated icon on the main display indicates the available scrolling direction. The up and down **ARROW** (scroll) keys move from one menu option to the next.

Example: when the down arrow icon is illuminated on the display screen, the user only has the option to press the down **ARROW** key to move from one option to the next. Once the user scrolls down, the down arrow icon changes to a dual-direction arrow icon (up and down arrows) until the user reaches the last menu option available in that menu.

The following instrument operating features are available in the **Setup** menu

- **BLANK** - Used to compensate for color contributed by the reagents in a reagent blank. Readjust for each new lot of

SECTION 3, continued

reagents. Press the **ENTER** key to activate this option. The default setting is off. Chemistries which zero on a reagent blank do not have this option available.

Note: The *BLANK* and/or *STD* options may or may not be available, depending on the selected *Hach* program; the *BLANK* and *STD* options are always available for user-entered programs.

- **STD** - Standard Adjust option allows for entry of the value of the prepared standard. Press the **ENTER** key to activate this option. The default setting is off.
- **PRINT (ALL)** - Prints all stored data to a printer or downloads it to a personal computer. The information printed includes: sample concentration reading, date of sample, time of sample, units, sample number, program number, Absorbance, and %T. Refer to Section *SECTION 6* for detailed printing information and to *Figure 10* for an example of a printout. Press the **ENTER** key to activate this option.
- **USER** - Allows access to the User-Entered Program Menu. Press the **ENTER** key to activate this option. See *Creating a New User-entered Program* on page 33 for more information.
- **DATE** - Allows the user to set the date. Press the **ENTER** key to activate this option. See Section 2.3.1 for more information.
- **TIME** - Allows the user to set the time. Press the **ENTER** key to activate this option. See Section 2.3.2 for more information.
- **ERASE (ALL)** - This clears all the data previously stored in memory. Press the **ENTER** key to activate this option.

3.1.2 Recall Menu

The recall menu allows access to stored data. Complete information and instructions for the use of this menu is presented in *SECTION 5 DATA RECALL AND STORAGE*.

3.2 Performing an Analysis

The procedures manual provides illustrated, step-by-step procedures for performing all the factory-entered methods. This instrument manual has supplemental information on how the instrument performs the necessary functions, and how to use the special operating features. Once you are familiar with the

SECTION 3, continued

instrument, the instructions in the procedure manual should be sufficient to analyze your samples.

Colorimetric testing with preprogrammed calibrations can be divided into four general phases:

1. Colorimeter setup
2. Sample preparation
3. Zeroing the instrument
4. Measuring the prepared sample

The following sections describe each phase in detail.

3.2.1 Colorimeter Setup for Sample Analysis

The colorimeter setup using a Hach program begins by selecting the desired program number. Programs numbers can be found in the individual procedure. (See the DR/800 Series Procedures manual supplied with your instrument.) Prompting icons will appear to indicate which keys are acceptable for the user to select. After turning the instrument on, the main display shows information from the last program used before the instrument was turned off.

If a different program is desired, press the **PRGM** key and enter the desired program number with the numeric keypad. The instrument will recall that program.

If the number selected is not valid, an error signal sounds and the display momentarily flashes an error icon. The display returns to the prompt for the program number. Re-enter the correct program number. Only select chemistries are available on the DR/820 and DR/850. See *APPENDIX A AVAILABLE PARAMETERS AND RANGES* on page 65.

When the program number has been successfully entered, the display immediately prompts the user to zero the instrument by illuminating the **ZERO** action icon.

SECTION 3, continued

3.2.2 Sample Preparation

For colorimetric tests, sample preparation is next. The zero solution (or blank) and sample are usually prepared at this time. Generally, sample preparation consists of adding the contents of a premeasured reagent pillow to a small volume of sample. Follow the instructions in the procedure specific to your analysis.

It is important to observe the waiting period specified in the test procedure to ensure the color from the reaction of the reagent(s) with the target analyte develops fully. Many procedures also give a maximum time limit after which the color may begin to fade.

The instrument has method-specific timers for color development times pre-programmed into the software. The user is notified when the time has elapsed by a series of short beeps.

3.2.3 Zeroing the Colorimeter

The instrument must be zeroed for each test or series of tests to establish a zero reference for the measurement. This is done by placing a solution recognized as the blank solution in the cell holder, covering the sample with the instrument cap, and pressing the **ZERO** key. The next prompt will display zeros and illuminate the **READ** action icon. The instrument is now ready to take the first sample reading.

***Note:** Once the zero reference point has been established, several samples can be measured consecutively by placing each of them into the cell holder and pressing the **READ** key. The instrument can be re-zeroed at any time by placing the zero solution (blank) into the instrument and pressing the **ZERO** key.*

3.2.4 Measuring the Prepared Sample

When ready to take the reading, place the prepared sample in the sample compartment. For best results orient the sample cell consistently for each measurement; see *Figure 5* on page 19. Place the instrument cap (light shield) over the sample cell and press the **READ** key. After a brief pause, the results will be displayed.

Toggle between absorbance or percent transmittance values by successive presses of the **ABS %T** key. Press the **CONC** key to restore the concentration display. Successive presses of the **CONC**

SECTION 3, continued

key toggles between alternate forms, if any. See Appendix A for currently available chemistries and their alternate forms.

3.2.5 Alternate Chemical Forms

Many Hach programs provide alternate chemical forms for the measured parameter. Press the **CONC** key to scroll through these alternate forms after the measurement is displayed. Each press of the **CONC** key takes the user to the next alternate chemical form. For example: In Program #1, mg/L Al may also be displayed as mg/L Al₂O₃. If alternate forms are not available, the instrument returns to its original form and reading.

3.2.6 Using the Timer

Many Hach test methods use one or more timers which are pre-programmed into the DR/800 Series Colorimeters. When the procedure instructs you to, press the **TIMER** key to display a timer interval. Press **ENTER** to start the timer count-down. Several beeps will sound at the end of a timer interval. If the method requires additional timers, the instrument will automatically display the next timer when the first timer elapses. Press **ENTER** to start the next timer.

To zero the instrument on the blank while the timer is running, press the **EXIT** key. The timer icon will continue to flash, indicating the timer is running. Press **ZERO**, or perform other available functions within the method (such as blank correction) while the timer is running. To return to the timer display, press the **TIMER** key.

3.2.6.1 Using the Timer in Manual Mode

The manual timer function allows the operator to use the timer independently from the method timer. Make sure the instrument is not in numeric entry mode and activate the timer with a press of the **TIMER** key. If using a pre-programmed timer, press the **TIMER** key again.

The “#” action icon is illuminated, to indicate that the numeric keypad is active. Enter the desired time using the numeric keypad. For example, to enter 2 minutes, press **2 0 0**, then **ENTER**. To enter 12 minutes, press **1 2 0 0**, then **ENTER**. The display will momentarily show the entered time, then the timer countdown

SECTION 3, continued

will begin. The display will show the remaining time. At the end of the elapsed time, the instrument sounds five beeps.

3.2.6.2 Stopping the Timer

Stop the timer at any point in the countdown by pressing the **ENTER** key. If a pre-programmed timer was in use, the full timer period will be displayed. Press the **ENTER** key again to resume count down. If a manual timer was in use, the display for entering a new length of time will be shown, see Section 3.2.6.1 *Using the Timer in Manual Mode*. Press **EXIT** to leave the timer mode.

3.3 Reagent Blank Correction

The Reagent Blank Correction can be used with some of the factory-entered methods. It subtracts the color absorbed when running the test with deionized water instead of sample. The blank value is subtracted from every result to correct for any background color due to reagents.

When using the Reagent Blank Correction feature, the blank correction should be entered before the Standard Adjust feature is used.

To enter a programmed correction for the reagent blank:

1. Run the test using deionized water with each new lot of reagents.
2. Press **READ** to obtain the blank value; record the value for use in step 4..
3. Press **SETUP**, scroll to **BLANK** and press **ENTER**. The display will show **BLANK?**.
4. Enter the blank value obtained in step 2..
5. Press **ENTER** to accept the value as the blank to be subtracted from each reading.
6. The display will show 0.00 mg/L (resolution and units vary with the method) and the sample cell icon will be displayed, indicating that the reagent blank feature is enabled and the blank value will be subtracted from each reading. Repeat the reagent blank adjust for each new lot of reagents.

SECTION 3, continued

Note: After entering a reagent blank adjust, the display may flash "limit" when zeroing if the sample used for zeroing has a lower absorbance value than the reagent blank.

To disable the Reagent Blank adjust feature, press **SETUP**, scroll to **BLANK** and press **ENTER** twice. The concentration readings will be displayed without subtracting the blank. The sample cell icon will no longer appear in the display.

Do not attempt to use the Reagent Blank Adjust feature if the procedure uses a reagent blank for zeroing.

3.4 Adjusting the Standard Curve

The DR/890 Colorimeter has over 90 Hach Programs permanently installed in memory (other models have fewer programs). A program usually includes a preprogrammed calibration curve. Each curve is the result of an extensive calibration performed under ideal conditions and is normally adequate for most testing. Deviations from the curve can occur from using compromised testing reagents, defective sample cells, incorrect test procedure, incorrect technique, or other correctable causes. Interfering substances or other causes may be beyond the analyst's control.

In some situations, using the preprogrammed curve may not be convenient:

- Running tests where frequent calibration curve checks are required.
- Testing samples which give a consistent test interference.

Consider the following before adjusting the calibration curve:

1. Will future test results be improved by adjusting the curve?
2. Are interfering substances consistent in all the samples that you will test?

Any precision and test range information provided with the procedure may not apply to an adjusted curve calibration.

You can adjust many of the calibration curves by following the steps found in the test procedures. Working carefully is

SECTION 3, continued

important. After the adjustment, it is wise to run standard solutions of several concentrations to make sure the adjusted curve is satisfactory. Perform standard additions on typical samples to help determine if the adjusted curve is acceptable.

Think of the standard adjust measurement as a two-step process. First, the instrument measures the sample using the preprogrammed calibration. Second, it multiplies this measurement by an adjustment factor. The factor is the same for all concentrations. The instrument will remember the factor indefinitely and will display the standard adjustment icon when it is used.

Adjust the calibration curve using the reading obtained with a Hach Standard Solution or carefully prepared standard made from a concentrated Hach Standard Solution. It is important to adjust the curve in the correct concentration range. For most purposes, Hach recommends adjusting the curve using a standard concentration that is 70 to 85% of the maximum concentration range of the test.

For example, the Hach preprogrammed method for fluoride has a range of 0-2.0 mg/L F. To adjust the calibration curve, use a standard with a concentration between 1.4-1.6 mg/L. Hach provides a 1.60 mg/L Fluoride Standard Solution (75% of the full range). This is a convenient standard to use for adjusting the calibration curve.

If the range of all your samples is known to be below a concentration that is less than 50% of the full range (50% of 2.0 is 1.0 mg/L), then adjust the standard curve with a standard that is within that range.

For example, if all the samples contain 0.6-0.9 mg/L F, you may use a 1.00 mg/L fluoride standard to adjust the curve. You may use the 1.00 mg/L standard because it is closer to the sample range you are working with.

If you are using a Reagent Blank Correction, the blank correction should be entered before the standard curve is adjusted.

To adjust the standard curve:

SECTION 3, continued

1. Prepare the standard.
2. Use the standard as the sample in the procedure.
3. When the reading for the standard is obtained, press **SETUP**.
4. Use the **ARROW** keys to scroll to the “**STD**” setup option.
5. Press **ENTER** to activate the standard adjust option.
6. Enter the concentration of the standard used.
7. Press **ENTER**. The standard adjust icon will be displayed, indicating that the curve has been adjusted with the standard.

***Note:** If the attempted correction is outside the allowable adjustment limit, the instrument will beep and flash the error icon and the operation will not be allowed.*

To eliminate the standard curve adjustment:

1. Press the **PRGM** key.
2. Enter the stored-program number and press **ENTER**.
3. Press the **SETUP** key
4. Press an **ARROW** key to display **STD**.

***Note:** On will be displayed if an adjustment is in use.*

5. Press **ENTER** twice.

3.5 Using a Programmed Method

Hach programmed and user-entered program options are available on this instrument. The Procedures Manual supplied at the time of purchase contains all currently available Hach-programmed methods. Up to ten user-programmed methods may be entered into the instrument. See *Creating a New User-entered Program* on page 33 for instructions for this function. *Table 3* shows the components of typical factory programmed test method.

SECTION 3, continued

Table 3

Step	Action/Keystroke	Display
1. Turn power on.	Press the EXIT/I/O key.	The instrument defaults to and displays the initial screen of the last program used. EXAMPLE: If program 20 was the last program in use, the instrument will automatically recall program 20.
2. Select the Program number to be used.	Press the PGRM key, then enter the program number and press the ENTER key.	After the PGRM key is pressed, a blinking cursor appears with a question mark. Enter the desired program number. Press ENTER to confirm this action and recall the desired program number.
3. As needed, set, then start the TIMER .	Press the TIMER key. In a Hach-stored program, the timer automatically defaults to the appropriate reaction time. Press ENTER to start the timer.	The entered or programmed reaction time will display and count down to zero.
4. ZERO the instrument using the sample blank.	Insert blank and press ZERO .	After the ZERO key is pressed, the instrument zeros on the sample cell.
5. Obtain reading in concentration, absorbance, or % transmittance.	Place the prepared sample into the cell holder. Press READ .	The instrument reads the sample and displays the results.

3.6 Quality Assurance

Verify the performance of your instrument in seconds using Hach DR/Check™ ABS Secondary Standards (Cat. No. 27639-00). These gel standards provide a measure of instrument absorbance for use anywhere, anytime, as often as laboratory quality assurance procedures suggest. The kit includes a blank and one standard each of a low-, mid-, and high range absorbance value from 0 to 2 ABS, for use with any DR/800 Series Colorimeter.



DANGER
This instrument is not intended for use with flammable samples or those containing hydrocarbons.

PELIGRO

Este instrumento no está destinado para uso con muestras inflamables o que contengan hidrocarburos.

PERIGO

Este instrumento não é feito com o fim de ser empregado com amostras inflamáveis ou aquelas que contêm hidrocarbonetos.

DANGER

Cet instrument n'est pas conçu pour une utilisation avec des échantillons inflammables ou des échantillons contenant des hydrocarbures.

GEFAHR

Dieses Gerät darf nicht für Tests mit brennbaren Proben oder Proben, die Kohlenwasserstoffe enthalten, benutzt werden.

The DR/800 Series Colorimeters can store the calibration information needed to read prepared samples from up to ten different user-entered programs. To create a new, user-entered program, you will need a blank and prepared standards or the correct absorbance readings for each standard. The prepared standards are made with standard solutions of the parameter (i.e. analyte). Up to twelve concentrations of standards, including a zero concentration standard, may be used.

The absorbances of the prepared standards must be different from one another. If the colorimeter detects a duplicate, it will beep and ignore the latest reading.

Using a previously entered method's program number erases all the previously entered information stored under that program number.

While creating a user-entered program, the colorimeter remains on for four hours following any keypress. If more than four hours pass between keypresses, the instrument will power down. All data which was entered, but not yet stored, will be deleted. The user-entered program must be re-entered from the beginning.

4.1 User-Entered Programs

The instrument allows storage of up to ten user-entered programs (101–110) and up to 113 Hach programs. A minimum of two data points are required for the instrument to recognize and accept a user-entered program.

- Program numbers 101 through 110 are reserved for storing user-entered programs.
- The maximum number of data points that can be entered for a method is 12. After the twelfth standard (1 through 12) is accepted, the instrument stores the method and will not accept any more data, but will allow the user to review the data already entered.

Before entering a calibration, determine the optimum wavelength, timing sequences (if any), and the workable range of the method.

4.2 Calibration Curves

Calibration curves may have positive or negative slopes, but they must be based on absorbance (% transmittance not allowed) and must pass through the origin that represents zero concentration.

It is important that the standards adequately describe the curve over the range of interest. Because this is largely dependent on the shape of the curve, it may be necessary to prepare a preliminary curve using extra data points to help select the appropriate standards.

If the curve is linear, only two concentration data points are needed. For example, standards with a zero absorbance and a standard with 1.000 absorbance are appropriate. If the curve is nonlinear, additional data points are needed to achieve good accuracy. Up to 12 data points can be entered for a single calibration curve.

4.3 User-entered Program Information for Bleaching Chemistries

Although the majority of colorimetric test procedures produce a higher absorbance (i.e. deeper color) as the concentration of the parameter being measured increases, some tests do the opposite. These bleaching chemistries (fluoride is one example) produce a

SECTION 4, continued

lighter color at increasing concentrations. The zero concentration standard is usually produced by combining deionized water with the reagents. Commonly this solution is used to zero the instrument as in *Step 14 of Section 4.4 Creating a New User-entered Program*.

Once the zero is entered, the prepared standards must be read from lightest to darkest. In the case of bleaching chemistries, the absorbance values reported by the colorimeter may be negative.

Even when your test produces a lower absorbance (lighter color) with increasing concentration, the prepared standards must be read by the colorimeter in the order of increasing absorbance (i.e., from colorless or the palest color, to the deepest color). The instrument will not accept standards read out of order.

4.4 Creating a New User-entered Program

Use the step-by-step instructions below to enter a new user-entered program into instrument memory. Terminate at any point (before the program is stored) by pressing the **EXIT** key until the display is blank. The colorimeter will not retain any of the entered data.

1. Press the **I/O** key to turn on the instrument.
2. Press the **SETUP** key. The display will show **SETUP** in the upper-left and the down-arrow icon in the lower-right. Available action functions are also shown.
3. Press the down **ARROW** key until **USER** is displayed.
4. Press the up **ARROW** key if the display goes past **USER**.
5. Press the **ENTER** key. Four horizontal lines (numeric entry display) will be displayed.
6. Select a program number from 101 through 110 by pressing the corresponding digit key. The number will appear in the display.

Note: Press **CE** to correct errors.

7. Press **ENTER**. A wavelength and **nm** will be displayed.

SECTION 4, continued

- If the wavelength is correct as displayed, skip to Step *step 8*.
 - Some instrument models can use different wavelengths. If a different wavelength is preferred, proceed as follows:
 - a. Press **ENTER**. A flashing question mark will be displayed in the lower-right corner.
 - b. Press either **ARROW** key until the preferred wavelength is displayed.
 - c. Press **ENTER** to accept the displayed wavelength. The down-arrow icon will be displayed.
8. Press the down **ARROW** key to move to the **RES** (resolution) option. One to four zeros, a decimal point if needed, and the units of concentration may be modified here.
- If the displayed resolution and units are correct, skip to step *step 9*.
 - If the displayed resolution or units are incorrect for your test, proceed with the following:
 - a. Press **ENTER**. A flashing question mark will be displayed.
 - b. Press either **ARROW** key until the preferred resolution and concentration units are displayed. The available options are:

0.000	0.00	0.0	0
0.000 µg/L	0.00 µg/L	0.0 µg/L	0 µg/L
0.000 mg/L	0.00 mg/L	0.0 mg/L	0 mg/L
0.000 g/L	0.00 g/L	0.0 g/L	0 g/L
 - c. Press **ENTER**. The question mark will disappear.
9. Press the down **ARROW** key to scroll to **STD**. **STD** and the number of the standard (i.e., 1 is shown for the first standard, 2 for the second, etc.) will be shown on the lower portion of the display.

SECTION 4, continued

10. Press **ENTER**. Four horizontal lines (denoting numeric entry) will be displayed.

11. Enter the standard's concentration, using the numeric entry keys (the # icon will be illuminated on the display).

*Note: Press the **CE** key to correct errors.*

12. Press the **ENTER** key. The concentration will be displayed.

Note: A beep means that the concentration is a duplicate of a previous standard or the concentration is too high for the selected resolution. Repeat step step 11 with a different concentration and continue.

13. Press the down **ARROW** key. **ABS** will be displayed followed by the number of the standard.

14. The colorimeter requires one zero be entered in this procedure; the **ZERO** action icon will appear in the lower portion of the display. Place a blank into the cell holder and press the **ZERO** key. Four horizontal lines will appear, then disappear, across the display. The **READ** action icon will appear in the lower portion of the display.

Note: If necessary, the colorimeter can be re-zeroed. The most recently entered zero will be used for subsequent readings.

15. Prepare the standards using the same reagents and procedure used to test samples.

16. Place the prepared standard into the cell holder.

17. Press the **READ** key. An absorbance value will be displayed.

*Note: Or, press the **ENTER** key to input an absorbance value or change the value read by the instrument. Use the numeric keys to enter the value then press the **ENTER** key.*

*Note: A beep indicates that the absorbance is a duplicate of a previously entered standard or that it falls between two previous standards. Repeat steps step 15 through 17. with the correct standard, or press the up **ARROW** key and repeat steps 9. through 17. with a correct, prepared standard and blank.*

18. Press the down **ARROW** key to advance to the next standard.

19. Repeat *step 9* through *step 18* for all remaining standards.

20. Press the **EXIT** key once. **STORE ?** will be displayed.

21. Press the **ENTER** key to store the new method in the instrument's memory.

4.5 Reviewing and Editing User-Entered Programs

Note: When a user-entered program is edited and stored, all stored data associated with that program is erased.

All method information previously stored by the operator can be reviewed and changed to add, delete, or modify data points. At any point during the editing function, the operator can terminate the procedure and exit by pressing the **EXIT** key. No changes to the program will occur.

Because the standards must be read in the order of increasing absorbancy, data points may not be inserted into the middle of an existing user-entered program.

To review and edit previously stored user-entered programs:

1. Press the **I/O** key to turn the instrument on.
2. Press the **SETUP** key.
3. Scroll to the **USER** option and press **ENTER**.
4. Enter the program number of the method to review or edit and press the **ENTER** key.
5. Scroll through the calibration information using the **ARROW** keys. To avoid making changes, press the **EXIT** key.
6. To edit the data shown on the display, press **ENTER**. Make necessary changes, then press the **ENTER** key to return to reviewing the data.
7. Press **EXIT** once. **STORE?** will be displayed.
8. Press **ENTER** to store the program.

4.6 Erasing User-entered Programs

Note: *When a user-entered program is erased, all stored data associated with that program is also erased.*

User-entered programs are automatically deleted when another user-entered program is entered and stored in the previously entered method's storage number (101–110). They also may be erased from the instrument memory as follows:

1. Press the **I/O** key to turn the instrument on.
2. Press the **SETUP** key.
3. Scroll to the **USER** option and press **ENTER**.
4. Enter the program number of the method to be erased and then press **ENTER**.
5. Scroll to the concentration data for STD 1 using the down **ARROW** key. Press **ENTER**.
6. Press **CE**. Press **ENTER**.
7. Press the **EXIT** key. **ERASE?** will be displayed.
8. Press the **ENTER** key to erase the method or the **EXIT** key to retain it in memory.

To store sample data, press **STORE** after the sample measurement is displayed. Data must be stored if you wish to recall it later for review, downloading or printing. The following information is stored for each sample:

- instrument model
- instrument serial number
- chemical form
- concentration
- units
- absorbance
- %T
- date
- time
- sample number
- program number

After the **STORE** key is pressed, a flashing question mark icon is shown in the lower-right portion of the display. In the center of the display, the next available storage number will appear. If this storage location is acceptable, press **ENTER** to accept it.

To select an empty storage number (between 1 and 99), use the **ARROW** keys to scroll to the desired number or enter the desired number with the numeric keys. Press **ENTER** to accept. The instrument will store the data, then revert back to the measurement display.

5.1 Recalling Data

To recall data stored in the colorimeter, press the **RECALL** key.

Use the **ARROW** keys to scroll through the stored data. Only data numbers containing stored sample reading data (of the available storage numbers 1-99) are displayed in the **RECALL** menu. For

SECTION 5, continued

example, if the user has stored data into storage numbers 6, 10 and 15, those are the only accessible numbers in the Recall option. Available storage numbers are not shown as a Recall option because no data has been stored for recall purposes.

When a number of sample readings have been stored and a specific reading must be recalled, proceed as follows:

1. Press the **I/O** key to turn the colorimeter on.
2. Press the **RECALL** key to access the **RECALL** Menu.
3. A beep indicates that no data is presently stored.
4. Press the number key(s) or either **ARROW** key on the keypad to scroll to the desired sample number.
5. Press the **ENTER** key. The stored reading will be displayed.
6. A beep indicates that no data is stored as that sample number.
7. While the stored reading is displayed, press the **DATE** key or the **TIME** key to display the date or time the reading was stored. Press the **CONC** key to display the concentration data.
8. If other stored data is desired, press either **ARROW** key until the data is displayed.
9. Press **EXIT** to terminate data recall.

5.2 Erasing All Stored Data

Stored data can be erased and the memory of the instrument cleared using the procedure that follows.

1. Press the **I/O** key to turn the colorimeter on.
2. Press the **SETUP** key to enter the **SETUP** menu.
3. Scroll using the down **ARROW** key until **ERASE** and **ALL** appears on the display.
4. Press the **ENTER** key to confirm this selection with the instrument.

SECTION 5, continued

A flashing question mark icon will appear in the lower-right portion of the screen as an additional step to avoid erasing all data if the choice was made erroneously.

5. Confirm this action by pressing the **ENTER** key or, if this is not the desired action, press the **EXIT** key.

After the **ENTER** key is pressed, the instrument automatically erases all stored data and returns to the last used program.

6.1 Data Transfer Adapter Basics

The optional Data Transfer Adapter (DTA) utilizes infra-red technology to receive data from the DR/800 Series Colorimeter and then transfer the signal into RS232 format. The DTA then sends the RS232 signal to a printer or personal computer.

The sleeve design makes the adapter compact, easy to use, and robust. Samples may be tested while the adapter is in place and the information may be immediately printed or downloaded to a computer. Data stored in the instrument memory may also be printed or downloaded at any time.

6.1.1 Attaching the Data Transfer Adapter

The Data Transfer Adapter is designed to fit on the instrument in the same way the instrument cap does. To install the DTA, simply remove the instrument cap, then slide the DTA onto the colorimeter body until it snaps into place. The DTA design allows the instrument cap to be used as a light shield. See *Figure 8 Installing the Data Transfer Adapter*.

Figure 8 **Installing the Data Transfer Adapter**

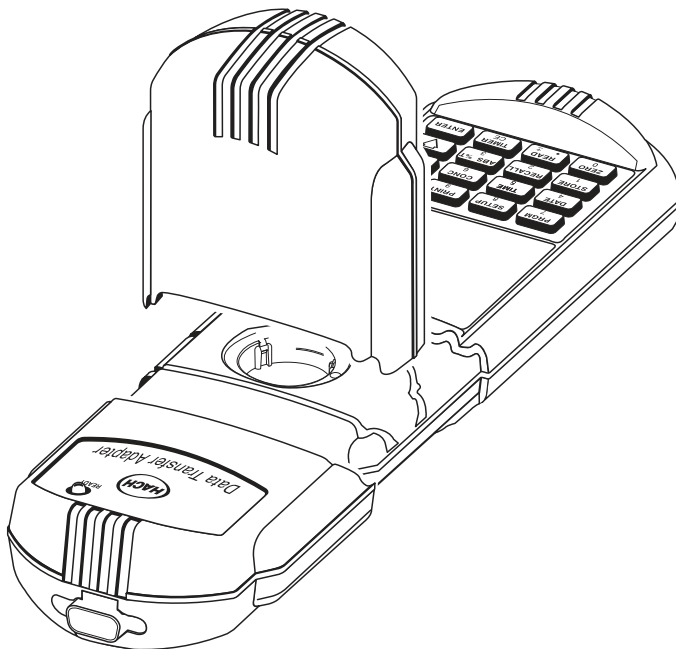

6.2 RS232 Connections

The RS232 receptacle on the Data Transfer Adapter connects with a 9-pin Sub-D connector (see *Figure 9 RS232 Connection*). A suitable RS232 cable is listed under Optional Accessories in *REPLACEMENT PARTS AND ACCESSORIES* on page 57.

The RS232 interface output is an eight-bit data word plus one stop bit and no parity with a baud rate of 1200. It can communicate with either a serial printer or a serial communication port on a computer.

Press the **PRINT** key to send data to the printer or computer. See Section 6.3 *Sending Data to a Printer or Computer* for instructions.

With the use of a serial-to-parallel converter, the data string transmitted from the colorimeter prints on any compatible parallel printer of the type normally used with IBM compatible applications.

All RS232 connections are made using the serial I/O port on the DTA. This port uses an industry standard 9-pin connector. See *Figure 9 RS232 Connection*.

Figure 9 RS232 Connection

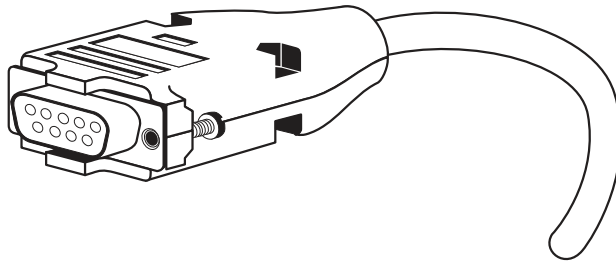

Note: For optimum performance and ESD protection, use a five-conductor shielded cable. Use a metal shell for the printer or CRT terminal connector, and connect the shield of the cable to the metal shell and to the sleeve (signal ground) of the RS232 plug.

SECTION 6, continued

6.2.1 Setup and Use of the Printer

Follow the manufacturer's instructions when configuring the printer for compatibility with the colorimeter.

Pressing **PRINT** manually starts the printing, and pressing the **EXIT** key stops the printing (refer to Section 6.3 *Sending Data to a Printer or Computer*).

Connect the DTA to a printer using an appropriate cable.

Table 4 and *Table 5* show the proper pin connections for 9-pin computer cables and for 25-pin printer cables. Use of cables that do not match the pin information given may cause undesirable operation.

Table 4 Standard 9-pin to 9-pin Computer Cable

DR/800 Series 9-pin Connector Socket		Computer 9-pin D Connector, plug	
Pin	Signal Name	Pin	Signal Name
2	RXD	3	TXD
3	TXD	2	RXD
4	DTR	no connection	—
5	GND	5	GND
6	DSR	no connection	—
7	RTS	8	CTS
8	CTS	7	RTS

Table 5 Standard 9-pin to 25-pin Printer Cable

DR/800 Series 9-pin Connector Socket		Computer 9-pin D Connector, plug	
Pin	Signal Name	Pin	Signal Name
2	RXD	no connection	—
3	TXD	3	RXD
4	DTR	no connection	—
5	GND	7	GND
6	DSR	20	DTR
7	RTS	no connection	—

SECTION 6, continued

Table 5 Standard 9-pin to 25-pin Printer Cable

DR/800 Series 9-pin Connector Socket		Computer 9-pin D Connector, plug	
Pin	Signal Name	Pin	Signal Name
8	CTS	20	DTR

To print, the communication parameters (baud rate, data bits and parity) of the instrument and the printer must match.

6.2.2 Connecting to a Personal Computer

Connect the colorimeter to a personal computer (PC) with the computer interface cable (Cat. No. 48129-00) listed under *REPLACEMENT PARTS AND ACCESSORIES* on page 57. The cable provides a direct link between the colorimeter and the 9-pin D connector used for the serial port on most personal computers. If your computer has a 25-pin D connector, use a 9-pin to 25-pin adapter (available at most computer supply stores).

Use a communications software, such as HachLink™ Software (Cat. No. 49665-00) to collect data from the instrument. HachLink is a Windows-based application that allows a personal computer to capture data from several Hach instruments, including the DR/800 Series Colorimeters.

The captured data can be stored in a text file as a spread-sheet compatible format or as free-format text. Data captured in the spreadsheet format is easily transferred into most spreadsheet programs (i.e., Excel®, Microsoft Works®, Lotus 123®) for graphing and reporting.

To install and run HachLink™ Software, the computer and software must meet the following minimum requirements:

- PC with a 486/100 MHz or higher processor
- 32 MB RAM
- Hard drive with at least 20 MB free space
- 3½ inch floppy disk drive or CD-ROM drive
- VGA graphics with 640 x 480 or higher resolution, 256 colors

SECTION 6, continued

- Mouse or other pointing device
- 9-pin serial port (or 25-pin serial port with 9-pin adapter)
- Windows 95, 98, 2000, or NT 4.0 operating system

To transfer data, the communication parameters (baud rate, data bits and parity) of the instrument and the computer must match. Once the communication link is established, press **PRINT** to send data to the computer.

6.3 Sending Data to a Printer or Computer

A permanent record of test results may be obtained using the DTA RS232 serial output to drive a printer or by transferring the data to a computer for storage. Data displayed on the instrument screen may be sent to an accessory printer or computer by attaching the DTA to the instrument and pressing the **PRINT** key. The data can be recalled from memory or the current sample reading. Only the information shown on the display will be printed.

6.3.1 Sending Currently Displayed Data

To transfer currently displayed data:

1. Remove the instrument cap and slide the DTA onto the instrument until snug.
2. Make sure the DTA is properly connected to the computer or printer. See *Section 6.2 RS232 Connections*.
3. Press the **PRINT** key. Four dashes and **PRINT** are displayed while the data is being transmitted to the DTA.

SECTION 6, continued

6.3.2 Sending Recalled Data

To transfer recalled data:

1. Remove the instrument cap and slide the DTA onto the instrument until snug.
2. Make sure the DTA is properly connected to the computer or printer. (See *Section 6.2 RS232 Connections*.)
3. Recall the data to be transferred (see *Section 5.1 Recalling Data* on page 39).
4. When sample data is displayed, press the **PRINT** key. Four horizontal lines and **PRINT** are displayed while the data is transmitted to the DTA.

6.3.3 Sending All Stored Data

All data stored in memory may be sent to a printer or computer via the **SETUP** menu option as follows:

1. Remove the instrument cap and slide the DTA onto the instrument until snug.
2. Make sure the DTA is properly connected to the computer or printer. (See *Section 6.2 RS232 Connections*.)
3. Press the **SETUP** key.
4. Scroll, using the down **ARROW** key, to the **PRINT** option.
5. Press the **ENTER** key when the word **ALL** is displayed above **PRINT**. All stored data is now sent to the DTA. After the data has been successfully sent, the instrument defaults to the last used program.

Transferred data will include the following information:

- instrument model number
- instrument serial number
- instrument software version
- date

SECTION 6, continued

- time
- program number
- sample number
- concentration
- units
- chemical form
- Overrange errors (limit)
- absorbance
- %T

Figure 10 Printed Data Format

```
DR/890      970990000319  P1.2
01/01/97   00:02  Program 52
0.000 ABS  100.1  %T

DR/890      970990000319  P1.2
02/01/97   19:19  Program 56
0.451 ABS  35.40  %T

DR/890      970990000319  P1.2
02/02/97   01:14  Program 25
0 520 ug/L DEHA
0.000 ABS  99.89  %T
```

7.1 Cleaning the Colorimeter

Use a damp cloth to wipe the outside of the colorimeter enclosure. Wipe up spills promptly. Use cotton swabs to clean and dry the sample compartment if any spillage occurs.

Keep the colorimeter and sample cells clean at all times. Use a lens tissue or a soft, lint-free cloth (that will not leave an oil film) to wipe out the sample cell.

7.1.1 Cleaning the Data Transfer Adapter

Little cleaning is required of this adapter. Clean the outside and inside with a barely damp cloth. Wipe up spills promptly.

7.1.2 Sample Cells

Clean sample cells with detergent, rinse several times with tap water, and then rinse thoroughly with deionized water. Some cells may require acid washing or other special cleaning procedures. Refer to the Procedures Manual for additional information. Rinse sample cells used with organic solvents (chloroform, benzene, toluene, etc.) with acetone before the detergent wash, and again as a final rinse before drying.

7.2 Replacement Instructions

To prevent static electricity damage to the instrument, always turn the instrument off before removing the batteries.

7.2.1 Battery Replacement

When the **LOW BATTERY** icon appears in the display the batteries must be replaced or recharged as soon as possible to ensure proper instrument performance. Turn the instrument off before removing the battery compartment door.

The correct date and time may need to be reentered after battery replacement. See *Section 2.3 Setting the Date and Time*.

See *Section 2.1 Battery Installation* for complete installation instructions.

8.1 Introduction

Correcting problem conditions with the DR/800 Series Colorimeters in the field is limited to responding to the error messages presented in the display. Other problems must be handled by a Hach technician at a service center. Refer to *REPAIR SERVICE*. **Do not** attempt to service anything other than the battery; there are no other field-serviceable parts. Opening the instrument case will void the warranty.

8.1.1 Error Codes

This feature identifies the problem area or areas when an error indication occurs during instrument operation. When an error occurs, **ERROR** displays on the screen, followed by a number which refers to a diagnostic error code. Refer to *Table 6* below to determine the error cause and possible corrective actions. Turn the instrument off, then on, to restore the instrument to operation.

Table 6 Error Codes

ERROR Code Number	Error Code Type	Corrective Action
1	Unconfigured instrument	Contact Hach Instrument Service Department
2	Could not read program data	Contact Hach Instrument Service Department
3	Could not write program data	Contact Hach Instrument Service Department
4	Measurement battery error	Replace instrument batteries
5	Measurement A/D error	Contact Hach Instrument Service Department
6	Measurement offset error	Check to be sure instrument light shield (cap) is correctly installed
7	Measurement low light error	Check for light path blockage Zero is out of instrument range; dilute to within range Contact Hach Instrument Service Department
8	Measurement over-range error	Make sure instrument cap is properly installed Contact Hach Instrument Service Department

SECTION 8, continued

8.1.2 Beeper/Error Icon

When a key is pressed that calls for the instrument to perform a function that is not available at that time, the beeper is activated once and the error icon appears on the display. Each time the unacceptable command is entered, one beep sounds.

If an unavailable program number is entered, the beeper also sounds. Program numbers must range from 101 to 110 (user programs) and 1 to 100 (Hach programs). Entering a number other than these results in the beeper sound and the error icon briefly illuminates. After this beep sounds, re-enter the proper number.

8.1.3 Concentration Out of Range

An out-of-range condition is indicated by the illuminated **LIMIT** icon. It means the sample concentration exceeds the range of the programmed calibration. Make sure the test procedure is followed correctly, dilute the sample (for over range samples) and rerun the test. Each Hach test has an upper concentration value that defines the program range. Measurements beyond that range are unreliable.

8.1.4 Low Battery

The instrument continuously monitors battery voltage. If the battery voltage falls to a level which indicates less than ten percent battery life remains, the instrument automatically warns the operator by displaying the **LOW BATTERY** icon. Replace the batteries as soon as possible for most reliable instrument performance.



GENERAL INFORMATION

At Hach Company, customer service is an important part of every product we make.

With that in mind, we have compiled the following information for your convenience.

REPLACEMENT PARTS AND ACCESSORIES

REQUIRED APPARATUS

Description	Unit	Cat. No.
Adapter, Assembly, COD	each	4846400
Batteries, Alkaline AA	pkg/4	1938004
Manual Set, DR/890, includes Instrument & Procedure Manual & Binder	each	4847077
Manual Set, DR/850, includes Instrument & Procedure Manual & Binder	each	4845077
Manual Set, DR/820, includes Instrument & Procedure Manual & Binder	each	4844077
Sample Cell, 25 x 95 mm 10-20-25 mL.....	pkg/6	2401906
Sample Cell, 1 cm/10 mL, pk/2.....	pkg/2	4864302

OPTIONAL ACCESSORIES

Adapter, Data Transfer, RS232, includes 48129-00 cable	each	4849000
Cap, Sample Cell, for 25 x 95 mL cell.....	pkg/12	2401812
Carrying Case, DR/800 Series Colorimeter, hard-sided	each	4942500
Carrying Case, DR/800 Series Colorimeter, soft-sided w/shoulder strap	each	2722000
Carrying Case, Portable Laboratory	each	4943000
Computer Interface Cable, 6 ft., for use with the DTA	each	4812900
DR/Check™ ABS Standards.....	set	2763900
HachLink Software	each	4966500
Instrument Cap	each	4943100

How To Order

By Telephone:

6:30 a.m. to 5:00 p.m. MST
Monday through Friday
(800) 227-HACH
(800-227-4224)

By FAX: (970) 669-2932

By Mail:

Hach Company
P.O. Box 389
Loveland, CO 80539-0389
U.S.A.

Ordering information by E-mail: orders@hach.com

Information Required

- Hach account number (if available)
- Your name and phone number
- Purchase order number
- Brief description or model number
- Billing address
- Shipping address
- Catalog number
- Quantity

Technical and Customer Service (U.S.A. only)

Hach Technical and Customer Service Department personnel are eager to answer questions about our products and their use. Specialists in analytical methods, they are happy to put their talents to work for you.

Call **1-800-227-4224** or E-mail techhelp@hach.com.

International Customers

Hach maintains a worldwide network of dealers and distributors. To locate the representative nearest you, send E-mail to intl@hach.com or contact:

In Canada, Latin America, Africa, Asia, Pacific Rim:

Telephone: (970) 669-3050; FAX: (970) 669-2932

In Europe, the Middle East, or Mediterranean Africa:

HACH Company, c/o
Dr. Bruno Lange GmbH
Willstätterstr. 11
D-40549 Düsseldorf
Germany
Telephone: +49/[0]211.52.88.0
Fax: +49/[0]211.52.88.231

Repair Service

Authorization must be obtained from Hach Company before sending any items for repair. Please contact the HACH Service Center serving your location.

In the United States:

Hach Company
100 Dayton Avenue
Ames, Iowa 50010
(800) 227-4224 (U.S.A. only)
Telephone: (515) 232-2533
FAX: (515) 232-1276

In Canada:

Hach Sales & Service Canada Ltd.
1313 Border Street, Unit 34
Winnipeg, Manitoba
R3H 0X4
(800) 665-7635 (Canada only)
Telephone: (204) 632-5598
FAX: (204) 694-5134
E-mail: canada@hach.com

In Latin America, the Caribbean, the Far East, the Indian Subcontinent, Africa, Europe, or the Middle East:

Hach Company World Headquarters
P.O. Box 389
Loveland, Colorado, 80539-0389
U.S.A.
Telephone: (970) 669-3050
FAX: (970) 669-2932
E-mail: intl@hach.com

Warranty

Hach Company warrants this product to the original purchaser against any defects that are due to faulty material or workmanship for a period of **one year from date of shipment**.

In the event that a defect is discovered during the warranty period, Hach Company agrees that, at its option, it will repair or replace the defective product or refund the purchase price, excluding original shipping and handling charges. Any product repaired or replaced under this warranty will be warranted only for the remainder of the original product warranty period.

This warranty does not apply to consumable products such as chemical reagents; or consumable components of a product, such as, but not limited to, lamps and tubing.

Contact Hach Company or your distributor to initiate warranty support. Products may not be returned without authorization from Hach Company.

Limitations

This warranty does not cover:

- damage caused by acts of God, natural disaster, labor unrest, acts of war (declared or undeclared), terrorism, civil strife or acts of any governmental jurisdiction
- damage caused by misuse, neglect, accident or improper application or installation
- damage caused by any repair or attempted repair not authorized by Hach Company
- any product not used in accordance with the instructions furnished by Hach Company
- freight charges to return merchandise to Hach Company
- freight charges on expedited or express shipment of warranted parts or product
- travel fees associated with on-site warranty repair

This warranty contains the sole express warranty made by Hach Company in connection with its products. All implied warranties, including without limitation, the warranties of merchantability and fitness for a particular purpose, are expressly disclaimed.

Some states within the United States do not allow the disclaimer of implied warranties and if this is true in your state the above limitation may not apply to you. This warranty gives you specific rights, and you may also have other rights that vary from state to state.

This warranty constitutes the final, complete, and exclusive statement of warranty terms and no person is authorized to make any other warranties or representations on behalf of Hach Company.

Limitation of Remedies

The remedies of repair, replacement or refund of purchase price as stated above are the exclusive remedies for the breach of this warranty. On the basis of strict liability or under any other legal theory, in no event shall Hach Company be liable for any incidental or consequential damages of any kind for breach of warranty or negligence.

CERTIFICATION

Hach Company certifies this instrument was tested thoroughly, inspected and found to meet its published specifications when it was shipped from the factory.

The DR/800 Series Colorimeter has been tested and is certified as indicated to the following instrumentation standards:

EN 60825-1: LEDs used in this product are Class 1

Immunity:

EN 50082-1 “1997”(Generic Immunity Standard) per **89/336/EEC EMC:** Supporting test records by Hach Company, certified compliance by Hach Company.

Required Standard/s include:

EN 61000-4-2 (IEC 1000-4-2) Electro-Static Discharge

EN 61000-4-3 (IEC 1000-4-3) Radiated RF Electro-Magnetic Fields

ENV 50204 Radiated Electro-Magnetic Field from Digital Telephones

Emissions:

Per **89/336/EEC EMC:** Supporting test records by Intellistor O.A.T.S., (NVLAP #0369) certified compliance by Hach Company.

Required European Standard/s include:

EN 55011 (CISPR 11) Emissions, Class B Limits

Additional Emissions Standard/s include:

CANADIAN INTERFERENCE-CAUSING EQUIPMENT REGULATION, IECS-003, Class A:

Supporting test records by Intellistor O.A.T.S., certified compliance by Hach Company.

This Class A digital apparatus meets all requirements of the Canadian Interference-Causing Equipment Regulations.

Cet appareil numérique de la classe A respecte toutes les exigences du Règlement sur le matériel brouilleur du Canada.

CERTIFICATION, continued

FCC PART 15, Class “A” Limits:

Supporting test records by Intellistor O.A.T.S., certified compliance by Hach Company.

This device complies with Part 15 of the FCC Rules. Operation is subject to the following two conditions:

(1) This device may not cause harmful interference, and (2) this device must accept any interference received, including interference that may cause undesired operation.

Changes or modifications to this unit not expressly approved by the party responsible for compliance could void the user's authority to operate the equipment.

This equipment has been tested and found to comply with the limits for a Class A digital device, pursuant to Part 15 of the FCC Rules. These limits are designed to provide reasonable protection against harmful interference when the equipment is operated in a commercial environment. This equipment generates, uses, and can radiate radio frequency energy and, if not installed and used in accordance with the instruction manual, may cause harmful interference to radio communications. Operation of this equipment in a residential area is likely to cause harmful interference, in which case the user will be required to correct the interference at his own expense. The following techniques of reducing the interference problems are applied easily.

1. Remove power from the Colorimeter by removing one of its batteries to verify that it is or is not the source of the interference.
2. Move the Colorimeter away from the device receiving the interference.
3. Reposition the receiving antenna for the device receiving the interference.
4. Try combinations of the above.



HACH COMPANY
WORLD HEADQUARTERS
P.O. Box 389
Loveland, Colorado 80539-0389
Telephone: (970) 669-3050
FAX: (970) 669-2932

FOR TECHNICAL ASSISTANCE, PRICE INFORMATION AND ORDERING:

In the U.S.A. - **Call toll-free 800-227-4224**

Outside the U.S.A. - **Contact the HACH office or distributor serving you.**

On the Worldwide Web - **www.hach.com**; E-mail - **techhelp@hach.com**
