

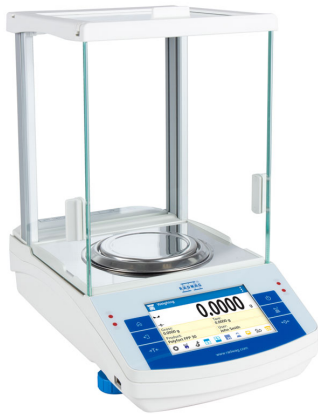

AS 520.X2 PLUS Analytical Balance





















More information on the website
radwag.com/en/info,w1,0QU



AS 520.X2 PLUS Analytical Balance

The drawings, photos and graphics used are for illustrative purposes only.

Functions

- | | | | |
|---|---|---|--|
|  Autotest |  Dosing |  Percent Weighing |  Parts counting |
|  Peak hold |  Formulation |  Newton unit measurement |  Statistics |
|  Checkweighing |  IR sensors |  Under-pan weighing |  GLP Procedures |
|  Animal weighing |  Density determination |  Ambient conditions monitoring |  Replaceable unit |
|  Statistical Quality Control |  ALIBI Memory |  Mass for titrator |  Wi-Fi |

Datasheet

AS 520.X2 PLUS Analytical Balance	
Metrological parameters	
Maximum capacity [Max]	520 g
Minimum load	-
Readability [d]	0,1 mg
Tare range	-520 g
Standard repeatability [5% Max]	0,07 mg
Standard repeatability [Max]	0,2 mg
Standard minimum weight (USP)	140 mg
Standard minimum weight (U=1%, k=2)	14 mg
Permissible repeatability [5% Max]	0,12 mg
Permissible repeatability [Max]	0,4 mg
Linearity	±0,6 mg
Stabilization time	2,5 s
Adjustment	internal (automatic)
OIML Class	I
Physical parameters	
Leveling system	semi-automatic - LevelSENSING
Display	5" graphic color touchscreen
Protection class	IP 43
Delivery components	Balance, weighing pan, weighing pan shield, bottom cover, power supply.
Weighing chamber dimensions	190×190×222 mm
Weighing pan dimensions	ø100 mm
Packaging dimensions	495×400×515 mm
Net weight	7,3 kg
Gross weight	9,3 kg
Features of use	
Database capacity	7
Touch-free operation	2 IR Sensors
Communication interface	
Communication interface	RS232 ¹ , 2×USB-A (interchangeable), USB-B, Wi-Fi, Ethernet
Electrical parameters	
Power supply	Adapter: 100 – 240V AC 50/60Hz 0,6A; 12V DC 1,2A Balance: 12 – 15V DC 0,8A max
Power consumption max.	4 W
Environmental conditions	
Operating temperature	+10 ÷ +40 °C
Ambient conditions monitoring	THBR 2.0 System, THBR BOX, THB P, THB W, THB S
Relative humidity	40% ÷ 80%

Repeatability is expressed as a standard deviation from 10 weighing cycles. Stabilization time depends on the ambient conditions and the dynamics of weighing pan loading; specified for FAST profile. 1 Barcode scanners, available as weighing instrument accessory, communicate with the instrument via RS232 interface exclusively.

* Wi-Fi® is a registered trademark of Wi-Fi® Alliance.



Accessories

Antivibration Tables
Holders for laboratory flasks
Power Adapters
Barcode scanners
Cigarette lighter receptacle power supply cables
Density determination KIT
USB cable (scale - printer)
Professional weighing table
Holders for test tubes and filters
Workstation for Pipettes Calibration
THBR 2.0 System - Ambient Conditions Monitoring

Displays
Protective cover for balances
Weighing dishes
Antistatic ionizer
Receipt Printer
RS 232, RS 485 cables
Additional modules
Under-pan weighing
RS 232 cables (scale - printer)
RS 232 – RS 485 Converter

Software

RAD-KEY
THB-R
R-LAB
E2R System

LabVIEW Driver
Alibi Reader
RADWAG Development Studio
R.Barcode

Device dimensions

AS 520.X2 PLUS Analytical Balance

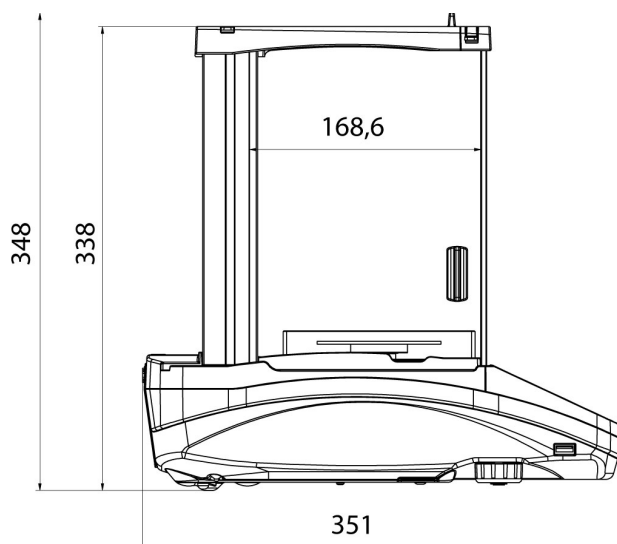
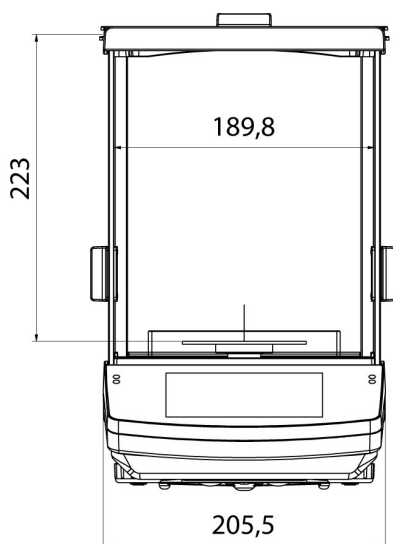

AS X2 PLUS, d = 0.01 mg

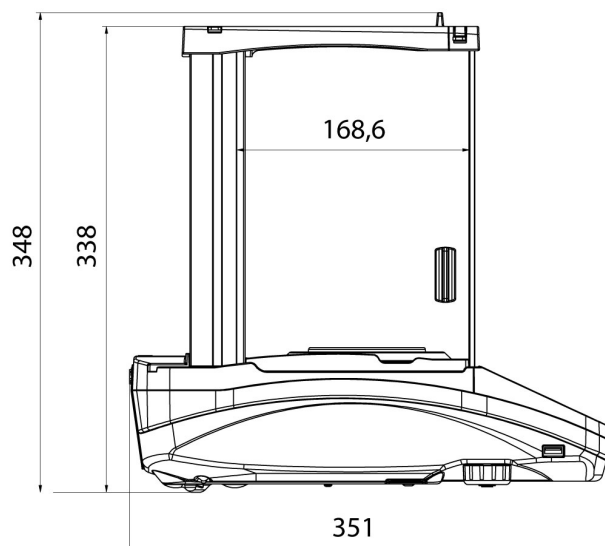
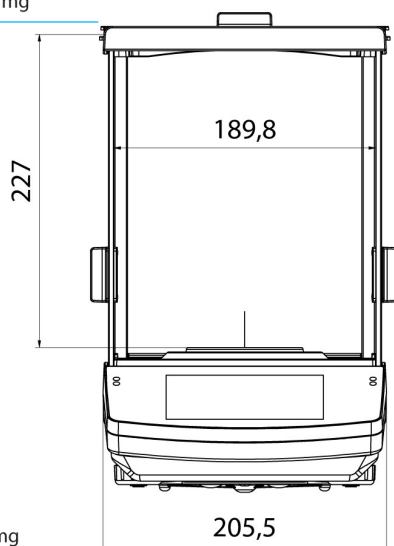

AS X2 PLUS, d = 0.1 mg