

# photoLab<sup>®</sup> 7600 UV-VIS

SPECTROPHOTOMETER



a xylem brand



The most current version of the present operating manual is available on the Internet at [www.WTW.com](http://www.WTW.com).

**Copyright**

© Weilheim 2015, WTW GmbH  
Reproduction in whole - or even in part - is prohibited without the express written permission of WTW GmbH, Weilheim.  
Printed in Germany.

## Contents

<b>1</b>	<b>Overview</b>	<b>5</b>
1.1	Overview of the instrument	5
1.2	Keypad	6
1.3	Display	8
<b>2</b>	<b>Safety</b>	<b>9</b>
2.1	Safety information	9
2.1.1	Safety information in the operating manual	9
2.1.2	Safety signs on the product	9
2.1.3	Further documents providing safety information	9
2.2	Safe operation	10
2.2.1	Authorized use	10
2.2.2	Requirements for safe operation	10
2.2.3	Unauthorized use	10
2.3	User qualification	10
2.4	Handling of hazardous substances	11
<b>3</b>	<b>Commissioning</b>	<b>12</b>
3.1	General notes on handling	12
3.2	Initial commissioning	12
3.2.1	Inserting the buffer batteries	13
3.2.2	Connecting the power supply	13
3.2.3	Switching on the photometer and setting the language	14
3.2.4	Set the date and time	15
<b>4</b>	<b>Operation</b>	<b>16</b>
4.1	Switching on or off the photometer	16
4.2	General operating principles	18
4.2.1	Navigating with function keys and menus	18
4.2.2	Display of navigation paths in short form	19
4.2.3	Entry of numerals, letters and characters	21
4.3	Zero adjustment	22
4.4	Measuring in <i>Concentration</i> mode	26
4.4.1	Measuring cell tests with barcode	26
4.4.2	Measuring reagent tests with AutoSelector	27
4.5	Measuring the Absorbance / % Transmission	29
4.5.1	General information	29

4.5.2	Measuring the absorbance or transmission . . . .	29
<b>5</b>	<b>Maintenance and cleaning . . . . .</b>	<b>31</b>
5.1	Exchanging the buffer batteries . . . . .	31
5.2	Cleaning . . . . .	32
5.2.1	Cleaning the enclosure . . . . .	32
5.2.2	Cleaning the cell shaft . . . . .	32
5.2.3	Cleaning the detector lens . . . . .	33
<b>6</b>	<b>What to do if ... . . . . .</b>	<b>34</b>
6.1	Actions in the case of a broken cell . . . . .	34
6.2	Error causes and remedies . . . . .	35
<b>7</b>	<b>Technical data . . . . .</b>	<b>38</b>
7.1	Measurement characteristics . . . . .	38
7.2	Measured value documentation and quality assurance . .	41
7.3	General meter data . . . . .	41

# 1 Overview

## 1.1 Overview of the instrument

Front of the instrument

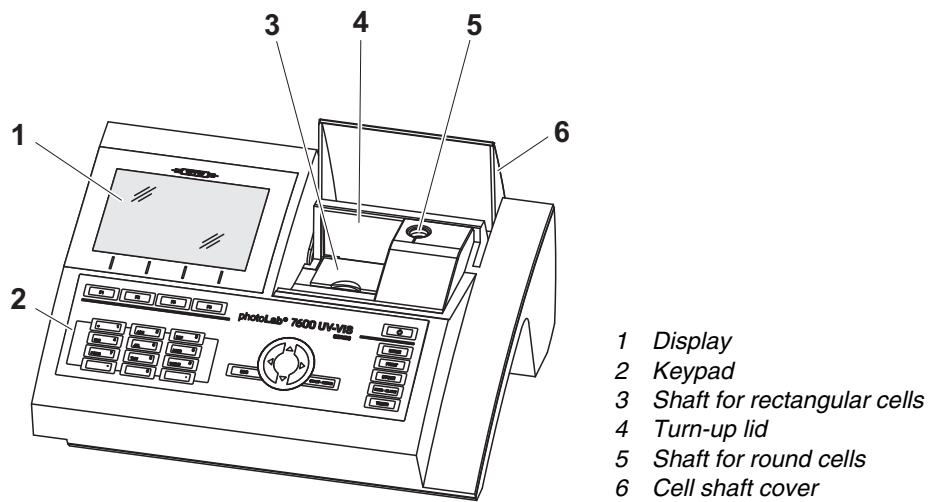

Fig. 1-1 Front of the instrument with operating elements

Socket field on the rear panel

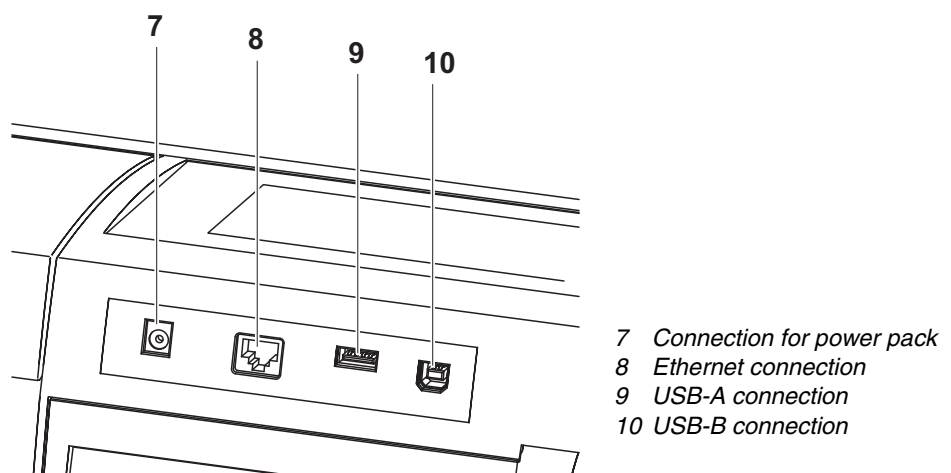

Fig. 1-2 Rear panel with socket field



All connections comply with SELV.

## 1.2 Keypad

### Overview

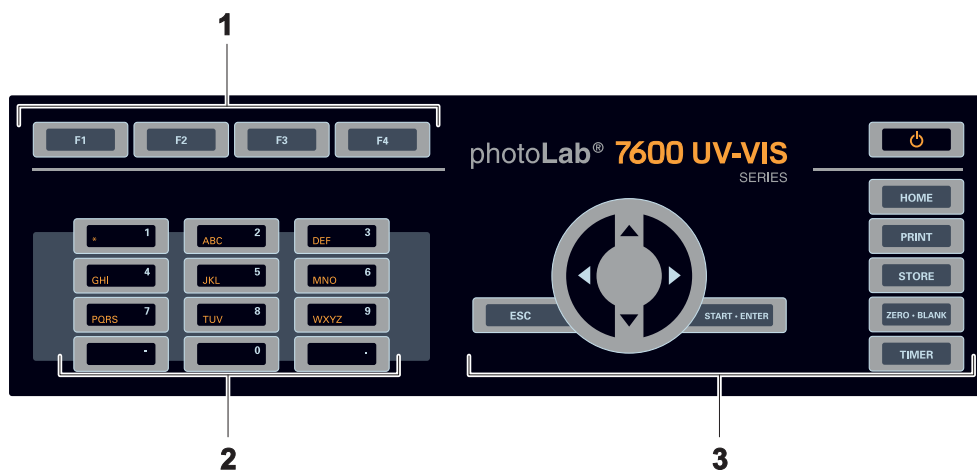



- 1 Function keys F1 to F4 (function menu-dependent)
- 2 Alphanumeric keypad
- 3 Keys with dedicated function

Fig. 1-3 Keypad

### Key functions

The keys on the right side of the keypad have the following functions:

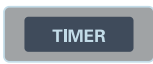
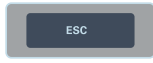
Key	Designation	Functions
	<ON/OFF>	– Switches the photometer on and off
	<HOME>	– Switches to the main menu from any operating situation. Actions that are not completed are canceled.
	<PRINT>	– Outputs the displayed measured value to an interface if the <i>Printer</i> symbol is displayed in the status line.
	<STORE>	– Saves a displayed measured value or spectrum if the <i>Save</i> symbol is displayed in the status line.
	<ZERO-BLANK>	– Starts one of the following measurements, depending on the operating situation: - Zero adjustment - Blank value measurement - Baseline measurement - User calibration

Key	Designation	Functions
	<TIMER>	– Opens the menu, <i>Timer</i> .
	<ESC>	– Cancels the running action. Entries that have not yet been accepted are discarded. – Switches to the next higher menu level.
	<START·ENTER>	– Starts an action (e.g. measurement) – Opens a selected menu – Confirms a selection or entry
 (arrow keys)	<▲> or <▼>	– Moves the selection in menus and lists one position up or down
	<◀>	– When entering characters, deletes the character left of the cursor – Moves the cursor to the left in a spectrum or kinetic diagram
	<▶>	– Moves the cursor to the right in a spectrum or kinetic diagram

**Function keys**

The function keys F1 to F4 have different functions depending on the operating situation. The current functions are displayed in the function key menu at the bottom edge of the display (see section 4.2.1).

### 1.3 Display

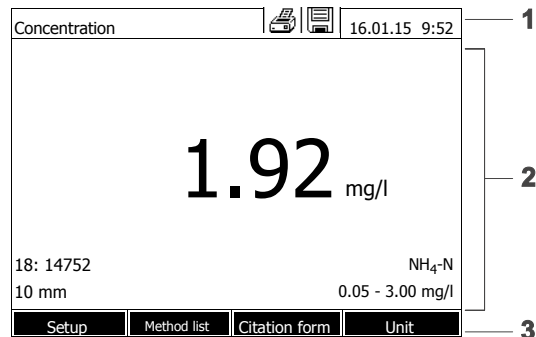

#### Display element



- 1 Status line (current state, date and time)
- 2 Display range for menus and measurement results
- 3 Function keys menu

Fig. 1-4 Display

#### Symbols in the status line

Symbol	Designation	Function
	Save	The <STORE> key is active. You can store the displayed data with <STORE>.
	Printer	The <PRINT> key is active. You can output to an interface the displayed data with <PRINT>.



## 2 Safety

### 2.1 Safety information

#### 2.1.1 Safety information in the operating manual

This operating manual provides important information on the safe operation of the product. Read this operating manual thoroughly and make yourself familiar with the product before putting it into operation or working with it. The operating manual must be kept in the vicinity of the product so you can always find the information you need.

Important safety instructions are highlighted in this operating manual. They are indicated by the warning symbol (triangle) in the left column. The signal word (e.g. "CAUTION") indicates the level of danger:



#### **WARNING**

indicates a possibly dangerous situation that can lead to serious (irreversible) injury or death if the safety instruction is not followed.



#### **CAUTION**

indicates a possibly dangerous situation that can lead to slight (reversible) injury if the safety instruction is not followed.

#### **NOTE**

*indicates a situation where goods might be damaged if the actions mentioned are not taken.*

#### 2.1.2 Safety signs on the product

Note all labels, information signs and safety symbols on the product. A warning symbol (triangle) without text refers to safety information in this operating manual.

#### 2.1.3 Further documents providing safety information

The following documents provide additional information, which you should observe for your safety when working with the measuring system:

- Operating manuals of other components of the photoLab® 7600 UV-VIS (accessories)
- Safety datasheets for chemicals.

## 2.2 Safe operation

### 2.2.1 Authorized use

The authorized use of the photometer consists exclusively of the carrying out of photometric measurements according to this operating manual. Follow the technical specifications of the cells in chapter 7 TECHNICAL DATA. Any other use is considered **unauthorized**.

### 2.2.2 Requirements for safe operation

Note the following points for safe operation:

- The product may only be operated according to the authorized use specified above.
- The product may only be supplied with power by the energy sources mentioned in this operating manual.
- The product may only be operated under the environmental conditions mentioned in this operating manual.
- The product may not be opened.

### 2.2.3 Unauthorized use

The product must not be put into operation if:

- it is visibly damaged (e.g. after being transported)
- it was stored under adverse conditions for a lengthy period of time (storing conditions, see chapter 7 TECHNICAL DATA).

## 2.3 User qualification

Carrying out photometric determinations with the aid of test sets frequently requires the handling of hazardous substances.

We assume that the operating personnel know how to handle hazardous substances due to their professional training and experience. The operating personnel must particularly be able to understand and correctly implement the safety labels and safety instructions on the packages and inserts of the test sets.

## 2.4 Handling of hazardous substances

When developing test sets, WTW carefully sees that the tests can be carried out as safely as possible. Some hazards by dangerous substances, however, cannot always be avoided.

If self-produced tests or solutions are used, the responsibility concerning any risks caused by those tests or solutions lies with the user (personal responsibility).



### **WARNING**

**Improper handling of certain reagents can cause damage to your health.**

**In any case follow the safety labels on the packing and the safety instructions of the package insert. Protective measures specified there have to be followed exactly.**

### **Safety datasheets**

The safety datasheets of the chemicals comprise all instructions on safe handling, occurring hazards, preventive actions and actions to take in hazardous situations. Follow these instructions in order to work safely.

## 3 Commissioning

### 3.1 General notes on handling

The photoLab® 7600 UV-VIS photometer is an optical precision meter. Therefore, it should always be handled with care, especially in mobile use. Always protect the meter from conditions that could damage the mechanical, optical and electronic components. Heed the following points especially:

- The temperature and humidity during operation and storage must be within the limits specified in chapter 7 TECHNICAL DATA.
- The following influences always have to be avoided with the meter:
  - Extreme dust, moisture and wetness
  - Exposure to intensive light and heat
  - Fumes that are corrosive or contain high concentrations of solvents.
- For measuring, the meter must be placed on a flat surface.
- Spilled liquid or other material should be removed immediately (see section 5.2 CLEANING).
- If a cell has broken in the cell shaft, the cell shaft should be cleaned immediately (see section 6.1 ACTIONS IN THE CASE OF A BROKEN CELL).
- The cell shaft should always be closed when the photometer is not used.
- During transport of the photometer, the cell shaft has to be empty.
- For mobile use we recommend the transport case.

### 3.2 Initial commissioning

Perform the following activities:

- Insert the buffer batteries (see section 3.2.1)
- Connect the power supply (see section 3.2.2)
- Switch on the photometer (see section 3.2.3)
- Set the language (see section 3.2.3)
- Set the date and time (see section 3.2.4)
- Carry out zero adjustment (see section 4.3)

#### Packing

This photometer is sent out in a protective transport packing.



#### CAUTION

**Keep the original packing including the inner packing to protect the instrument against hard shocks if it has to be transported. The original packing is also required for the proper return of the instru-**

ment if it has to be repaired.

**Note that damage caused by improper transport voids all warranty claims.**

### 3.2.1 Inserting the buffer batteries

The buffer batteries supply the integrated clock while the photometer is switched off. Four alkaline manganese batteries (type AA or Mignon) separately included in the scope of delivery are used as the buffer batteries.

Insert the batteries as follows:

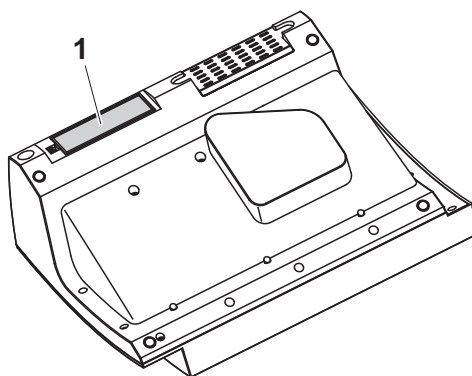

- 1 Turn the photometer upside down and place it on a soft surface.
- 2 Open the lid of the battery compartment (1).
- 3 Insert the four batteries in the battery compartment. Make sure that the poles of the batteries are in the correct position. The  $\pm$  signs on the batteries must correspond to the  $\pm$  signs in the battery compartment.
- 4 Close the lid of the battery compartment.

### 3.2.2 Connecting the power supply

The power is supplied via the enclosed plug-in power pack. The power pack supplies the photometer with low voltage (12 VDC).



#### **CAUTION**

**The line voltage of the usage location must fulfill the specifications stated on the power pack (the specifications are also given in chapter 7 TECHNICAL DATA). Always use the supplied 12 V original power pack only.**

**Before plugging in the power cable check whether it is undamaged. If the power cable is damaged, the instrument must not be operated.**

### Connecting the plug-in power pack

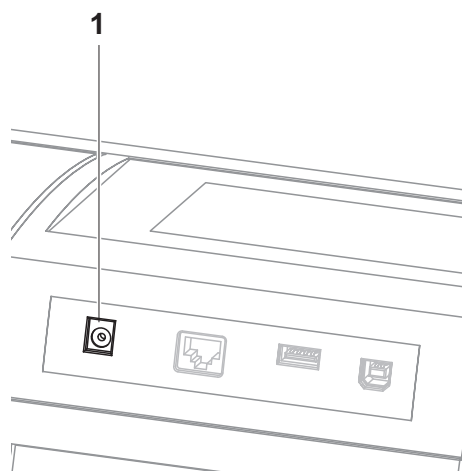

- 1 Connect the miniplug of the power pack to the socket (1) of the photometer.
- 2 Connect the plug-in power supply unit to an easily accessible mains socket.  
The display illumination switches itself on and then off again.

### 3.2.3 Switching on the photometer and setting the language

During the initial commissioning the photometer automatically guides you to the setting of the meter language after switching on (<ON/OFF>).

General setup	16.01.15 9:52
German	
✓ English	
Français	
Español	
Italiano	
Bulgarian/Български	
Česko	
Simplified Chinese/ 中	
Traditional Chinese/ 繁	
Greek/Ελληνικά	

- 1 Select a language with <▲><▼>.
- 2 Confirm the selected language with <START·ENTER>.  
The language has been set.  
The currently selected language is marked by a tick.  
The display switches to the setting of *Date and Time*.

After the initial commissioning, you can change the language in the *General setup / Language* menu at any time.

### 3.2.4 Set the date and time

During the initial commissioning, the instrument automatically guides you to the setting of the time and date after the setting of the language.

Date/Time	16.01.15 9:52
Date	16.01.2015
Time	9:52:09
OK	

The *Date/Time* menu is open.

Using <▲><▼>, select a menu item and confirm or open it with <START·ENTER> .

- 1 Select and confirm *Date*.

The input field for the current date pops up.

Date/Time	16.01.15 9:52
Date	16.01.2015
Time	9:52:09
OK	

Date	16 .01.2015
------	-------------

- 2 Enter the current date with <0...9> and confirm.

The input field closes.  
The date is accepted.

- 3 Select and confirm *Time*.

The input field for the current time pops up.

Date/Time	16.01.15 9:52
Date	16.01.2015
Time	9:52:09
OK	

Time	09 : 52 : 09
------	--------------

- 4 Enter the current time with <0...9> and confirm.

The input field closes.  
The time is accepted.

After the initial commissioning, you can change the date and time in the *General setup / Date/Time* menu at any time.

## 4 Operation

### 4.1 Switching on or off the photometer

#### Switching on

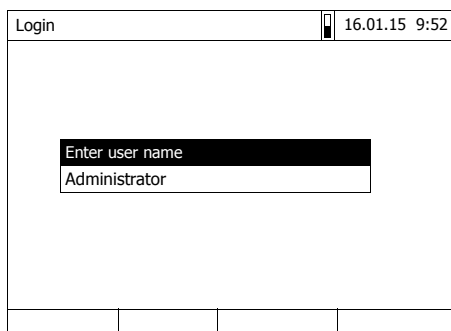
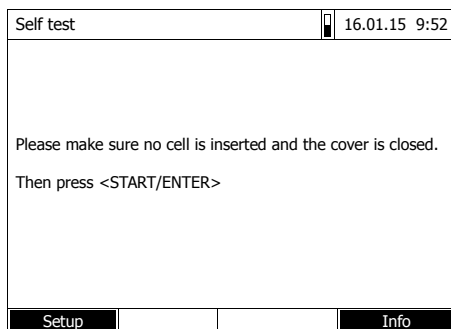

- 1 Switch the photometer on with **<ON/OFF>**.

The display shows

- the *Self test* dialog (if the user management is not active).

or

- the *Login* dialog (if the user management is active).

With activated user management:

- 2 Login

Enter user name and password or log in as a guest.

Then the *Self test* dialog is displayed.

#### Starting the *Self test*

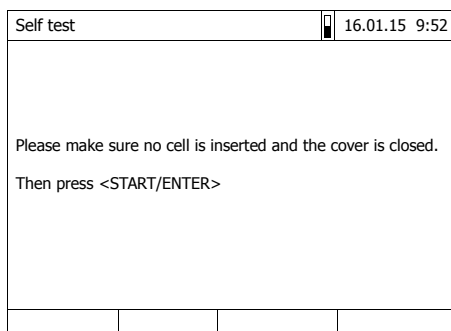

- 3 Remove all cells and close the cell shaft cover.

- 4 Start the self-test with **<START·ENTER>**.

The photometer carries out the self-test.

#### Self test

During the self-test, all cells must be removed and the cell shaft cover closed. The self-test runs in the background and may take some minutes.



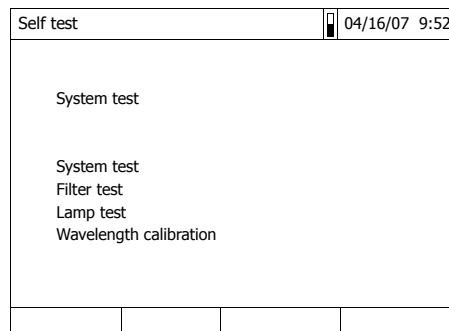

The self-test includes:

- the test of the memory, processor, internal interfaces, filter and lamp
- a calibration for each wavelength

After the self-test is completed, the main menu is displayed.



The result of the self-test can be viewed and printed with the *[Info]* function key.

### Switching off

To switch the photometer off, keep the **<ON/OFF>** key depressed until the photometer is switched off.

## 4.2 General operating principles

### 4.2.1 Navigating with function keys and menus

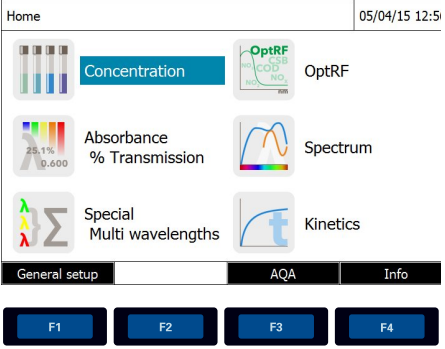

Home 05/04/15 12:5

Concentration OptRF

Absorbance % Transmission Spectrum

Special Multi wavelengths Kinetics

General setup AQA Info

F1 F2 F3 F4

Press the <▲><▼> <◀><▶> key.

The menu selection moves in the corresponding direction.

→

<▲><▼>

<◀><▶>

Press the function key <F1> ([Setup]). The *General setup* submenu pops up.

<F1>

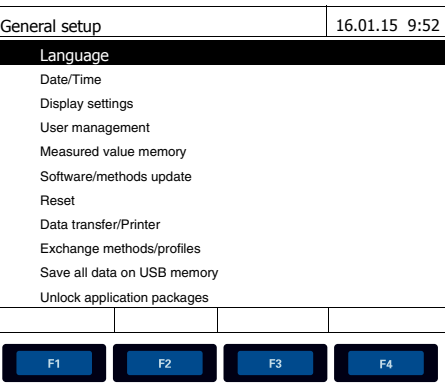

General setup 16.01.15 9:52

Language

Date/Time

Display settings

User management

Measured value memory

Software/methods update

Reset

Data transfer/Printer

Exchange methods/profiles

Save all data on USB memory

Unlock application packages

F1 F2 F3 F4

Press the <START·ENTER> key. This has confirmed the current selection. A new menu pops up.

<START·ENTER>

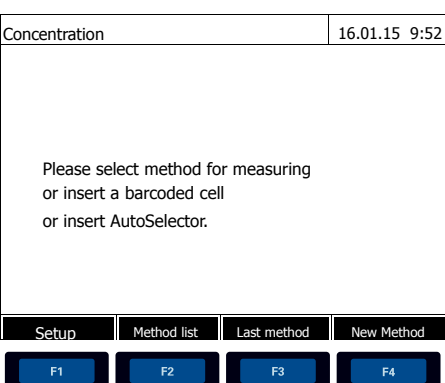

Concentration 16.01.15 9:52

Please select method for measuring or insert a barcoded cell or insert AutoSelector.

Setup Method list Last method New Method

F1 F2 F3 F4

To navigate further, use <▲><▼> <◀><▶> and <START·ENTER>

Further navigation with function keys (here: F1 and F2)

The current menu selection is displayed in reverse video. The assignment of the function key menu is adapted to the current operating situation. The functions of the function key menu are started with the function keys (F1 ... F4).

**Use of the function keys**

The function keys F1 to F4 are below the display. Their functions change depending on the operating situation and mode. The current functions are displayed in the function key menu at the bottom edge of the display.

Apart from navigation, the function keys are also used for other operations:

- Opening a selection list or input field
- Executing a command (directly or with intermediate query)
- Switch over between two display options, such as absorbance ↔ transmission

**Navigation with arrow keys (<▲><▼>) and <START·ENTER>**

These operating elements are used to select an item from a menu or list. The current selection is displayed in reverse video. Pressing of <START·ENTER> confirms the selection.

Apart from navigation, the <START·ENTER> key is also used for other operations:

- Opening a selection list or input field
- Confirming a selection
- Confirming entries of text and numerals
- Executing a command (directly or with intermediate query)
- Activating an item in a selection list (✓ = active)

#### 4.2.2 Display of navigation paths in short form

In this operating manual, the introductory navigation steps leading to individual menus or dialogs are clearly shown in a gray box. The box indicates a section of the menu tree.

Starting point of the description is always the main menu, which can be reached with the <HOME> key from any operating situation. From there navigation takes place downward.

**Operating example:  
Navigation to the  
setting menu for the  
language**

The following example shows the elements of the menu tree with the relevant operating steps:

```

<HOME>
[General setup]
|
|_ Language
  
```

Bold letters and angle brackets indicate a key on the photometer (except function keys).

→ Press the "Home" key.  
The main menu is called up.

Square brackets in this operating manual indicate a function key F1 to F4. The text between the brackets corresponds to the assignment according to the function key menu on the bottom edge of the display.

→ Press the function key with the assignment "Settings"

Text without brackets stands for a menu item indicated on the display (list item).

→ Select the menu item with the arrow keys <▲><▼>. The current selection is displayed in reverse video.

→ Then press  
**<START·ENTER>**.

Further navigation options:

- The <ESC> key moves you one level up in the menu tree.
- The <HOME> key directly calls up the main menu.



If you are "lost" in a menu, press <HOME> and restart navigating from the main menu.

### 4.2.3 Entry of numerals, letters and characters

Numerals, letters, punctuation marks and special characters are entered with the alphanumeric keypad of the meter or using an external keyboard.



The numerals and characters (except for the small letters) assigned to the keys of the alphanumeric keypad are printed on the keys. Example: With the **<7/PQRS>** key you can enter the following characters: 7, P, Q, R, S, p, q, r, s.

Select the required character by pressing the key several times (similar to a mobile phone). When pressing a key that is assigned to several characters once, the respective numeral appears first. To enter a numeral, one keypressing is always sufficient.

When pressing the key for the first time a line pops up that displays all characters possible with this key. The currently selected character is highlighted.

A character is taken over in the input field if

- the character is highlighted for more than one second,
- the character is confirmed with **<START·ENTER>**,
- another alphanumeric key is pressed.

#### Special characters

Special characters are entered with the **<1/\*>** key.

#### Operating example: Entering the ID

The *Enter ID* input field appears if you press the **<STORE>** key while the storing symbol is visible. In the following example a measurement dataset with the ID "Test" is stored.

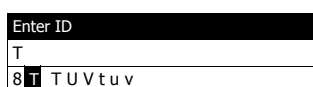
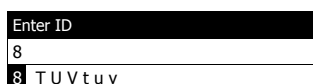

- 1 Press **<8/TUV>** several times until "T" appears in the input line.

Below the input field, a selection line pops up with all characters that are available for this key, e.g. *8 T U V t u v*.

The currently selected character is highlighted.

After approx. one second the character is taken over and the selection line closed.

- 2 Complete the ID with **<A...9>** and confirm.

#### Correcting incorrect entries

Using **<◀>**, erase all characters until you have reached the incorrect digit and repeat the entry from there.

### 4.3 Zero adjustment

A valid zero adjustment is required for the calculation of measured values in the modes, *Concentration*, *Absorbance / % Transmission*, *Multi wavelengths* and *Kinetics*. With a zero adjustment, the absorbance of a cell filled with distilled water ("zero cell") is measured and stored.

#### Factory zero adjustment for concentration measurements

For all measurements with WTW test sets (*Concentration* mode), a factory zero adjustment is available in the delivery condition. We recommend replacing it with a zero adjustment of your own. If a zero adjustment exists already for a method, the date and time of the last zero adjustment are displayed in the top right area of the display.

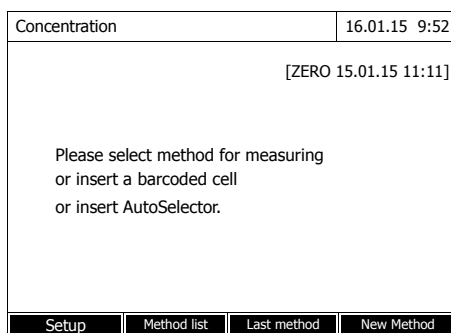

#### Zero adjustment for absorbance measurements

In the *Absorbance* mode, the zero adjustment has to be carried out separately for each cell type and each used wavelength. If a zero adjustment exists already for the inserted cell type at the selected wavelength, the date and time of the last zero adjustment are displayed in the top right area of the display.

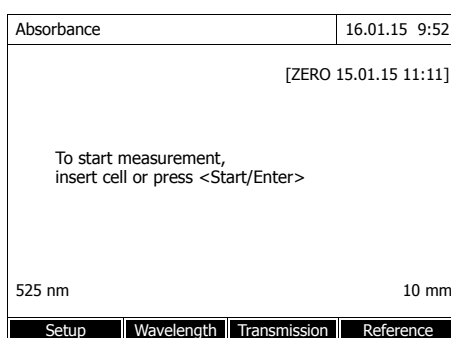

If no zero adjustment is available, the photometer will prompt you to carry out a zero adjustment.



The cells must be absolutely clean and free of scratches. Always use a cell of the same type for zero adjustment and measurement of the sample.

### Notes on zero adjustment

Zero adjustment with round cells:

- Only use clean, scratch-free round cells with distilled water. The minimum filling level is 20 mm. A ready zero cell is included in the scope of delivery of the photometer and PhotoCheck.
- A ready zero cell can, in principle, be used any number of times. We recommend, however, to regularly check the zero cell for visible contamination and scratches and refill or exchange it if necessary (at least every 24 months).

Zero adjustment with rectangular cells:

- For rectangular cells, the zero adjustment must be carried out with the same cell type (manufacturer and cell material [e.g. optical glass, quartz glass, plastic]) that is used for measurement. This is important because cells of different manufacturers have a different absorption behavior. When changing the cell type repeat the zero adjustment with the new type.
- Prior to zero adjustment, clean the rectangular cell and fill it with distilled water. The minimum filling level is 20 mm.
- Rectangular cells always have to be inserted in the cell shaft with the same orientation for measurement and zero adjustment (e.g. cell printing on the left side).



General requirements of the cells are given in chapter 7 TECHNICAL DATA. Note that the spectral transparency of the cell must be suitable for the intended application (example, quartz cell for UV range).

### Carrying out a zero adjustment

The zero adjustment takes place similarly in the *Concentration*, *Absorbance / % Transmission*, *Multi wavelengths* and *Kinetics* modes.

- 1 In the respective mode, press the **<ZERO-BLANK>** key.
- 2 In *Concentration* mode only:  
Select and confirm *Zero adjustment*.

Concentration	16.01.15 9:52
<div style="border: 1px solid black; padding: 5px; margin: 10px auto; width: fit-content;">           Adjust            Zero adjustment            Reagent blank value            Calibrate the method         </div>	
3: A6/25 16 mm	NH <sub>4</sub> -N 0.20 - 8.00 mg/l
Setup	Method list
Citation form	Unit

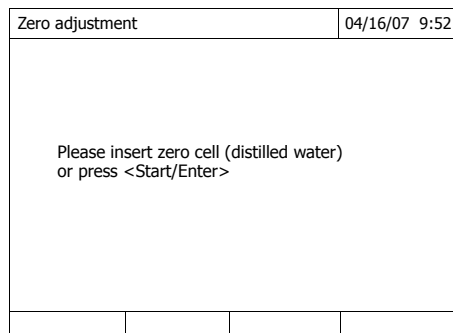

The zero adjustment window pops up.

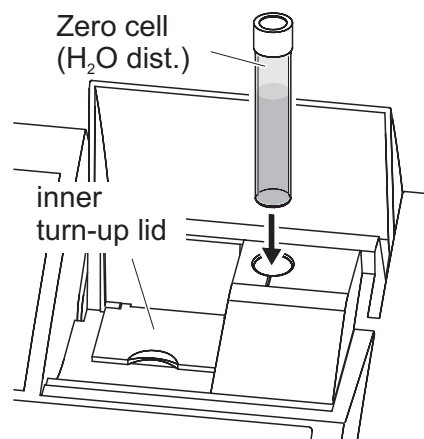

- 3 Close the inner turn-up lid.
- 4 Depending on the cell type, insert the zero cell as follows:

Round cell:

Insert the round cell in the round cell shaft so it touches the bottom.

If the inner turn-up lid is opened too wide, a message prompts you to close the inner turn-up lid.

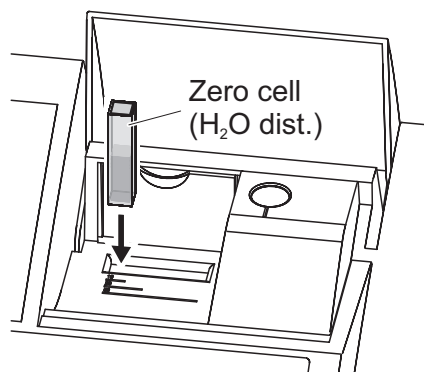

Rectangular cell:

Open the inner turn-up lid.

Insert the rectangular cell vertically so it touches the bottom and left edge of the cell shaft. The opaque sides of the rectangular cell must point to the front and back.

The photometer has an external light recognition. If there is too much external light, a message prompts you to close the cell shaft cover.

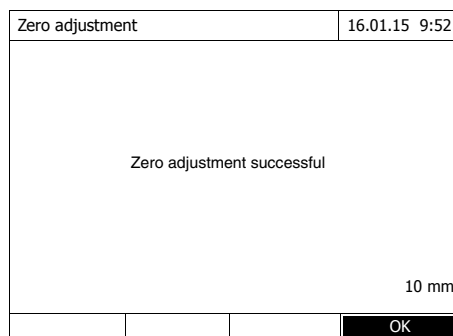

The photometer automatically starts the zero adjustment and subsequently stores the value.

- 5 After a successful zero adjustment switch to measurement with [OK].



**Validity of the zero adjustment**

The data of the zero adjustment is stored in the photometer separately for each cell type. As long as the data is valid, it is automatically used again after a temporary change to a different cell type. The validity depends on the respective mode:

Mode	Validity of the zero adjustment
<i>Concentration</i> (permanently programmed methods)	● Till the next zero adjustment
<i>Absorbance / % Transmission</i>	● Till the next zero adjustment with the same wavelength *
<i>Concentration</i> (user-defined methods) and <i>Multi wavelengths</i>	● Till the next zero adjustment for the same method *
<i>Kinetics</i>	<ul style="list-style-type: none"> <li>● Till another kinetic profile is loaded</li> <li>● Till the <i>Kinetics</i> mode is exited or the photometer is switched off</li> </ul>

\* After the wavelength or method respectively was temporarily exited the photometer displays that a zero adjustment is available and the time it was carried out. You can then decide whether to use this zero adjustment or carry out a new zero adjustment.

**When to repeat the zero adjustment?**

We recommend to repeat the zero adjustment in the following cases:

- If the photometer was subject to mechanical stress such as strong shock or transport
- If the ambient temperature changed by more than 5 °C since the last zero adjustment
- At least once per week
- If a new cell type (different manufacturer, different glass type is used)
- Basically each time you want to measure with the highest possible accuracy.

## 4.4 Measuring in *Concentration* mode

### 4.4.1 Measuring cell tests with barcode

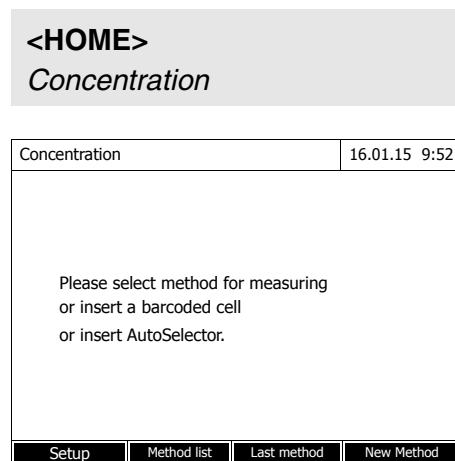

Inserting a cell with barcode starts a measurement.

If a cell without barcode is used: Select a method.

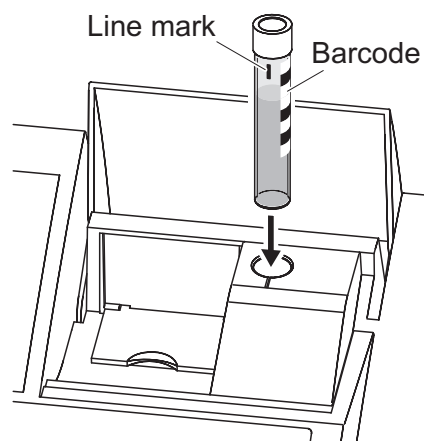

- 1 Open the cell shaft cover.
- 2 Close the inner turn-up lid.  
If the inner turn-up lid is opened too wide, a message prompts you to close the inner turn-up lid.
- 3 Insert the barcoded round cell in the round cell shaft so it touches the bottom. When doing so, align the line mark with the notch at the front of the round cell shaft.

The photometer selects the method with the aid of the barcode and starts measuring automatically.

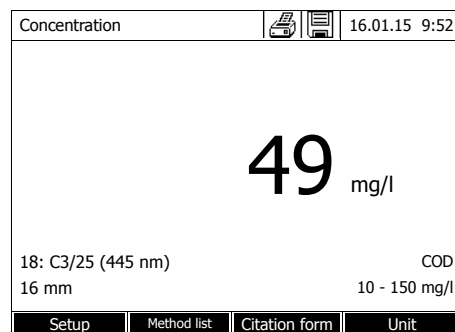

- 4 Further options:
  - Select a different citation form with *[Citation form]*, (e.g.  $\text{NH}_4 \leftrightarrow \text{NH}_4\text{-N}$ ).
  - Select a different measuring unit with *[Unit]*, (e.g.  $\text{mg/l} \leftrightarrow \text{mmol/l}$ ).
  - Make further settings such as dilution or blank value measurements with *[Setup]*.

#### 4.4.2 Measuring reagent tests with AutoSelector

<HOME>  
Concentration

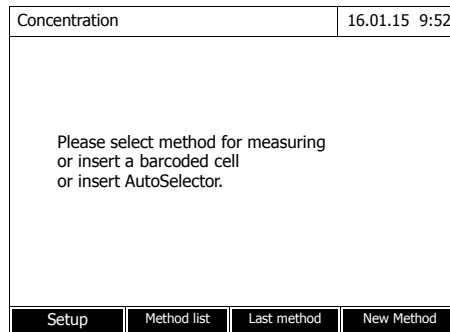

1 Open the cell shaft cover.

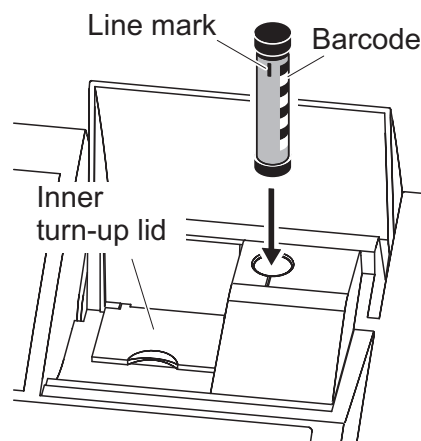

2 Insert the AutoSelector in the round cell shaft so it touches the bottom. When doing so, align the line mark with the notch at the front of the round cell shaft.

- The photometer selects the correct method with the aid of the barcode.

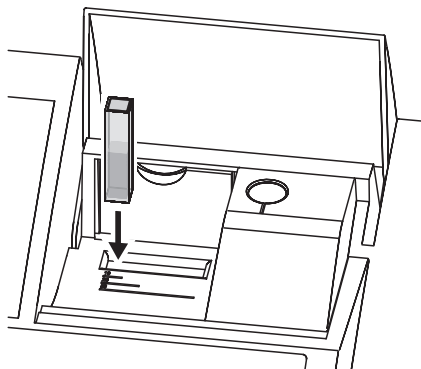

- 3 Open the inner turn-up lid.
- 4 Insert the rectangular cell vertically so it touches the bottom and left edge of the cell shaft. The opaque sides of the rectangular cell must point to the front and back.

The correct measuring range is automatically selected when the rectangular cell (1, 2, 5 cm) is inserted.

The photometer has an external light recognition. If there is too much external light, a message prompts you to close the cell shaft cover.

The photometer starts measuring automatically.

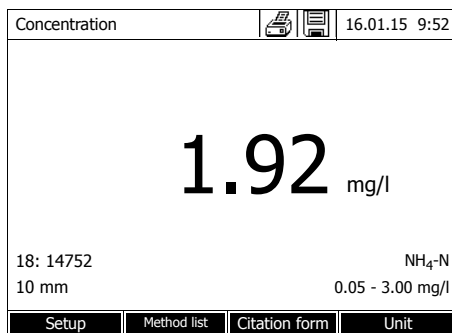

- 5 Further options:
  - Select a different citation form with *[Citation form]*, (e.g. NH<sub>4</sub> <-> NH<sub>4</sub>-N).
  - Select a different measuring unit with *[Unit]*, (e.g. mg/l <-> mmol/l).
  - Make further settings such as dilution or blank value measurements with *[Setup]*.

## 4.5 Measuring the Absorbance / % Transmission

### 4.5.1 General information

The absorbance or transmission respectively is measured without the use of any methods or profiles. All settings are configured during measurement.

#### Measuring against the Reference absorbance

The absorbance or transmission can alternatively be measured against the absorbance of the zero adjustment or against a *Reference absorbance* determined by yourself.

### 4.5.2 Measuring the absorbance or transmission

<HOME>

Absorbance / % Transmission

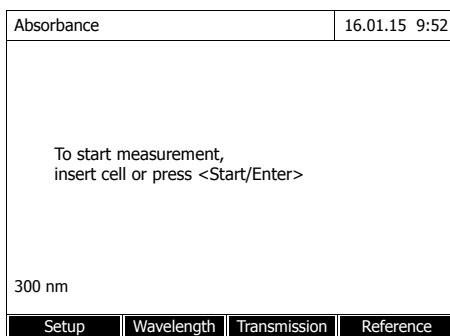

The settings of the last measurement are active.

- 1 Using *[Wavelength]*, change the wavelength as necessary.
- 2 Using *[Absorbance]* <-> *[Transmission]*, you can switch over between absorbance and transmission measurement.
- 3 If necessary, use a reference measurement with *[Reference]* or measure a new one.
- 4 Depending on the type, insert the cell as follows:

#### Round cell:

Insert the round cell in the round cell shaft so it touches the bottom.

If the inner turn-up lid is opened too wide, a message prompts you to close the inner turn-up lid.

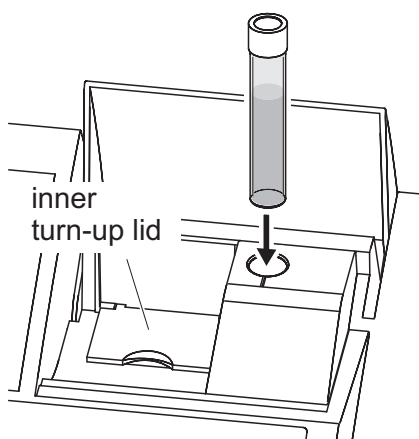

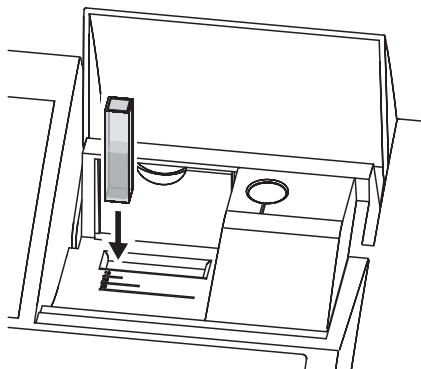

**Rectangular cell:**

Open the inner turn-up lid.

Insert the rectangular cell vertically so it touches the bottom and left edge of the cell shaft. The opaque sides of the rectangular cell must point to the front and back.

The photometer has an external light recognition. If there is too much external light, a message prompts you to close the cell shaft cover.

The photometer starts measuring automatically.

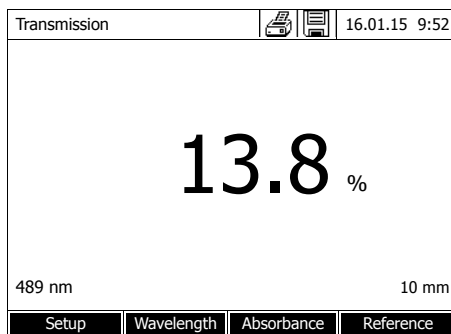
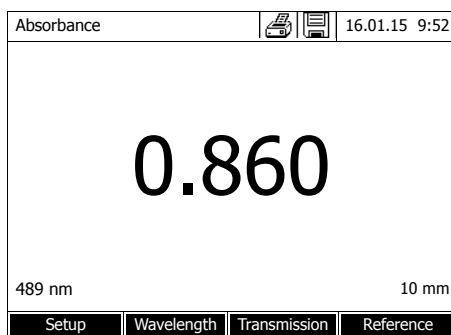

- 5 Using [Absorbance] <-> [Transmission], switch over the display from Absorbance to Transmission or vice versa as necessary.

## 5 Maintenance and cleaning

### 5.1 Exchanging the buffer batteries



#### CAUTION

There is a risk of explosion if unsuitable batteries are used. Only use leakproof alkaline manganese batteries.



If you leave the photometer switched on during the exchange or insert the new batteries within a minute after taking out the old ones, the date and time are retained in the photometer.

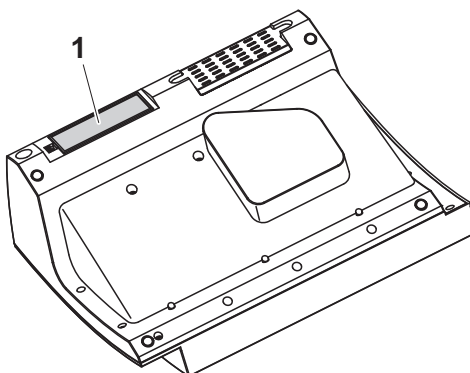

- 1 Turn the photometer upside down and place it on a soft surface.
- 2 Open the lid of the battery compartment (1).
- 3 Remove the old batteries from the battery compartment.
- 4 Insert the four new batteries in the battery compartment. Make sure that the poles of the batteries are in the correct position. The  $\pm$  signs on the batteries must correspond to the  $\pm$  signs in the battery compartment.
- 5 Close the lid of the battery compartment.

#### Battery service life

The power consumption of the clock is very low. The lifetime of high quality batteries is at least 5 years.

#### Disposal of batteries

Dispose of the batteries at a suitable facility according to local legal requirements. It is illegal to dispose of the batteries with household refuse.

Within the European Union, the batteries are removed at a specialized treatment center at the instrument's end of life. The instruments are taken to one of those specialized treatment centers via the recycling system set up for this purpose.

## 5.2 Cleaning

Especially after a cell has broken or after a reagents accident, the photometer should immediately be cleaned (see also section 6.1 ACTIONS IN THE CASE OF A BROKEN CELL).

### 5.2.1 Cleaning the enclosure

#### NOTE

*The housing components are made out of synthetic materials (ABS, PMMA and PC). Thus, avoid contact with acetone, ethyl alcohol and similar detergents that contain solvents. Remove any splashes immediately.*

Clean the photometer enclosure as follows:

- If the housing surface is dirty, wipe it with a soft cloth and mild soapy water.
- Remove any chemicals splashes as soon as possible.
- For disinfection, you can use isopropanol for cleaning for a short time.

### 5.2.2 Cleaning the cell shaft

#### NOTE

*The housing components are made out of synthetic materials (ABS, PMMA and PC). Thus, avoid contact with acetone, ethyl alcohol and similar detergents that contain solvents. Remove any splashes immediately.*



If a cell has broken, the cell shaft has to be cleaned immediately. To do so, proceed as described in section 6.1.

Normally, it is not required to clean the cell shaft routinely. Remove dust and slight contamination with a moist, lint free cloth. Use isopropanol briefly to remove persistent coatings (e.g. reagent remains). Especially clean the bottom parts of the lateral surfaces of the rectangular cell shaft where the light barriers for the automatic cell recognition are located.



### 5.2.3 Cleaning the detector lens

Normally, it is not required to clean the detector lens routinely. Cleaning the detector lens can be necessary in the following cases:

- If the lens is visibly smudged, e.g. after a cell has broken or after a reagent accident (see also section 6.1 ACTIONS IN THE CASE OF A BROKEN CELL).
- If, due to environmental influences or reagent contamination, the photometer displays the message, *Wavelength calibration* during the self-test after being switched on (see section 6.2)



If the lens is often smudged (error, *Wavelength calibration* during the self-test), check whether the correct operating conditions are observed. Follow the details in section 3.2 for this purpose.

Proceed as follows to clean the detector lens:

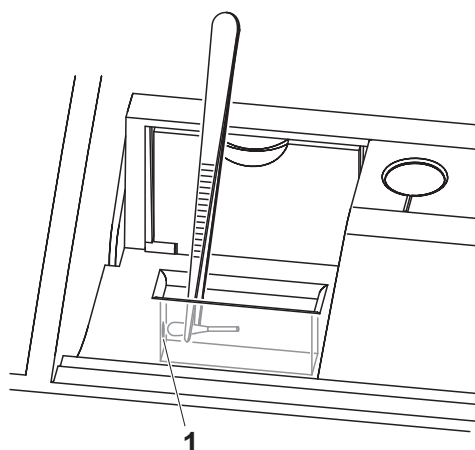

The detector lens is on the front left side of the rectangular cell shaft (pos. 1).

- 1 Switch off the photometer.
- 2 Cut off one end of a customary cotton swab (approx. 2 cm).
- 3 Grasp the cut-off end with the tip of a pair of tweezers or small pliers. Clean the lens with the dry head of the cotton swab. To do so, move the head from the center of the lens outward in circles. If there are persistent coatings, moisten the cotton swab with a little deionized water or isopropanol.



After recommissioning, carry out the photometer monitoring for all measurements.

## 6 What to do if ...

### 6.1 Actions in the case of a broken cell



#### WARNING

Cells can contain dangerous substances. If the contents are released, follow the safety instructions of the package insert. If necessary, take corresponding protective measures (protective goggles, protective gloves etc.).



#### CAUTION

Do not turn the photometer upside down or laterally to remove the liquid!

When doing so, the liquid could come into contact with electronic components and damage the photometer.

The photometer has a drain device through which the contents of a broken cell can drain off without causing any damage.

#### Proceeding after a cell has broken

- 1 Switch off the photometer and disconnect it from the power supply.
- 2 Let the liquid drain off into a suitable container and dispose of it properly according to the instructions of the reagent package.
- 3 Carefully remove all broken glass, e.g. with tweezers.
- 4 Carefully clean the cell shaft using a moist, lint-free cloth. If there are persistent coatings, use isopropanol for a short time. Especially clean the bottom parts of the lateral surfaces of the rectangular cell shaft, where the light barriers for the automatic cell recognition are located.
- 5 Let the cell shaft dry.



After recommissioning, carry out the photometer monitoring for all measurements.

If, after recommissioning, an error occurs during the wavelength calibration,

the detector lens is probably smudged. In such a case, clean the lens as follows:

### Cleaning the detector lens

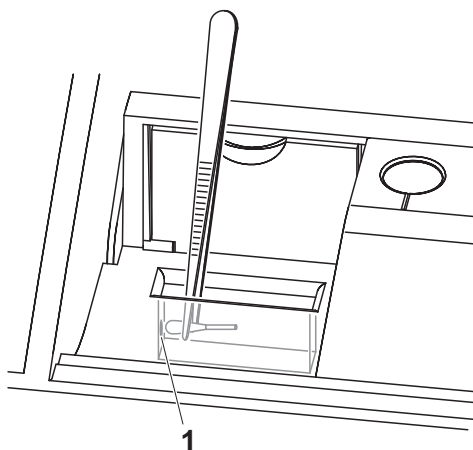

The detector lens is on the front left side of the rectangular cell shaft (pos. 1).

- 1 Switch off the photometer.
- 2 Cut off one end of a customary cotton swab (approx. 2 cm).
- 3 Grasp the cut-off end with the tip of a pair of tweezers or small pliers. Clean the lens with the dry head of the cotton swab. To do so, move the head from the center of the lens outward in circles. If there are persistent coatings, moisten the cotton swab with a little deionized water or isopropanol.

## 6.2 Error causes and remedies

### Instrument does not react to keystroke

Cause	Remedy
– Operating condition undefined or EMC load unallowed	– Processor reset: Press the <ON/OFF> and <ESC> key simultaneously.

### Acoustic signal on keystroke

Cause	Remedy
– The key does not have any function in the current operating state	– Press a different key

### Measuring range undercut or exceeded

Cause	Remedy
– Method not suitable	– Select method with suitable measuring range – Dilute the sample



In *Concentration* mode you can display the current absorbance value as an additional information (*[Setup]/Display absorbance*).

<b>Self-test does not start. The instrument displays Please remove cell</b>	<b>Cause</b>	<b>Remedy</b>
	– A cell is inserted in one of the cell shafts	– Remove the cell – Then press the <b>&lt;START·ENTER&gt;</b> key
	– A foreign object is inserted in one of the cell shafts	– Remove foreign object – Then press the <b>&lt;START·ENTER&gt;</b> key
	– Occasionally, the instrument carries out an automatic readjustment for the rectangular cell recognition. The informative message <i>Please remove cell</i> is displayed even when no cell is inserted.	– Press the <b>&lt;START·ENTER&gt;</b> key.
	– The cell shaft is contaminated	– Clean the cell shaft (see section 5.2.2 and section 6.1) – Restart the instrument – If necessary, confirm the <i>Please remove cell</i> message with <b>&lt;START·ENTER&gt;</b> .
– Instrument defective	– Please contact the service department.	
<b>Obviously incorrect measured values</b>	<b>Cause</b>	<b>Remedy</b>
	– Cell contaminated	– Clean the cell
	– Dilution set incorrectly	– Set the dilution
	– Selected method not suitable	– Select different method
	– Zero measurement incorrect	– Perform zero measurement
– Blank value incorrect	– Remeasure the blank value	
<b>Fluctuating measured values</b>	<b>Cause</b>	<b>Remedy</b>
– Cell shaft cover open	– Close the cell shaft cover	

<b>Self test failed.</b>	<b>Cause</b>	<b>Remedy</b>
	– <i>System test:</i> Instrument defective	– Please contact the service department.
	– <i>Filter test:</i> Instrument defective	– Please contact the service department.
	– <i>Wavelength calibration:</i> – Foreign particle in the cell shaft – Lens smudged  – Instrument defective	– Remove foreign object – Clean the lens (see section 5.2.3 or section 6.1). If this happens repeatedly, check the operating conditions (see section 3.1) – Please contact the service department.
<b>Connected printer does not print</b>	<b>Cause</b>	<b>Remedy</b>
	– Printer not suitable	– Connect a printer that can interpret the printer control language PCL-3
<b>Data transmission to USB memory device does not work</b>	<b>Cause</b>	<b>Remedy</b>
	– Connected USB memory device was not recognized – The USB memory device has been formatted to a file system which is not supported, e. g. NTFS	– Use other USB memory device – Format the USB memory device to the FAT 32 file system

## 7 Technical data

### 7.1 Measurement characteristics

**Measuring principle** Spectrophotometer with reference beam technology

<b>Light source</b>	Lamp type	Xenon flashlamp
	Average lifetime	$5 \times 10^8$ flashes, corresponding to at least 13000 h in permanent operation

<b>Monochromator</b>	Type	Grating monochromator with step motor
	Wavelength range	190 - 1100 nm
	Max. scan speed	approx. 1000 nm/min
	Wavelengths calibration	Automatic
	Accuracy	$\pm 1$ nm
	Reproducibility	$\pm 0.5$ nm (checkable, e.g. with holmium oxide filter)
	Resolution	1 nm
	Spectral band width	4 nm

<b>Photometric measurement</b>	Light sensor	Photo diode
	Measuring range	$A = -3.300$ to $A = +3.300$
	Linearity	$< 1\%$ for $A \leq 2.000$ in the range 340 to 900 nm
	Accuracy *	$\pm 0.003 A$ for $A < 0.600$ $\pm 0.5\%$ of the reading for $0.600 \leq A \leq 2.000$
	Reproducibility *	$\pm 0.002$ at $A = 1.000$
	Resolution	$\Delta A = 0.001$
	Stray light	$< 0.05\%$ transmission at 340 and 408 nm

\* in the range 200 nm ... 1000 nm

<b>Usable cells</b>	Round cells	<ul style="list-style-type: none"> <li>– Outer diameter: 16 mm</li> <li>– Inner diameter: 13.6 mm</li> <li>– Flat cell bottom</li> </ul>
	Rectangular cells *	<ul style="list-style-type: none"> <li>– Path length: 10 mm, 20 mm and 50 mm</li> <li>– Maximum width: 12.6 mm</li> </ul>
	Minimum filling level	20 mm
	Minimum filling volume	Round cell 16 mm: 4 ml Rectangular cell, 10 mm: 2 ml Rectangular cell, 20 mm: 4 ml Rectangular cell, 50 mm: 10 ml
	Cell recognition	Automatic for most types

- *Suitable are rectangular glass cells with opaque lateral surfaces .  
Plastic cells with clear or serrated lateral surfaces are not reliably recognized by the automatic cell recognition.  
Cells that are not recognized disturb the AutoCheck measurement and, as a consequence, falsify measured values until the next AutoCheck is carried out.*

**Warm-up time**      At least 15 min for single measurements  
 2 h for kinetic measurements with the highest possible precision



**Note**

Changes or modifications not expressly approved by the manufacturer could void the user's authority to operate the equipment.

**Measuring modes**

- Concentration
  - Measurement with permanently programmed methods, adapted to the WTW test set program
  - Automatic method selection if test sets with barcodes are used
  - Program support for the creation of additional user-defined methods (max. 100)
  - Citation forms and units method dependent
  - Display of the absorbance value can be added
  - Method data update possible via Internet

- Absorbance / % Transmission
  - Measurement against own reference absorbance value possible
- Multi wavelengths
  - Freely definable calculations from absorbance values at up to 10 different wavelengths
  - Calculations can be stored as methods (max. 499)
- Measuring modes**
  - Spectrum
    - Absorbance or % transmission mode
    - Limits freely selectable within the wavelength range
    - Increment: 1 nm
    - Recording duration for the complete wavelength range: < 7 min
    - Settings can be stored as profiles (max. 20)
    - Evaluation functions: Cursor scanning, zoom, min./max. recognition, peak area determination, derivation, smoothing, multiplication by constants, addition of constants, addition and subtraction of spectra, formation of the quotient of two spectra
  - Kinetics
    - Absorbance or % transmission mode
    - Minimal adjustable scan interval: 1 s (if the absorbance of the test sample is high, the scan interval is extended due to the longer duration of the individual measurements)
    - Settings can be stored as profiles (max. 20)
    - Evaluation functions: Cursor scanning, zoom, min./max. determination, slope calculation (for an interval or total), enzymatic activity
  - OptRF
    - Measurement with permanently programmed methods for which no test sets are required
    - Citation forms method dependent



## 7.2 Measured value documentation and quality assurance

<b>Memory for measured values</b>	Memory capacity	<ul style="list-style-type: none"> <li>– 5000 single measured values from the measuring modes: concentration, absorbance / % transmission and multi wavelengths</li> <li>– 40 MByte internal memory, sufficient for approx. 500 spectra and 400 kinetic curves (sample values based on the following assumptions: All spectra over a wavelength range of 600 nm and all kinetic curves with 150 single values each)</li> </ul>
	Output options	USB medium, printer, PC
	File formats	ASCII, *.csv
<b>Monitoring functions</b>	AQA1	Check of the photometer
	AQA2	Check of the total system
	AQA3	Check of the sample matrix
<b>User management</b>	Can be switched off	yes
	User accounts	3 hierarchical levels (administrator, user, guest)
	Password protection	for administrators and users

## 7.3 General meter data

<b>Dimensions</b>	404 x 197 x 314 mm (width x height x depth)
<b>Weight</b>	approx. 4.5 kg (without plug-in power supply)
<b>Housing type of protection</b>	IP 30
<b>Electrical protective class</b>	III
<b>Test mark</b>	CE

<b>Allowed environmental conditions</b>	Temperature	Operation: +10 °C to + 35 °C (41 °F to 95 °F) Storage: -25 °C to + 65 °C (-13 °F to 268 °F)
	Humidity	Yearly mean: ≤ 75 % 30 days/year: 95 % Other days: 85%
	Climatic class	2
<b>Power supply</b>	Power pack	Type: EDACPOWER EA1036R Input: 100 - 240 V ~ / 50 - 60 Hz / 1 A Output: 12 V = / 3 A
<b>Guidelines and norms used</b>	EMC	EC directive 2004/108/EC EN 61326-1 – Interference emission: Class B – Interference immunity: IEC 61000-4-3 – Tolerance extension: 0.008 E FCC Class A
	Instrument safety	EC directive 2006/95/EC EN 61010-1
	Climatic class	VDI/VDE 3540
	IP protection	EN 60529
<b>Communication interfaces</b>	Ethernet	RJ45
	USB	– 1 x USB-A (for printer, USB media, keyboard or bar code reader) – 1 x USB-B (for PC)
<b>Other features</b>	<ul style="list-style-type: none"> <li>● Drain for spilled cell contents</li> <li>● Photometer software update and method data update possible via Internet</li> </ul>	



# Xylem |'zīləm|

- 1) The tissue in plants that brings water upward from the roots;
- 2) a leading global water technology company.

We're 12,500 people unified in a common purpose: creating innovative solutions to meet our world's water needs. Developing new technologies that will improve the way water is used, conserved, and re-used in the future is central to our work. We move, treat, analyze, and return water to the environment, and we help people use water efficiently, in their homes, buildings, factories and farms. In more than 150 countries, we have strong, long-standing relationships with customers who know us for our powerful combination of leading product brands and applications expertise, backed by a legacy of innovation.

**For more information on how Xylem can help you, go to [www.xylem.com](http://www.xylem.com)**



## **Wissenschaftlich-Technische Werkstätten GmbH**

Dr.-Karl-Slevogt-Straße 1  
D-82362 Weilheim  
Germany

Tel: +49 881 183-0  
Fax: +49 881 183-420  
E-Mail: [info@wtw.com](mailto:info@wtw.com)  
Internet: [www.wtw.com](http://www.wtw.com)