

Artikelnummer Betriebsanleitung: 1520 9001
Article no. operating instructions:

PFEUFFER

Operating Instructions

Laboratory mill Milomat



Pfeuffer GmbH
Flugplatzstraße 70
97318 Kitzingen
GERMANY
Phone: +49 9321 9369-0
info@pfeuffer.com
www.pfeuffer.com

Revision 1.1/21.01.2021
Translation of the original operating instructions



These Operating Instructions are a constituent part of the MILOMAT laboratory mill and must be available to all operating personnel at all times. They are intended for the operating company of the system, the operating personnel and the specialists who are responsible for the transport, assembly, installation, operation, maintenance, cleaning, disassembly and disposal.

The Pfeuffer GmbH has prepared and reviewed these Operating Instructions with the greatest care. However, no guarantee is made for its completeness or accuracy.

Subject to technical modifications.

Translation

If the system is being supplied or subsequently sold to countries of the EEA, the Operating Instructions must be translated into the language of the country of use accordingly.

If there are any discrepancies with the translated text, then use the original Operating Instructions (German version) or contact the manufacturer.

Operating Instructions in electronic format

PDFs of the original Operating Instructions (German version) and translations of the original Operating Instructions can be requested by e-mail: doku@pfeuffer.com

Ensure the correct type designation and serial number is stated!

© Copyright

The passing on or reproduction of this document, and use and disclosure of its contents are prohibited unless expressly permitted. We will claim compensation for damages. All rights reserved with regard to the granting of patents, utility models or designs.

(DIN ISO 16016)

1	Introduction	4
1.1	Intendend use.....	4
1.2	Declaration of conformity	5
1.3	Design characteristics of hazard warnings.....	6
1.4	Pictograms in the Operating Instructions	6
1.5	Abbreviations in electrical engineering.....	7
1.6	Designation.....	7
2	Safety	8
2.1	Installed safety systems	8
2.1.1	Mains disconnecter in a portable device	8
2.1.2	Protective covers	8
2.1.3	Safety switch.....	9
2.2	Operating and danger areas.....	9
2.3	Operating and maintenance personnel	10
2.4	Safety measures (to be carried out by the owner)	10
2.5	General safety notes	11
2.6	Safety tests	12
2.7	Residual dangers in connection with the MILOMAT	12
2.8	Switch-off procedure.....	12
3	Technical data	13
3.1	Dimensions and weight	13
3.2	Power supply	13
3.3	General data.....	13
4	Delivery, transport and storage	14
4.1	Scope of delivery	14
4.2	Transport and packaging.....	14
4.3	Intermediate storage.....	14
4.4	Transport to the installation site (by the customer)	15
5	Installation and commissioning	15
6	Function	16
6.1	Overview	16
6.2	Sequence of functions.....	16
7	Operation	17
7.1	Sample preparation.....	17
7.2	Carrying out a milling process.....	17
7.3	Milling process of inhomogeneous milling material with a sample dividing cup (option)	20
8	Maintenance and cleaning	21
8.1	Cleaning	21
8.2	Inspection interval and function test	22
8.3	Working inside the housing.....	22
8.4	Opening the housing	23
8.5	Changing the V-belt.....	26
8.6	Changing the impact wheel.....	28
8.7	Changing the outlet.....	29
8.8	Checks.....	29
9	Malfunctions – causes and rectification	30
10	Spare parts and accessories	31
11	Emergency	32
12	Dismantling and disposal	32

1 Introduction

1.1 Intendend use

The laboratory mill MILOMAT is used to mill agricultural cereals. The impact mill is perfect for pre-crushing and fine crushing from soft to medium-hard products. Even dry and tough samples can be milled without difficulties.

The milling material is used for the moisture determination with the Pfeuffer moisture meter HE 60 and HE 90.

The outlet nozzle of the MILOMAT is therefore adapted to the measuring cells of these two moisture meters. The MILOMAT should only be operated with a measuring cell under the outlet nozzle. During the milling process, strong air flows and heating are avoided in order not to influence the actual moisture content. The MILOMAT is therefore used for the sample preparation and to be seen as accessory for the moisture meter.

The MILOMAT is designed as a portable machine with a power plug for interiors. The laboratory mill may not be used as a production machine or put into continuous operation.

Private use of the MILOMAT laboratory mill is prohibited.

NOTE

The MILOMAT laboratory mill was designed solely for the aforementioned purpose.

Using it for any other purpose or modifying it without the written consent of the Pfeuffer GmbH is not considered to be in compliance with the intended use.

The Pfeuffer GmbH shall not be liable for the resulting damage. Damage caused by such an unintended use is at the sole risk of the operator.

The MILOMAT is allowed to be operated only if it is ensured that all the safety devices are functional.

The MILOMAT may not be used for milling material containing solid and massive objects made of metal, stone, concrete, plastic or other foreign components.

The MILOMAT is not suitable for liquid and sticky products.

The samples to be used for the correct operation of the MILOMAT are provided by the operator.

The operator bears sole responsibility for the proper handling of these materials and the associated dangers.

Hazard notes and instructions for disposal must be provided by the operator.

Intended use includes also the compliance with the Instruction Manual and User's Guide as well as the maintenance and servicing conditions, as specified in these Operating Instructions.

These Operating Instructions do not relieve the operating company of the obligation to develop and to apply independent health and/or safety regulations or safe working processes which are aimed at the requirements of the overall machine, as well as the obligation to monitor their compliance.

1.2 Declaration of conformity**EC/EU Declaration of conformity**

in terms of the directives
 machinery 2006/42/EC and electromagnetic compatibility 2014/30/EU

Manufacturer: **Pfeuffer GmbH**
 Flugplatzstraße 70
 97318 Kitzingen
 GERMANY

Person authorized to compile technical documents: **Lothar Pfeuffer, General Manager**

Product: **Milomat** laboratory mill

Serial number: _____

The product mentioned above fulfils the requirements of the following applicable directives and standards:

Directive / Standard	Title
2006/42/EG	EC-directive: machinery
DIN EN ISO 12100:2010	Machine safety – General principles for design – Risk assessment and risk reduction
DIN EN 60204-1:2006	Machine safety; electrical equipment of machines; part 1: General requirements
2014/30/EU	EU-directive: electromagnetic compatibility
DIN EN 61000-6-2:2006	Electromagnetic compatibility – Part 6-2: Generic standards - Immunity standard for industrial environments
DIN EN 61000-6-3:2007	Electromagnetic compatibility – Part 6-3: Generic standards – Emission standard for residential, commercial and light-industrial environments

This declaration shall become null and void should any alterations be made to the MILOMAT laboratory mill without our approval.





Kitzingen, _____

 Lothar Pfeuffer, General Manager









1.3 Design characteristics of hazard warnings

The Pfeuffer GmbH Operating Instructions contain information which must be observed for the sake of your personal safety and to avoid damage to property. Information concerning your personal safety is shown by means of a triangle.

Note the following categories of hazard warnings and explanation of symbols:

Pictogram 	 SIGNAL WORD
	Type of hazard and its source. Possible result of its disregard. ⇒ Measure to ward off the hazard.
 DANGER	
warns against a very dangerous situation that results in death or serious injuries.	
 WARNING	
warns against a dangerous situation that can potentially result in death or serious injuries.	
 CAUTION	
warns against a potentially dangerous situation that results in minor or moderate injuries.	
NOTE	warns against situations that are dangerous for the product and/or the environment.

1.4 Pictograms in the Operating Instructions

	Remarks of special importance and/or additional information		Warning
	Follow the Operating Instructions		Warning – Electrical Voltage
	Pull the mains plug		Warning – Hand injuries
	Use hand protection		Warning – Hot surfaces
	Earth conductor		

1.5 Abbreviations in electrical engineering

Color abbreviations for the individual strands (conductors) of a cable according to DIN IEC 60757:

Color	Color abbreviations	Color	Color abbreviations
Black	BK	Violet	VT
Brown	BN	Gray	GY
Red	RD	White	WH
Orange	OG	Pink	PK
Yellow	YE	Turquoise	TQ
Green	GN	Green-yellow	GNYE
Blue	BU		

Conductor designations according to DIN VDE 0293-308:

L	Live conductor, phase (outer conductor)	Color abbreviations
L1	Outer conductor 1	BN
L2	Outer conductor 2	BK
L3	Outer conductor 3	GY
N	Neutral conductor	BU
PE	Protective earth conductor	GNYE

1.6 Designation

The information provided in these Operating Instructions applies only for the machine whose type designation is specified on the title page.

The identification plate with the type designation is located on the machine housing (rear wall).

Correct information of type designation, serial number and year of manufacture is important for all queries. This ensures fast processing.

Example of a Pfeuffer GmbH identification plate:



2 Safety

NOTE It is strictly prohibited to deactivate the safety devices or modify their mode of effect.

2.1 Installed safety systems

The installed safety systems must be checked with corresponding test methods at regular testing intervals; refer to the following table:

Test intervals	Test methods
d = daily	VI = visual inspection
w = weekly	FT = functional test
m = monthly	M = measurement
¼ y = quarterly	
½ y = half-yearly	
y = yearly	

2.1.1 Mains disconnecter in a portable device

The main switch **I/O** is the mains disconnecter, and also serves as the EMERGENCY OFF function. It is located on the front of the device.

Test	
Interval	Method
m	FT

The plug connection for the mains cable (C19/C20 coupler) is located at the rear panel (see figure 1).



- ⇒ In an emergency, switch off the MILOMAT using the main switch, position **0**.
- ⇒ Disconnect the mains cable from the electrical power supply, or pull out the coupler.
- ⇒ Secure the mains cable appropriately against unauthorized reconnection by placing it where it can be monitored continuously.



Arrange the plug/socket combination at the place of installation so that it can be observed clearly and reached quickly in an emergency.

2.1.2 Protective covers

During the operation, laboratory mill MILOMAT is protected against interference affecting the machine using protective covers.

Test	
Interval	Method
m	VI

2.1.3 Safety switch

For protection of the motor and the setting the following safety switches have been installed:

Thermal overcurrent protection switch

The motor of the MILOMAT laboratory mill is protected by a thermal overcurrent protection switch, which interrupts the motor circuit when the device is overloaded.

Test	
Interval	Method
see DGUV regulation 3	

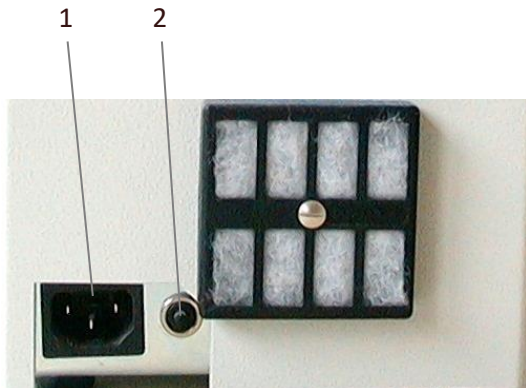

- ⇒ To restart the MILOMAT, allow the motor to cool down sufficiently (approximately 10 minutes).
- ⇒ Then press the black reset button (item 2) on the rear panel.

Figure 1: Rear panel MILOMAT laboratory mill

Item	Designation
1	Plug connection
2	Reset button

Micro switch

The cover of the milling chamber is protected by two micro switches. These prevent opening during operation and starting with open milling chamber.

Test	
Interval	Method
See DGUV regulation 3	

2.2 Operating and danger areas

Operating area

Make sure the installation height is sufficient (according to the stature of the operating personnel). A suitable base (e. g. table) is required for this.

Danger area

The entire area one meter around the MILOMAT is a danger area during maintenance and repair work. Keep the area around the MILOMAT clear of objects.

2.3 Operating and maintenance personnel

Operating and maintenance personnel are people who are responsible for transport, assembly, installation, operation, setup and cleaning of the MILOMAT, and for eliminating malfunctions.

1. The MILOMAT is only allowed to be operated by authorized and instructed people.
 2. The responsibilities for operating the MILOMAT must be clearly defined and complied with so that no unclear competencies arise with regard to the aspect of safety.
 3. The switch-off procedures specified in the operating instructions must be complied with during all work (operation, maintenance, repair, etc.), see **chapter 2.8**.
 4. The operator must refrain from any working method that impairs safety on the MILOMAT.
 5. The owner must ensure that only authorized people work on the MILOMAT.
 6. The owner is obliged to report immediately to the owner any changes that take place on the MILOMAT which impair safety.
 7. The operating personnel must be provided by the owner with appropriate protective equipment in accordance with legal requirements and the material to be processed.
1. The owner must issue regular instructions regarding the use of personal protective equipment, and must check such equipment is being used.

2.4 Safety measures (to be carried out by the owner)

It should be noted that the owner is responsible for the following aspects with regard to the operating and maintenance personnel

- ⇒ Providing instruction in the protective devices for the MILOMAT
- ⇒ Monitoring compliance with the safety measures.

The frequency of the function tests described in **chapter 8.2** must be complied with. The work described in these operating instructions is configured in such a way that

- ⇒ it is explained in the chapters Function and Operation for the operating personnel
- ⇒ it is explained in the chapters Delivery, Transport and storage, Installation and commissioning, Maintenance and cleaning, Malfunctions – causes and rectification and Dismantling and disposal for a specialist operator.

The chapters Delivery, Transport and storage, Installation and commissioning, Maintenance and cleaning, Malfunctions – causes and rectification and Dismantling and disposal are **only intended for specialist operators**. Work described in this chapter is only to be carried out by **specialist operators**.

Instructed person

A person who has been instructed and, if necessary, trained by a **specialist operator** regarding the tasks assigned to him/her and the possible dangers in the event of incorrect conduct, and who has also been instructed regarding the necessary protective devices and protective measures.

Specialist operator

An individual who, due to his/her relevant specialist training and/or experience, is capable of recognizing risks and avoiding dangers that may occur during use of the product.

(Definition according to DIN EN 82079-1:2013-06)

Obligations of the operator



In the European Economic Area (EEA), national implementation of the framework directive 89/391/EEC and corresponding individual directives, in particular the directive 2009/104/EC "concerning the minimum health and safety requirements for the use of work equipment by workers at work", as amended, are to be observed and adhered to.

In addition, he/she must comply with the local legal requirements on:

- ⇒ Safety of personnel (accident prevention regulations)
- ⇒ Accident prevention regulation DGUV Regulation 3 (previously BGV A 3) "Electrical systems and equipment" (DGUV = Association of German Statutory Accident Insurance)
- ⇒ Safety of work equipment (protective equipment and maintenance)
- ⇒ Permitted noise load (depending on the site and time of day)
- ⇒ Product disposal (waste legislation)
- ⇒ Material disposal (waste legislation)
- ⇒ Cleaning (cleaning agents and disposal)
- ⇒ Hazardous substances (in Germany, the technical rules for hazardous substances – TRGS 555 apply)
- ⇒ Environmental protection regulations.

Electrical connections



The MILOMAT is only allowed to be connected to a socket earthed in accordance with the regulations, using a protective conductor.

Illuminance



The owner must ensure that there is adequate and homogeneous illumination in all areas. At least 300 lux is recommended (maintained illuminance).

In Germany, ASR A3.4 applies (technical rules for workplaces - lighting).

2.5 General safety notes



The safety equipment and safety notes described in these operating instructions must be complied with.



1. Disconnect the MILOMAT from the mains if there are malfunctions.
2. Disconnect the MILOMAT from the mains before cleaning work.
3. Do not allow the MILOMAT to get wet during transport, storage, cleaning and operation.
4. Make sure that the MILOMAT is only operated when in correct working order.
5. Never touch the mains cable with moist hands.
6. Only use genuine spare parts and accessories (see **chapters 10**).

2.6 Safety tests

Pfeuffer GmbH carried out the following safety tests at the factory:

Testing and checking according to DIN EN 60204-1:

- Check that the electrical equipment is in compliance with the technical documentation.
- Continuous connection of the protective earth system
- Insulation resistance tests
- Voltage tests
- Protection against residual voltages
- Function tests

The functions of the electrical equipment, in particular those relating to safety and protective measures, have been tested.

2.7 Residual dangers in connection with the MILOMAT

⇒ During all work on electrically operated components, pay attention to dangers from electrical current.

2.8 Switch-off procedure



DANGER

Touching live parts can be fatal!

It is essential to comply with the following switch-off procedure prior to cleaning, maintenance or repair work (only by specialist personnel):

- ⇒ Empty the MILOMAT laboratory mill.
- ⇒ Switch off the MILOMAT using the main switch, position **0**.



⇒ Disconnect the mains cable from the electrical power supply, or pull out the coupler.

- ⇒ The mains cable must be able to be kept under the direct supervision of the person in the danger area.
- ⇒ During cleaning, make sure that no water, steam or dust can penetrate the electronics area.

3 Technical data

MILOMAT	Laboratory mill
Sample amount	0.02 liters
Products	Cereals, maize, sunflower seeds, beans, peas and seeds

3.1 Dimensions and weight

Height	300 mm
Width	160 mm
Length	280 mm
Weight	10 kg

3.2 Power supply

Operating voltage/ frequency	230 V _{AC} , 50 Hz
Power consumption	70 VA
Number of phases	1-ph / PE
Protective earth conductor	PE (yellow/green) in the mains cable
Internal fuse	315 mA slow-blow glass microfuse 5x20 mm
Mains cable	With removable supply cable (C19/C20 coupler); 10 A, 250 V
Installation regulation	Configured according to VDE

3.3 General data

Ambient temperature storage and transport	-10 °C to +60 °C
Ambient temperature in operation	+15 °C to +40 °C
Atmospheric humidity	20 % – 80 % non-condensing

4 Delivery, transport and storage



The Delivery, transport and storage chapter is only intended for **specialist operators**.

4.1 Scope of delivery

The standard scope of delivery to the owner comprises:

1. MILOMAT laboratory mill
2. Mains cable with removable connection (C19/C20-coupler)
3. Cleaning brush
4. Operating Instructions

Article numbers are shown in **chapter 10**.

4.2 Transport and packaging

Systems, machines and devices from Pfeuffer GmbH are carefully tested and packaged prior to dispatch, however it is not possible to exclude the risk of damage during transport.

Incoming check

Check for completeness with reference to the delivery note.

In case of damage

Check the delivery for damage (visual inspection).

In case of complaints

If the delivery suffered damage in transit:

- ⇒ Keep the packaging (to allow it to be checked subsequently by the forwarding company, or for sending back).
- ⇒ Immediately inform the supplier or Pfeuffer GmbH.

4.3 Intermediate storage

The freight packaging of the MILOMAT and the accessory/replacement parts is configured for a storage duration of up to six months from delivery.

- ⇒ Do not place any heavy objects on the packaging.

Storage conditions

Enclosed, dry room with a room temperature between min. -10 °C and max. +60 °C.

4.4 Transport to the installation site (by the customer)



The transport is only allowed to be undertaken by specialist personnel according to the local conditions and any information indicated on the packaging material.

Unpacking

To avoid damage to the housing and other components,

- ⇒ open the packaging
- ⇒ remove the packaging elements
- ⇒ lift the MILOMAT carefully out of the box
- ⇒ note that the unit weighs 10 kg
- ⇒ move the MILOMAT to the installation location.

Keep the original packaging in case you need to send the equipment back.

Packaging for return delivery

- ⇒ If possible, use the original packaging and the original packaging material. If neither is available any longer, request new packaging from Pfeuffer GmbH.

5 Installation and commissioning



The installation and commissioning chapter is only intended for **specialist operators**.

Installation

- ⇒ Carefully unpack the laboratory mill MILOMAT (see **chapter 4.4**).
- ⇒ Place the MILOMAT level on a solid table with a smooth and clean surface.
- ⇒ Make sure there is an adequate distance to all sides so that no heat buildup can occur.
- ⇒ Do not set up the MILOMAT close to apparatus/devices that are sensitive to dust.
- ⇒ Avoid exposure to direct sunlight and extreme ambient conditions.
- ⇒ Make sure that the installation height is ergonomic according to the stature of the operating personnel.
- ⇒ Connect the supplied mains cable to the MILOMAT using the connector (C19/C20 coupler).



- ⇒ Connect the plug of the mains cable to a suitably earthed socket with protective earth conductor.

- ⇒ Take the MILOMAT into operation according to the instructions in **chapter 7**.

6 Function

6.1 Overview

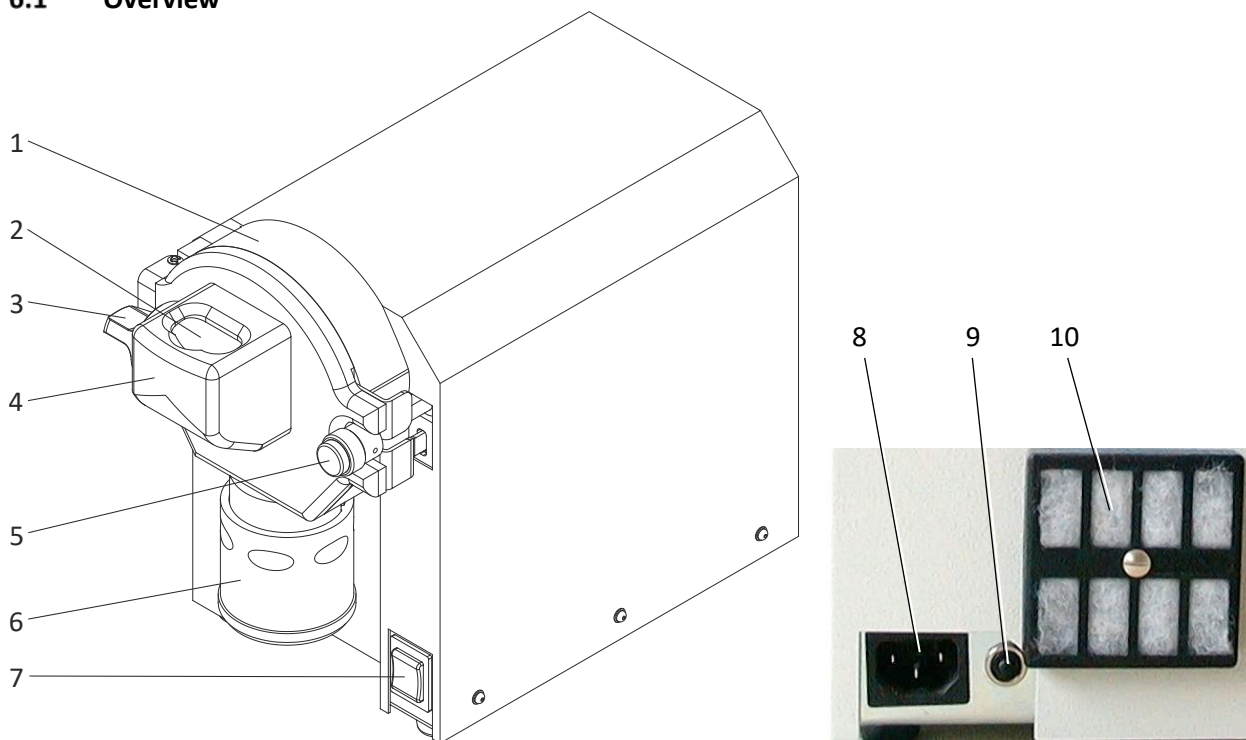

Figure 2: Overview MILOMAT laboratory mill

Rear panel

Item	Designation	Item	Designation
1	Milling chamber with cover	6	Outlet
2	Filling hopper	7	Main switch (I/O)
3	Dosing knob	8	Plug connection
4	Dosing feed	9	Reset button (Overcurrent protection switch)
5	Locking spindle	10	Air filter

6.2 Sequence of functions

The laboratory mill MILOMAT is an impact mill for agricultural cereals. Fill a measuring beaker (0.02 l, accessory moisture meter HE 60/90) with the cleaned sample. Place the contents in the filling hopper. The product trickles into the milling chamber by rotating the dosing knob. The product is smashed between a standing and a rotating metal pin collar (impact effect). The milling material falls into the bottom part of the measuring cell of the moisture meter HE 60/90 via the outlet nozzle.



For precise information about operation, refer to **chapter 7**.

For detailed information on the product quantity and the measuring method, please refer to the respective Operating Instructions of the moisture meter HE 60/90.

7 Operation



The MILOMAT laboratory mill is only allowed to be operated by personnel who have been qualified and trained in its operation.

7.1 Sample preparation

NOTE Foreign bodies must be removed prior to the milling!

⇒ Select a **representative** and **cleaned sample** for the milling.

Larger products (e. g. large bean seeds) can damage the MILOMAT!

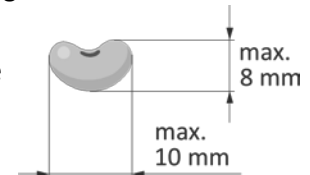

Figure 3:
Maximum grain size

7.2 Carrying out a milling process



Figure 4: Close the cover

- ⇒ Close the cover of the milling chamber.
- ⇒ Pull the locking spindle forward and swing it to the left over the tab.



Figure 5: Put on outlet nozzle

- ⇒ Place the bottom part of the measuring cell of the moisture meter HE 60/90 under the outlet.
- ⇒ Push the outlet nozzle downwards on the bottom of the measuring cell by turning it about 20 ° to the left. The sealing rubber must rest on the measuring cell rim. The integrated spindle protection prevents the spindle from being soiled.



Figure 6: Switch on the MILOMAT

- ⇒ Switch on the MILOMAT by pressing the main switch, position **I**.
The motor starts and the impact wheel turns.
- ⇒ Wait, until the MILOMAT has reached their speed after some seconds.



Figure 7: Fill in product

- ⇒ Fill in a measuring beaker (0.02 l) into the filling hopper.



Figure 8: Empty filling hopper

- ⇒ Slowly turn the dosing knob on the dosing feed backwards until the filling hopper is completely emptied.
- ⇒ Let the MILOMAT run until all grains are milled.
- ⇒ Switch off the MILOMAT by pressing the main switch, position **0**.
- ⇒ Wait for the shutdown of the MILOMAT.



Figure 9: Open milling chamber

- ⇒ Open the milling chamber by swinging the locking spindle.



Figure 10: Clean milling chamber

- ⇒ Clean the milling chamber and the outlet with the supplied cleaning brush.
- ⇒ Close the cover of the milling chamber.



Figure 11: Push the outlet upwards

- ⇒ Push the outlet nozzle upwards.
- ⇒ Fix the outlet by turning it briefly to the upper right.



Figure 12: Remove bottom part of the measuring cell

- ⇒ Remove the bottom part of the measuring cell.



For detailed information on the product quantity and the measuring method, please refer to the respective Operating Instructions of the moisture meter HE 60/90.

⚠ CAUTION

Overheating hazard!



The laboratory mill may not be used as a production machine or put into continuous operation!

- ⇒ To avoid bending the metal pins in the milling chamber, allow the MILOMAT to cool down sufficiently after each milling.

7.3 Milling process of inhomogeneous milling material with a sample dividing cup (option)

The sample dividing cup is used to increase the measuring accuracy by using a larger sample quantity. We recommend the use of the sample dividing cup especially for sample preparation for the moisture determination of humid maize.

For products where a moisture balance has already taken place (through storage), there is no improvement for the measurement result.



Figure 13: Sample dividing cup

- ⇒ Instead of one measuring beaker, mill for **maize** two measuring beaker (2 x 0.02 l) of the sample. Then divide the sample halfway through the sample dividing cup. This results in an average pattern.
- ⇒ Pull out the separating sheet completely.
- ⇒ Place instead of the bottom part of the measuring cell the sample dividing cup under the outlet of the MILOMAT.
- ⇒ Push the outlet nozzle downwards.
- ⇒ Carry out the milling process with two filled measuring beaker, as described in **chapter 7.2**.
- ⇒ Push the outlet nozzle upwards after the milling process has finished.



Figure 14: Place the sample dividing cup under outlet

- ⇒ Remove the sample dividing cup.
- ⇒ Mix the sample thoroughly with the stirring rod.
- ⇒ Straighten the sample surface by gently shaking.
- ⇒ Insert the separating sheet into the guide of the sample dividing cup. This divides the sample into two equally sized halves.



Figure 15: Fill in the sample into the bottom part of the measuring cell

- ⇒ Then fill in the sample into the bottom part of the measuring cell and carry out a measurement in accordance with the Operating Instructions for the moisture meters HE 60/90.
- ⇒ The second half of the sample remaining behind the separating sheet can then be used for further measurements.

8 Maintenance and cleaning



The Maintenance and cleaning chapter is only intended for **specialist operators**.

NOTE

Opening the housing and inappropriate operation will invalidate the warranty.

To ensure trouble-free operation, it is essential for the MILOMAT to be cleaned and maintained at regular intervals.

! DANGER



Touching live parts can be fatal!

It is essential to comply with the switch-off procedure before cleaning, maintenance or repair work! (See **chapter 2.8**)

- ⇒ During all work that is required, wear personal protective equipment according to the company health and safety regulations.
- ⇒ Pay attention to local statutory accident prevention regulations!



The times for carrying out cleaning and maintenance work are based on one-shift working (8 hour/day, 22 days/month, 12 months/year).

- d** = Daily **¼ y** = Every three months
- w** = Weekly **½ y** = Every six months
- m** = Monthly **y** = Every year

8.1 Cleaning

NOTE

Do not use any sharp objects or tools for cleaning. Only use objects that are expressly intended for this purpose.

During cleaning work, wear personal protective equipment according to the company health and safety regulations.

During cleaning, make sure that no water, steam or dust can penetrate the electronics area.

Cleaning	Rectification	Interval
Housing surface	With a clean, dry and lint-free cloth. Clean with a damp cloth in case of heavy contamination.	w
Milling chamber and pen ring in the cover	With the included cleaning brush.	After each milling
Filling hopper	With the included cleaning brush.	After each milling
Outlet	With the included cleaning brush.	After each milling

Renewing the air filter

The air filter at the backside of the housing has to be cleaned depending on the environmental conditions.

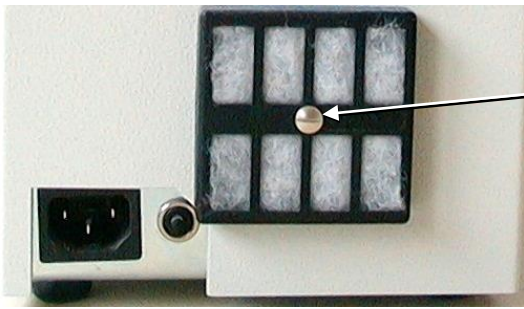

- ⇒ Turn the slotted screw a quarter turn to remove the air filter housing.
- ⇒ Renew the air filter.

Figure 16: Rear panel air filter

8.2 Inspection interval and function test

Sub-assembly	Interval in one-shift working				
	w	m	¼ y	½ y	y
Normal function test					
Main switch 0/I		X			
Locking spindle for tight fit				X	
Metal pins in the cover and on the impact wheel for breakage and wear				X	
Mains cable and connection					X
Labels and warning notes in place and legible (by visual inspection)					X
Electrical safety switches	See DGUV regulation 3				
Electrical test according to VDE	See DGUV regulation 3				

8.3 Working inside the housing

NOTE

The warranty offered by Pfeuffer GmbH will be invalidated if the housing is opened. **Pfeuffer GmbH expressly points out that fitting spare parts and renewing wearing parts are procedures which require a certain level of experience!** This work should only be carried out by a **specialist** if it is not possible to send the MILOMAT to Pfeuffer GmbH customer service.

 **DANGER**



Touching live parts can be fatal!

It is essential to comply with the switch-off procedure before cleaning, maintenance or repair work! (See **chapter 2.8**)

The owner-operator must then ensure that a safety check is carried out according to DIN VDE 0701-0702 before the MILOMAT is taken back into operation.



⚠ CAUTION

Cutting injuries to hands and fingers!

The sheet metal parts of the housing may have sharp corners and edges.

⇒ Wear protective gloves.



Burns to hands and fingers!

The motor temperature increases during operation, reaching in excess of 40 °C!

⇒ Allow the MILOMAT (motor) to cool down adequately after operation, or wear protective gloves.



NOTE

Keep all screws and removed small parts carefully.

Metallic housing parts must be connected to the protective earth conductor.

In this connection, make sure that

- all original parts are reinstalled in the location intended for them. No excessively long screws are used, since these can cause short circuits or damage components inside the housing.
- all grounding cables are reconnected and all screws are firmly tightened.

Tools and equipment

Before you start assembly, prepare the following tools and equipment:

- Phillips screwdriver
- Screwdriver for straight screws
- Hexagon screwdriver 2 mm, 4 mm
- Pair of pliers or flat nose pliers

8.4 Opening the housing



⇒ Open the milling chamber.

⇒ Remove the yellow cap on the turning knob of the locking spindle.

Figure 17: Remove cap on the locking spindle



Figure 18: Loosen the turning knob

- ⇒ Loosen the countersunk screw M2,5x12 mm.
- ⇒ Pull off the turning knob with the spring retainer and the pressure spring from the locking spindle.

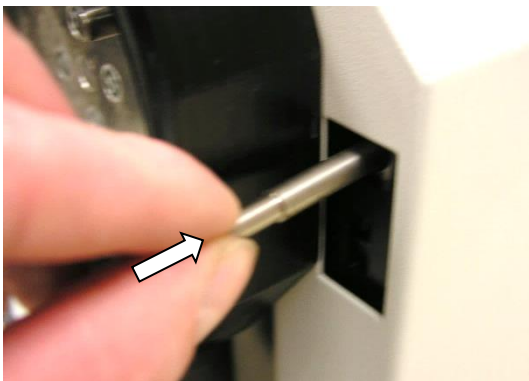

Figure 19: Push the locking spindle inwards



- ⇒ Push the locking spindle inwards until it does not stick out of the housing anymore.

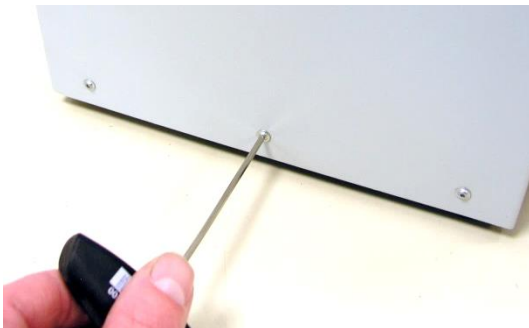
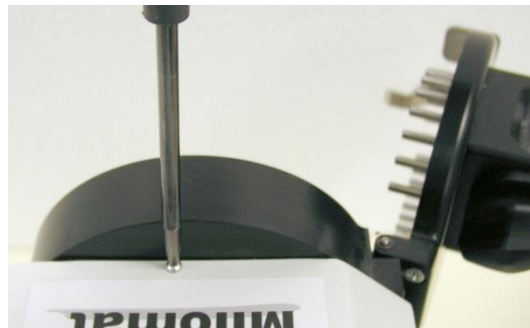

Figure 20: Open housing



- ⇒ Unscrew the 7 housing mounting screws (three clamping flange screws M3x8 mm on the sides and a lens head screw on the top).

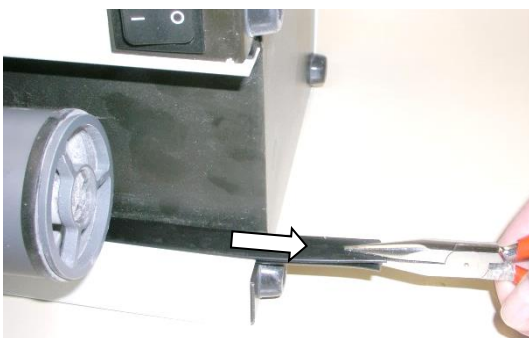

Figure 21: Remove sealing profiles

- ⇒ Place the MILOMAT on its side.
- ⇒ Use suitable pliers to pull out both sealing profiles between housing and chassis downwards.

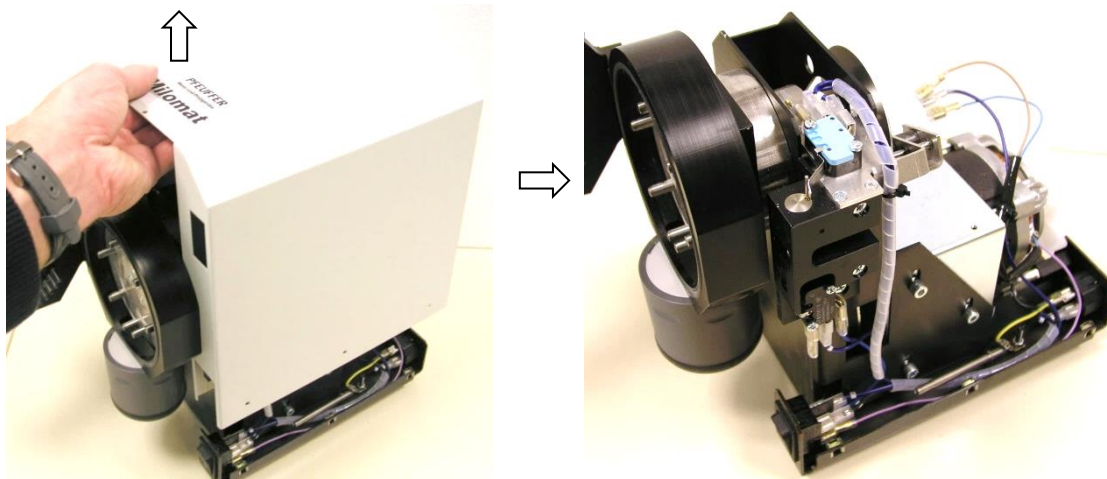

Figure 22: Remove housing

⇒ Replace the MILOMAT and remove the housing.

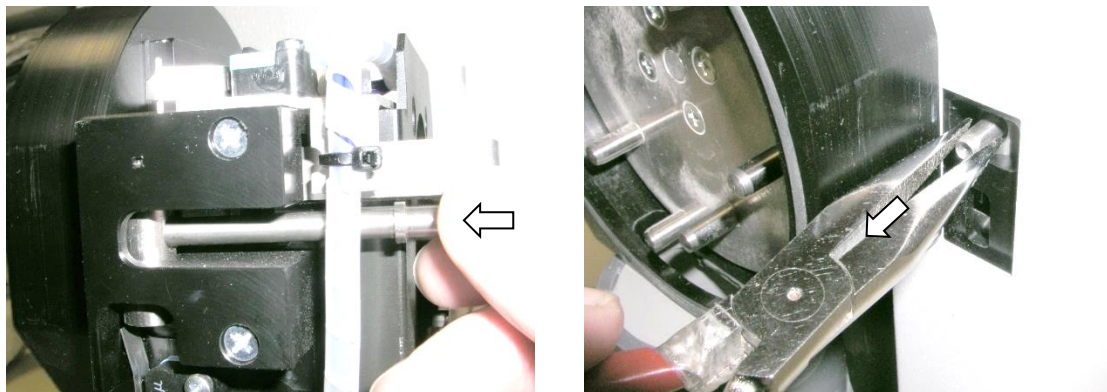

Figure 23: Insert locking spindle

⇒ For the subsequent assembly, insert the loose locking spindle as shown in figure 23 (left) in such a way that it can be pulled out from the front with a suitable pliers, as shown in figure 23 (right).

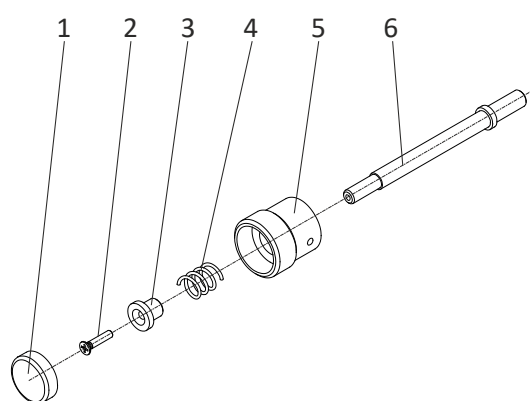

Figure 24: Assembly turning knob to locking spindle

⇒ For the further assembly you perform the steps in reverse order.

Item	Designation	Item	Designation
1	Yellow cap	4	Pressure spring
2	Counter sunk bolt M2,5x12 mm	5	Turning knob
3	Spring holder	6	Locking spindle

8.5 Changing the V-belt



The impact wheel is impelled by a V-belt transmission. The V-belt only has to be changed when it is obviously torn (no function of the MILOMAT despite the start-up of the motor).

Before you start work, pay attention to the instructions in **chapter 8.3**.



⇒ Disconnect the mains cable from the electrical power supply, or pull out the coupler.

NOTE

V-belts must be carefully pre-tensioned.

Insufficient pretension leads to insufficient power transmission and premature wear caused by excessive slip (whistling sound during operation).

Excessive pretension causes an unnecessary elongation on the V-belt and causes a high load on the shaft and motor bearings. The motor does not turn to the nominal speed or takes more time for it.

The belts of the MILOMAT are run in, and their tension is carefully checked before delivery.

⇒ Opening the housing, see **chapter 8.4**.

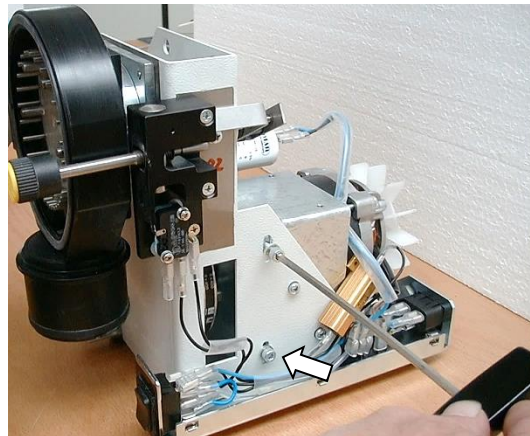
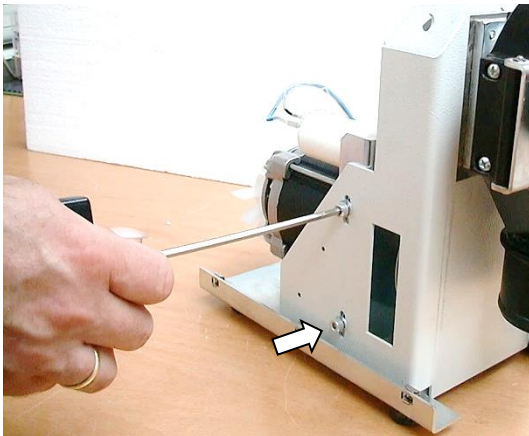
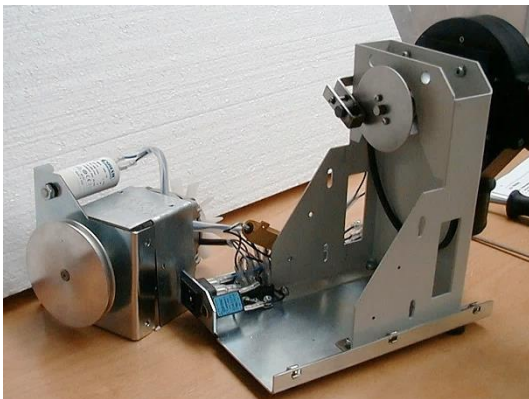

Figure 25: Loosen the screws on the motor plate

⇒ Loosen the four hexagon socket screws M5x16 mm, washers and spring washers on the motor plate.



⇒ Relieve belt tension and take out the motor.

Figure 26: Remove the motor

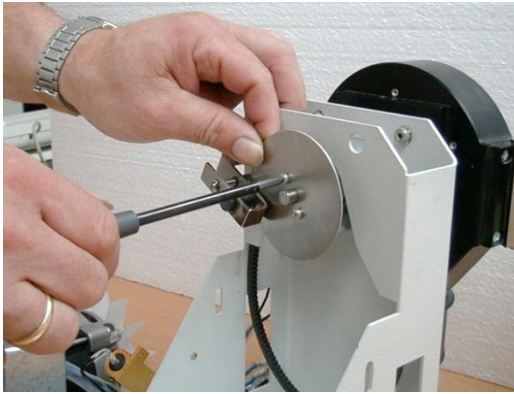

Figure 27: Remove the eddy current disc

- ⇒ Remove the eddy current disc by means of the two lens head screws M3x8 mm and fan discs.



Figure 28: Remove/install the V-belt

- ⇒ Remove the old V-belt.
- ⇒ Install the new V-belt.
- ⇒ Fix the eddy current disc by means of the two lens head screws M3x8 mm and fan discs.

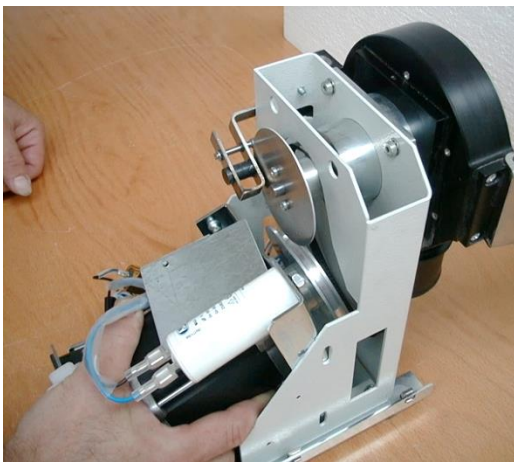

Figure 29: Insert the motor

- ⇒ Insert the motor into the housing by placing it diagonally on the V-belt.
- ⇒ Turn in the 4 motor fixing screws loosely (hexagon socket screws M5x16 mm, washers and spring washers).

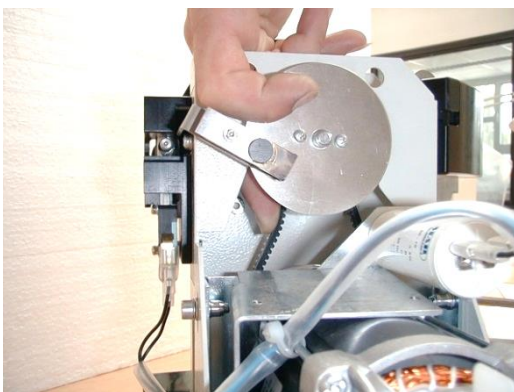

Figure 30: Tension the V-belt

- ⇒ Tighten the V-belt by moving the motor plate downwards. The correct belt tension is reached when the belt can be pushed through approx. 10 mm with low effort.
- ⇒ Tighten the motor fixing screws properly (hexagon socket screws M5x16 mm, washers and spring washers).
- ⇒ Fasten the housing, see **chapter 8.4**.

8.6 Changing the impact wheel



The impact wheel only needs to be changed, when metal pins are broken or deformed. For safety reasons, the impact wheel may only be changed completely!



⇒ Disconnect the mains cable from the electrical power supply, or pull out the coupler.

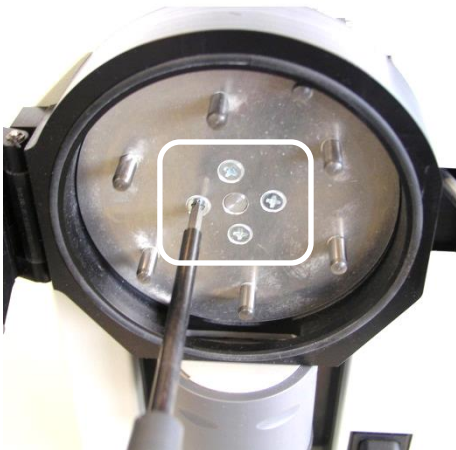

Figure 31: Dismantle the impact wheel

- ⇒ Open the cover of the milling chamber.
- ⇒ Loosen the four countersunk head screws on the impact wheel.
- ⇒ Pull the impact wheel evenly out towards the front.

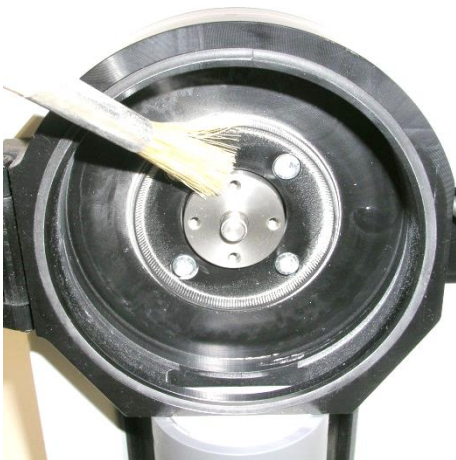
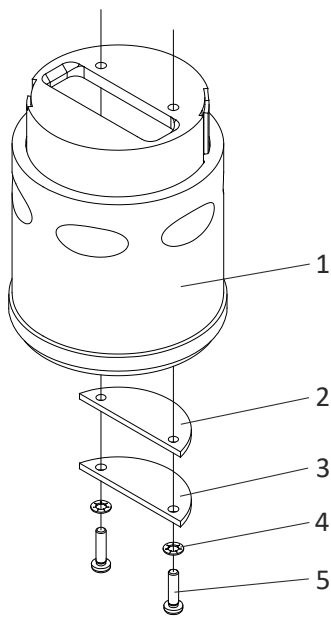

Figure 32: Clean the housing

- ⇒ Clean the housing with a brush.
- ⇒ Insert the new impact wheel.
- ⇒ Fasten it over the four countersunk head screws.

8.7 Changing the outlet



- ⇒ Loosen the two lens head screws (item 5) in the outlet from below.
- ⇒ Remove the outlet.
- ⇒ Fasten the new outlet, see figure 33.

Figure 33: Outlet, complete

Item	Designation
1	Outlet
2	Damping rubber
3	Holding plate
4	Fan washer
5	Lens head screw M3x12 mm

8.8 Checks

At the end of the work, check the following:

- ⇒ The work carried out is complete.
- ⇒ Check the wiring in the housing for kinks, chafing or charred points.
- ⇒ Damage on the covers or insulation.
- ⇒ Check that no tools have been left in or on the machine.
- ⇒ All subassemblies function correctly in setup or manual mode.
- ⇒ If all functions are correct, the machine can be handed over to the owner.

NOTE

Following cleaning, maintenance or exchanging wearing parts, check that all safety devices are functioning correctly.

9 Malfunctions – causes and rectification

The information provided in this chapter about possible malfunctions is structured to be understood by specialists in electrical, electronic or mechanical maintenance.



Appropriate tools and test instruments must be provided to these personnel.

If the specified measures do not prove successful, contact Pfeuffer GmbH.

Correct information of type designation, serial number and year of manufacture is important for all queries. This ensures fast processing.

These information can be found on the type plate on the rear panel of the machine housing.



It is essential to comply with the switch-off procedure before cleaning, maintenance or repair work! (See **chapter 2.8**)

Problem	Cause	Rectification
Motor does not start.	No mains voltage.	Have the mains voltage checked by an electrician and switched on.
	Motor is overheated.	Allow the motor to cool down and then press the black reset button on the rear panel of the MILOMAT.
	MILOMAT blocks, milling material is in the milling chamber before the motor starts.	Switch off the MILOMAT. Remove milling material from the milling chamber. Turn back on the MILOMAT.
	Electrical defective.	Test by Pfeuffer GmbH.
Motor does not start up and hums after switch-on.	Impact wheel blocks due to milling material which was in the milling chamber before switching on.	Clean the milling chamber and check whether the impact wheel can be turned manually.
	Electrical defective.	Test by Pfeuffer GmbH.
Motor runs, but milling material is not milled.	V-belt is not stretched, slipped or torn.	Fastening and renewal by a specialist or by Pfeuffer GmbH, see chapter 8.5 .
Metal pin on the impact wheel broken off.		Replacement of the complete impact wheel by a specialist or by Pfeuffer GmbH, see chapter 8.6 .

10 Spare parts and accessories

NOTE

We wish to point out expressly that replacement and accessory parts not supplied by us will not have been tested and approved by us either. Installing and/or using such products can thus result in the design properties of the MILOMAT laboratory mill being negatively impaired. Pfeuffer GmbH cannot be held liable for damage attributable to the use of non-genuine parts and non-genuine accessories.

Standard parts can be obtained from the dealer.

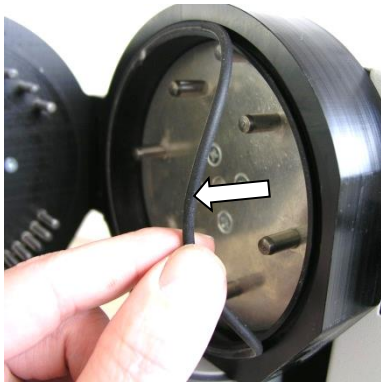

Figure 34: Foam rubber ring milling chamber



Foam rubber ring outlet

Product	Article number
MILOMAT laboratory mill	1520 0700
Mains cable with removable connection (C19/C20 coupler)	2290 0100
Cleaning brush	3190 0027
Turning knob locking spindle	3134 2500
V-belt	3121 2500
Plastic buffer, self-adhesive (foot)	3135 1500
Air filter cutting	3169 5200
Foam rubber ring outlet	3135 5210
Foam rubber ring milling chamber	3135 5220
Outlet, complete	2152 0060
Impact wheel, complete	2152 0102
Condenser for motor	3222 4645
Sample dividing cup with separating sheet and stirring rod (Especially for maize samples)	1520 0550

11 Emergency



⇒ In an emergency, disconnect the MILOMAT from the electrical power supply.

12 Dismantling and disposal



Dismantling is only allowed to be carried out by specialist personnel, refer to the definition in **chapter 2.4**.



⇒ Disconnect the mains plug before you start dismantling.



The MILOMAT must be disposed of in accordance with the applicable local environmental regulations (waste electrical and electronic equipment directive 2012/19/EU).



Special waste

Oil, cleaning agents, contaminated cleaning tools (brush, rags, etc.) must be disposed of according to the local regulations and in accordance with the notes in the manufacturers' safety data sheets.