

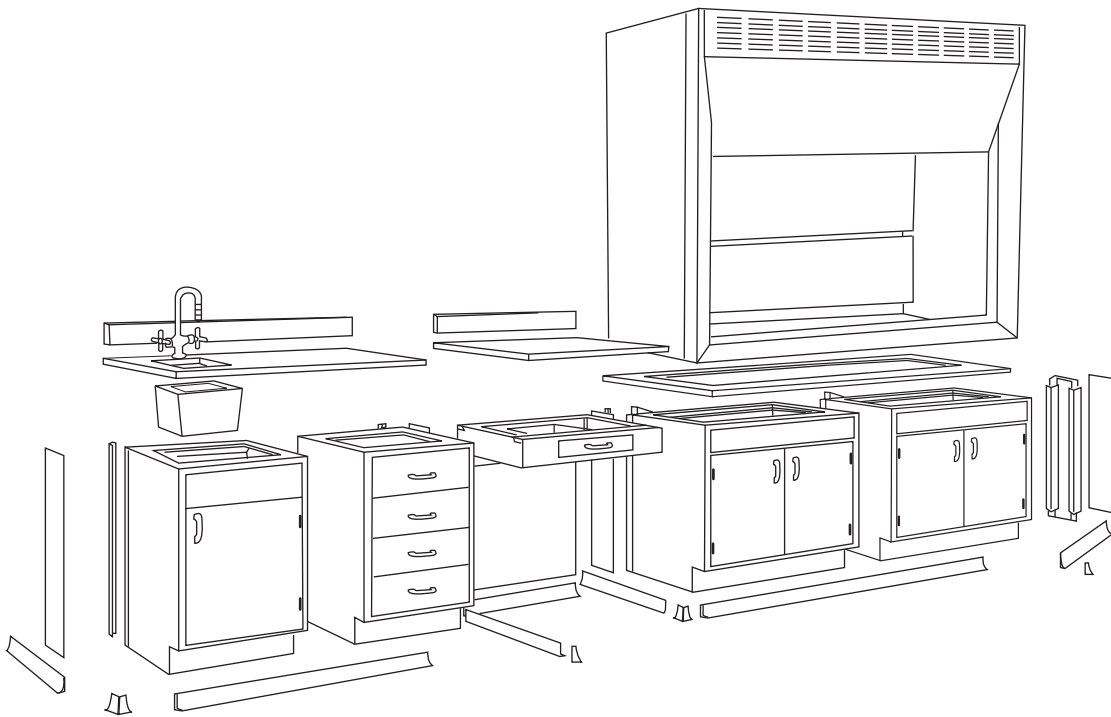

INSTALLATION INSTRUCTIONS



FOR WOOD AND STEEL FURNITURE

IM-1107

P.O. BOX 1842 • STATESVILLE, NORTH CAROLINA 28687-1842
PHONE (704) 873-7202 • FAX (800) 932-3296

TABLE OF CONTENTS

INTRODUCTION.....	page 1
DAMAGES IN SHIPMENT	Page 4
UNPACKING AND LAYOUT OF FURNITURE	page 6
INSTALLATION PROCEDURES AND ASSEMBLING INSTRUCTIONS FOR:	
KEMSTRUTS	page 6
KEMSTRUT TOP SUPPORTS (STEEL FURNITURE).....	page 7
WALL MOUNTED STORAGE CABINETS.....	page 8
BASE CABINETS.....	page 9
COUNTER MOUNTED STORAGE CABINETS.....	page 10
FULL HEIGHT STORAGE CABINETS	page 11
APRONS, APRON TABLE LEGS.....	page 12
SINK PLUGS, TUB SINKS, CUP DRAINS.....	page 14
KEMRESIN TROUGHS.....	page 17
WORK TOPS (KEMRESIN, KEMROCK, WOOD, STAINLESS STEEL)	page 19
REAGENT RACKS (OPEN TYPE-WOOD & STEEL FURN.)	page 23
REAGENT RACKS (FACIA TYPE-WOOD & STEEL FURN.).....	page 23
REAGENT RACKS (STEEL FACIA TYPE-STEEL FURN.).....	page 23
FILLER PANELS & SCRIBE STRIPS (WOOD FURNITURE)	
WALL & CENTER TABLE FILLER PANELS	page 26
TOE SPACE FILLERS	page 26
TOE SPACE FILLERS FOR WALL TABLE END	page 27
WALL SCRIBE STRIPS	page 27
KNEE SPACE PANELS.....	page 28
FILLER PANELS & SCRIBE STRIPS (STEEL FURN.).....	page 29
PEGBOARDS.....	page 41
SELF-ADHESIVE VINYL BASE MOLDING.....	page 42
FINAL ADJUSTMENT OF WOOD AND STEEL FURNITURE.....	page 43
SUGGESTED HARDWARE	page 45

INTRODUCTION

We are pleased that you have chosen Kewaunee quality for your new equipment, and it is our aim to give you the best available products. However, only proper installation will assure your complete satisfaction. Therefore, we have prepared this guide to aid you in the installation of you equipment.

These instructions are for the installation of both wood and steel laboratory furniture assemblies. Many of the instructions are the same for both types, while others are slightly different and are noted accordingly. Please note the instructions contained in this booklet are basic guide-lines and are not meant to cover every situation you may be faced with during the installation process. There will be project specific conditions, which will have to be addressed as they occur. In these instances please feel free to contact us and we will provide assistance as necessary to allow you to complete your installation.

If there are any questions concerning installation or shipping problems, please contact the Installation or Customer Service Department:

Kewaunee Scientific corporation
P.O. Box 1842
Statesville, NC 28687-1842
Telephone (704) 873-7202
FAX (800) 932-3296

Figure 1 shows an exploded view of a typical wood item of laboratory equipment. Figure 2 is the assembled view of the same wood item. Figure 3 shows an exploded view of a typical steel item of laboratory equipment. Figure 4 is the assembled view of the same steel item.

Study these views carefully to fully acquaint yourself with the general scheme of laboratory equipment construction and method of joining the units together to make up a complete item of laboratory equipment.

TYPICAL WOOD WALL AND FUME HOOD ASSEMBLY

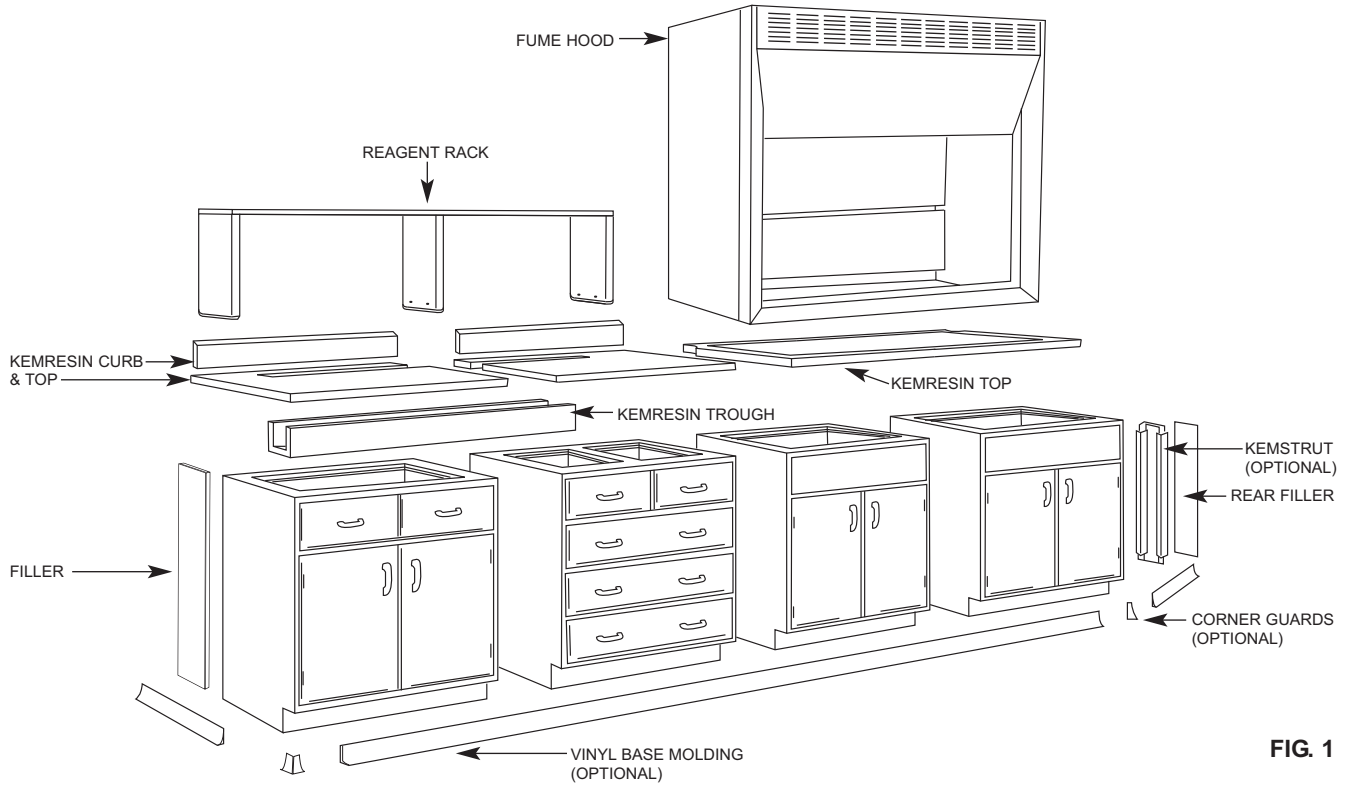

FIG. 1

Exploded view of a typical wood wall and fume hood assembly showing the various parts required to make a complete laboratory furniture assembly. (Figure 1)

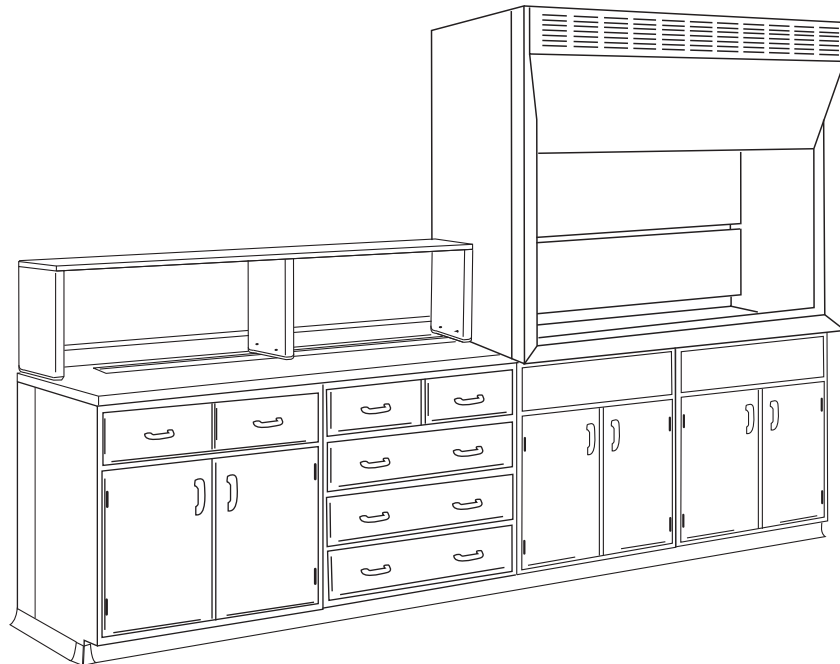

FIG. 2

Completed wood wall and fume hood assembly shown as an exploded view above. (Figure 2)

TYPICAL STEEL WALL AND FUME HOOD ASSEMBLY

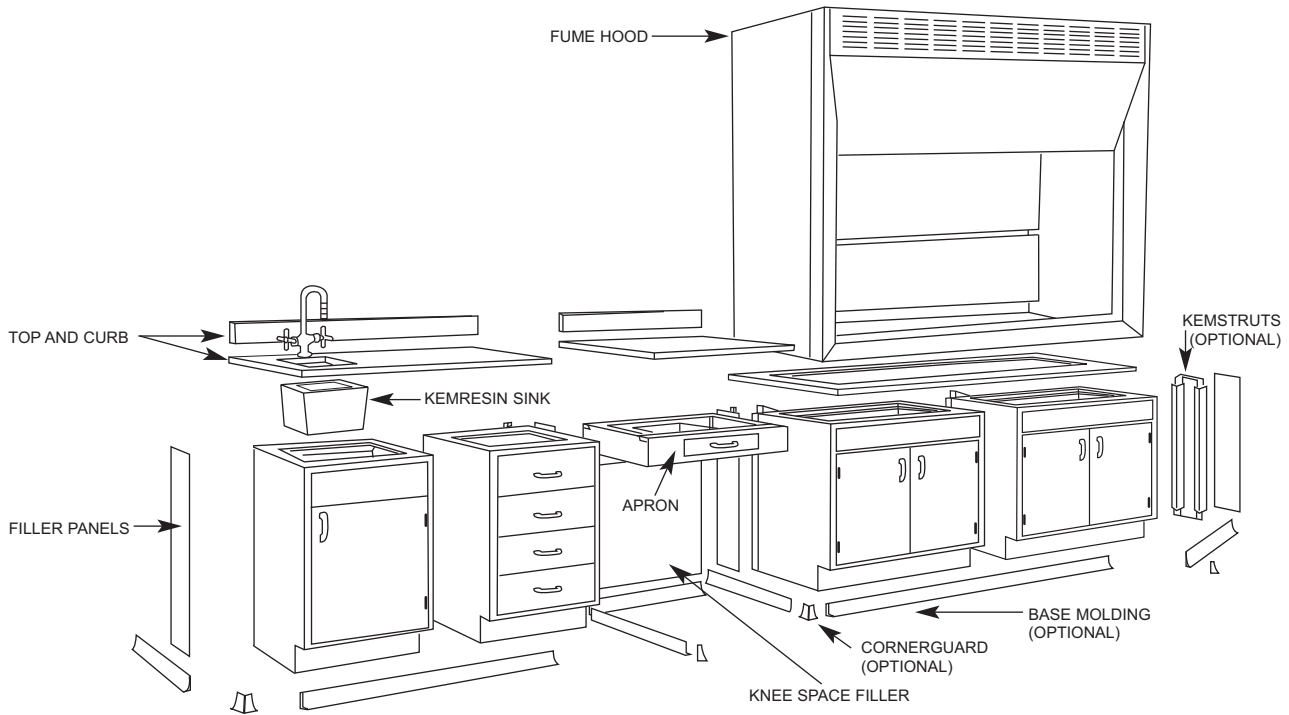

FIG. 3

Exploded view of a typical steel wall and fume hood assembly showing the various parts required to make a complete laboratory furniture assembly. (Figure 3)

Installation instructions for fume hoods are not included in this installation booklet, since specific installation instructions are included with each hood type shipped.

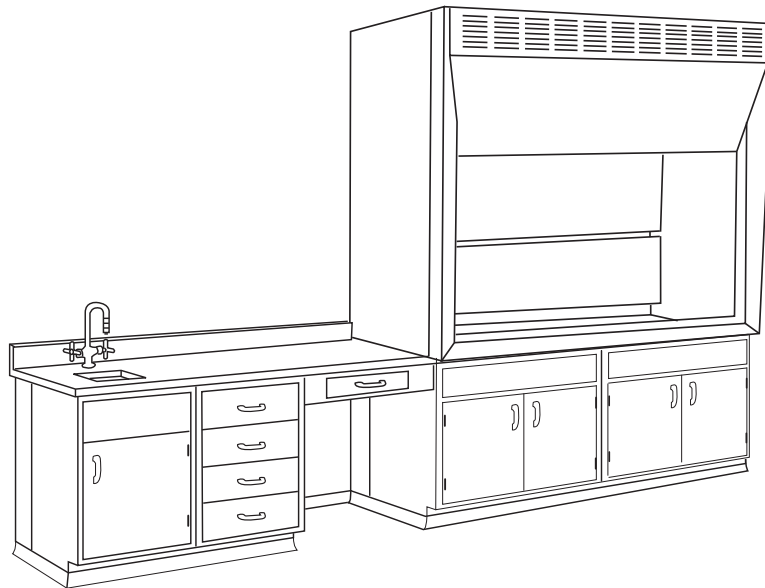

FIG. 4

Completed steel wall and fume hood assembly shown as an exploded view above. (Figure 4)

DAMAGES IN SHIPMENT

IMPORTANT! PLEASE CHECK YOUR FURNITURE IMMEDIATELY UPON ARRIVAL!

Your furniture was accepted by the carrier in good condition and we urge you to inspect each carton for obvious damage to the contents before accepting it. If damage is found, insist that the driver note the damages on the freight bill and sign it. If, after uncrating the furniture, you find concealed damage which was not apparent while the furniture was crated and the driver was on the premises, contact the delivering carrier and request that they send a representative to make an inspection and prepare a concealed damage report. **The inspection must be made and a concealed damage report filed within fifteen (15) days after equipment is delivered.** If the furniture is stored for period of time and then damage is discovered, trucking companies will not make or honor inspection reports.

NET F.O.B. FACTORY OR COLLECT SHIPMENTS - Customer is responsible for filing any claim for damage.

NET F.O.B. DESTINATION OR DELIVERED, INSTALLED JOBS - Shipper is responsible for filing claim; however, proper documents must be forwarded to accomplish this.

PLEASE NOTE: We cannot make “No Charge” replacement on Prepaid Shipment without proper damage documentation, ie. Freight Bills, Concealed Damage Reports, Inspection Reports, etc.

A. If the damage is such that it can be repaired on the job, we recommend that you have the damage repaired and file your claim with the delivering carrier.

B. If the damage cannot be repaired locally, forward the noted freight bill or the concealed damage report to Kewaunee, along with information giving the Item and Section Number of the part that is damaged. Please refer to installation prints for Item and Section Numbers for each piece.

C. Damaged Tops: If damage occurs to tops, handle the same as damage to furniture. A packing list covering the top material shipped to you is included in crate No. 1 of the original shipment from the manufacturer. It will enable you to refer to the crate needed for each item. We realize that different items are sometimes packed in one crate, but like sizes force us to do this to reduce crating expense. Please refer to installation prints for piece marking if breakage or damage occurs.

INSTALLATION

Your furniture is designed to make installation as easy as possible. All necessary scribe strips, fillers and other parts are furnished as ordered to allow you to achieve a complete and finished laboratory installation. A parts list, screw list and hardware packing list are packed in hardware carton No. 1. Be sure to study your prints and packing lists carefully before starting installation of any furniture. This Installation Manual should also be read thoroughly before installation begins.

To aid you in segregating the units required to make up a complete item, each piece of furniture is identified with the Order Number, Part Number, Order Line Item Number and Room and Elevation Number if requested/supplied. Hardware and plumbing fixtures are cartoned and the carton number can be found on the packing list. We recommend that you check the contents of each carton against the packing list and report any discrepancies to Kewaunee promptly. We also recommend that the hardware and plumbing fixtures be locked up until installed. Much time and effort can be saved if the units are segregated as they are unpacked and moved to the approximate location where they are to be installed. The packing lists should be carefully checked during the unpacking process to prevent loose items from being thrown away with the packing material. Any discrepancies between packing slip and material actually received must be reported to Kewaunee within five(5) working days from receipt of shipment.

Each piece of furniture is identified with the Order Number, Part Number, Order Line Item Number and Room and Elevation Number if requested/supplied. On lower cabinets and apron sections, the identification will be on top of the unit or on a tag attached to the cabinet back. On other pieces, a tag will be attached or the Part Number shown on an exposed place on the part. Refer to the installation prints and find the corresponding section or cabinet number and place the cabinets in their approximate final location.

NOTE: Wood table tops are subject to warpage and end checking if stored improperly prior to installation. They should be stored in a dry place on a level surface. Place wood strips between tops, at intervals of not more than four feet along the length of the top and crossway to the grain of the top. Cover tops with a protective covering to minimize damage.

NOTE: Before starting the actual casework installation, check the scribe and filler type you have against the trim section of this booklet, as it is necessary for some types of trim to be installed prior to setting cabinetry.

UNPACKING

To remove the unit from the shipping carton, open the top of the carton and then lay the carton on its back. While holding the carton with one hand, pull the unit from the carton with the other. Be careful not to damage the back of the unit. While the unit is still on its back, remove the shipping cleats from the bottom of the end panels if it is a wood unit. Stand the unit upright.

If units are blanket wrapped, carefully unwrap blanket and place blanket back in trailer. Once unit is in approximate location it is to be installed, carefully remove any tape or strapping material that is holding doors and drawers in place.

LAYOUT

When the units that form a complete item have been placed in the approximate location where they are to be installed, arrange the units according to the installation drawings. Once this has been done, locate the high point in the floor by leveling across the tops of the units. When the high point has been determined, level to the starting point to determine the height the first unit must be set to maintain the level of the highest unit.

KEMSTRUT INSTALLATION

If Kemstrut assemblies are to be used to support plumbing and drain lines, they should be installed at this time. These strut assemblies should be installed tight against the wall.

CAUTION! Be sure to locate Kemstruts as indicated on drawings. Locate the Kemstruts and anchor to the floor and wall, per local code requirements, using fasteners as required to be compatible with floor and wall material. **Due to varying floor and wall conditions, fasteners for attaching Kemstrut assemblies to the floor or wall are not furnished.** Then, have the respective trades install servicelines as required. To clamp a pipe in place, place the pipe clamp on a bolt and start the threads into the clip nut. Then, turning the nut lengthwise with the slot in the channel, insert it in channel. Then turn the nut 90° into position, and tighten the bolt in the clip nut until the serrations grip the return on the channel. (See Figure 4a for illustration of pipe clamps and drainline support in position. See figure 4b for a rear view of completed wall table assembly with base units, work top and piping in place. **Drain line support and pipe clamps are not furnished unless specified.**

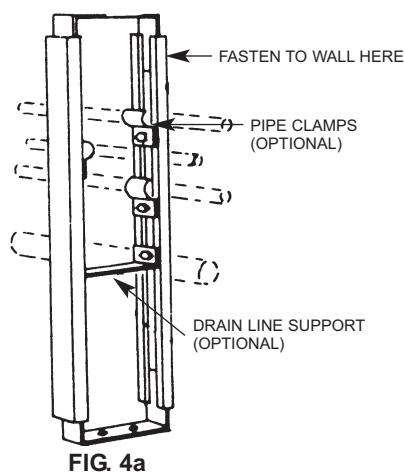

FIG. 4a

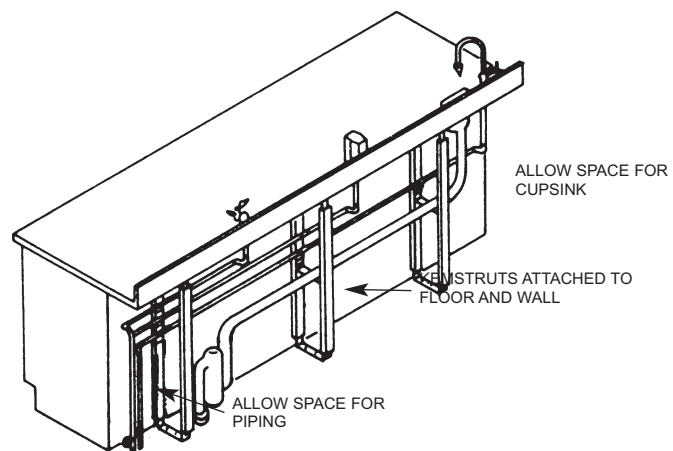

FIG. 4b

INSTALLATION OF KEMSTRUT TOP SUPPORT (STEEL)

Kemstrut Top Supports (No. K-0016-1A or K-0020-1A) are designed to be used in the corner of L-shaped wall assemblies between adjacent cabinet runs to provide support for the work top in the corner. This is used where the walls are of such construction that wood cleats or steel angles cannot be used (or where the owner does not want anything attached to the walls).

Assemble Kemstrut top support as illustrated in Figure 5.

Position and level cabinet units for Run "A". Measure and position cabinets correctly to accommodate the necessary corner filler panel (see Figure 8).

As illustrated in Figure 9, position top support so one arm is flush with top of unit. Drill hole in rear top rail of unit (see Figure 6). Attach arm to unit with 1/4-20 x 3/4" Hex-Head bolt through the F-0169-02 nut (see Figure 7).

Position the F-0169-02 nut and level cabinet units for Run "B" (see Figure 10) and installation drawings for proper "X" dimension. Attach other arm of the top support to the adjacent base unit as illustrated. (see Figure 10).

Level along both legs of the furniture assembly and the top support. Adjustments in height can be made in the vertical leg of the top support if required.

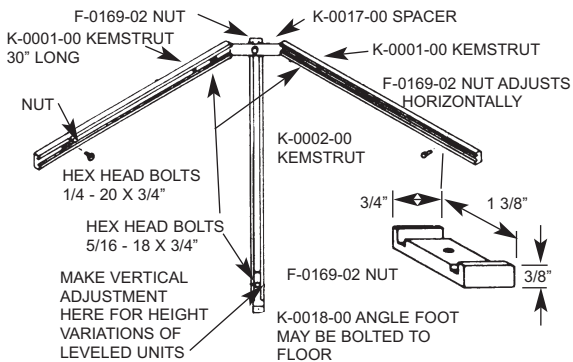

FIG. 5

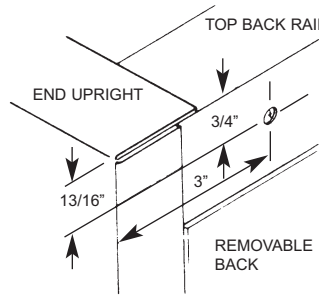

FIG. 6

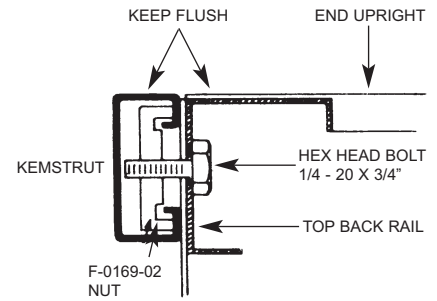

FIG. 7

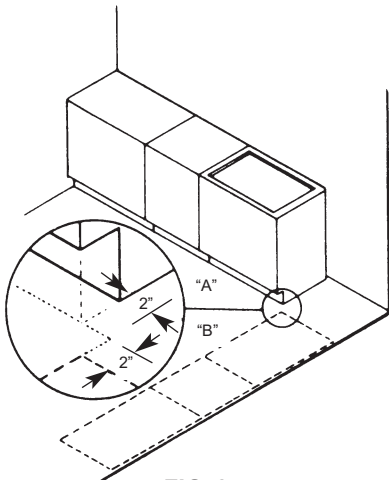

FIG. 8

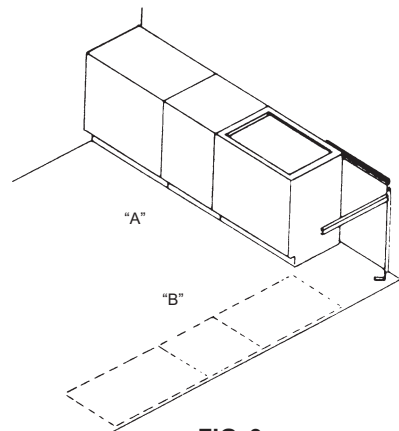

FIG. 9

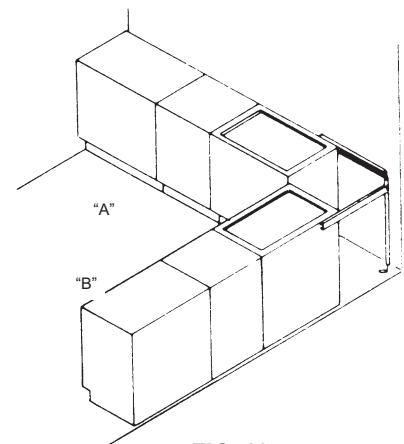

FIG. 10

WALL MOUNTED STORAGE CABINET INSTALLATION

Wall cabinets are hung by first attaching wood cleats to the wall and then securing the cabinets to the cleats with screws.

Determine the exact location of the cabinet and mark the desired location of the top left corner on the wall. Locate the cleats as shown in Figure 11. If more than one cabinet is to be installed in a row, make a chalk line on wall to line up the top of cleats. Make sure chalk line is level.

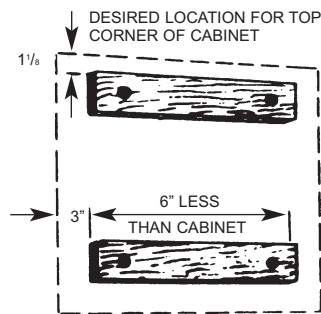

FIG. 11
Mounting Cleats On The Wall

Wood cleats (not supplied) should be 3" to 4" wide and 3/4" thick. Cut them 6" less in length than the length of the cabinet. Mount the cleats as shown with heads of fasteners recessed flush with the face of the fronts of the cleats. Check the face of the cleats for plumb and, if necessary, insert shims between the cleat and the wall to bring to plumb. Wood cleats should be secured to the wall using appropriate fasteners as dictated by wall construction. (Due to varying wall material, fasteners are not furnished with the equipment).

Drill 9/32" hole in the back of the cabinet approximately 4" from each side of the cabinet and on the centerline of each cleat (4 holes). Set the cabinet in place, allowing the top rear rail to rest on the tops of the wood cleats. Fasten it to the wood cleats using #12 x 1-1/4" oval head screws with #12 countersunk washers.

If more than one wall cabinet is to be installed in a row, first install all cleats on the wall in the same manner as described above. The cleat fronts should all lay in a straight line. High spots in the wall should be leveled and low spots shimmed out to bring cleat fronts straight. (Check with straight edge). Improperly aligned cleats will cause misalignment on the face of the cabinets.

Screw the first wall-mounted storage cabinet to the cleats as described above. Next, place the second cabinet into position. Fasten it to the first cabinet making sure the fronts and edges are in a straight line and the units are plumb. Then secure the cabinet to the wall cleats. Continue this process until all cabinets have been installed.

BASE CABINET INSTALLATION

When cabinets are located next to an adjacent wall, refer to the filler installation section before setting the first cabinet. If the first item is an apron, refer to apron installation. In a wall-to-wall configuration, both ends of the assembly must be addressed.

Move the first cabinet into its final location and bring it to the proper level. If the cabinet is steel, level with leveling bolts (Figure 12). If the cabinet is wood, bring to level with shims as shown in Figure 13. Where more than 10 shims are required to bring the cabinet up to level, use a piece of crating lumber as the bottom shim, and make final adjustments by placing shims on top of the crating lumber. If a wood shim is not allowed, cut short lengths of Kemstrut channel and use instead.

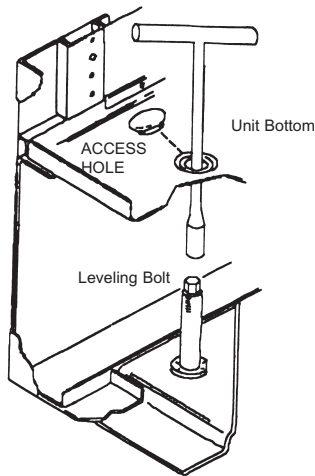

FIG.12
Leveling Bolt for Steel Cabinets

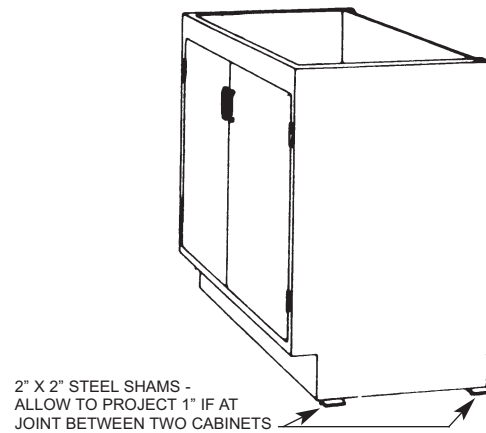

FIG. 13
Placing Shims to Level Wood Cabinets

Set the next cabinet in place and level in the same manner. Fasten the second cabinet to the first, using screws provided.

Repeat the above process until all cabinets for the assembly have been installed. Be sure to check the alignment of the cabinet fronts and tops as you proceed to make sure they are flush and level. (see Figure 14 below).

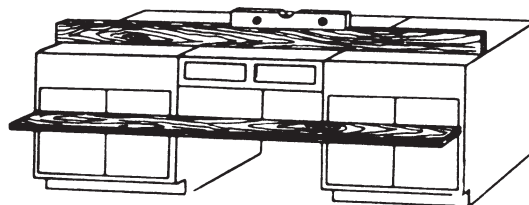

FIG.14
Checking Alignments of Cabinets Fronts and the Leveling of Cabinets

INSTALLING COUNTER MOUNTED STORAGE CABINETS

1. Counter mounted storage cabinets sit on top of a laboratory work top, and are secured to the wall at the top with cleats similar to these used in wall mounted cabinet installation.

2. First position and level the base cabinet(s) and worksurface(s). Determine the exact location of the cabinet(s), and mark the desired location of the top left corner on the wall. Locate wood cleat 2" below and 3" to the right of this mark (see Figure 15).

3. Wood cleat length should be 6" less than case length; width should be 3" to 4" and thickness not less than 3/4". The cleats should be secured to the wall using fasteners as appropriate for the existing wall construction. Holes for the fasteners should be countersunk or counterbored to make heads flush with face of cleat. (Due to various wall construction, fastening devices are not included.) Wood cleats should be level and plumb. High spots in the walls should be leveled and low spots shimmed out to make the cleats straight (check with straight edge and level vertically and horizontally).

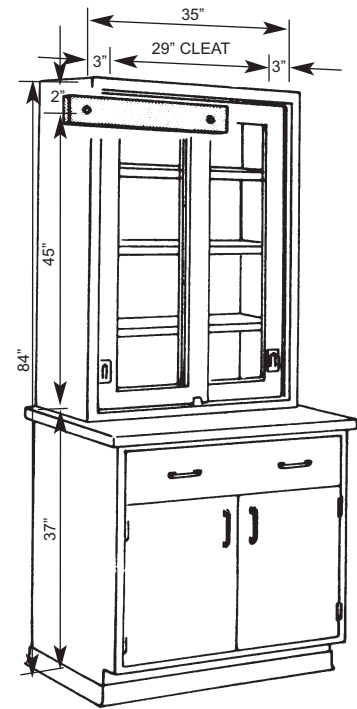

FIG. 15

4. If more cabinets are to be installed in a row, make a chalk line on wall to line up tops of wood cleats. Then, install all cleats on the wall in the same manner as described above.

5. Remove sliding doors from cabinet(s). Drill enough 9/32" holes in back of cabinets to provide for securing to wood cleats at approximately 12" intervals along case length, locating the holes from the wood cleat positions.

6. Set the first cabinet in position on top of the laboratory work top and fasten it to the wood cleat using #12 x 1-1/4" oval head wood screws and #12 countersunk washer. Then, place the second cabinet in position and fasten it to the first cabinet making sure the fronts and edges of the cabinets are in a straight line. Then, screw the second cabinet to the wall cleat. Continue to proceed in this manner until all cabinets have been installed.

7. Install adjustable shelves in cabinets. Three adjustable shelves along with 12 shelf clips are provided. Normally, shelves are installed to provide four approximately equal height compartments, but can be spaced as desired.

8. Clean glass on glazed doors.

9. Replace sliding doors in cabinets.

INSTALLING FULL HEIGHT STORAGE CABINETS

1. Full height storage cabinets should be leveled at the floor line and secured to the wall at the top. Precise leveling is necessary to assure cabinet is plumb and functions properly.
2. Determine the exact location of cabinet and mark the desired location of the top left corner of the cabinet on the wall. Locate wood cleats 3" below and 2" to the right of this mark (see Figure 16).

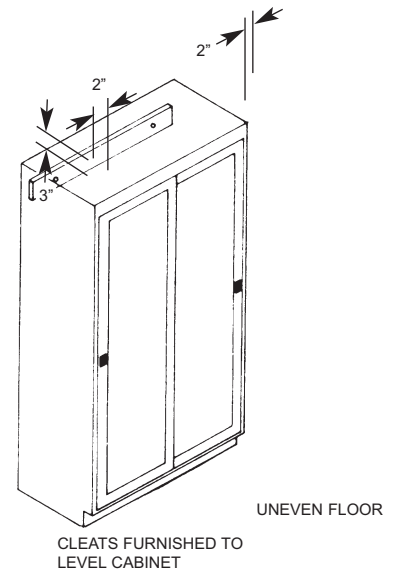
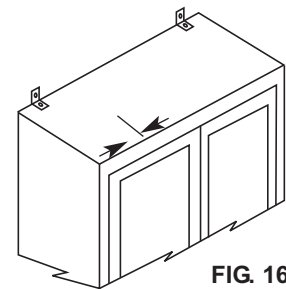

FIG. 16

3. Wood mounting cleat length should be 6" less than cabinet length, width should be 3" to 4" and thickness not less than 3/4". One cleat at the top of a cabinet is generally sufficient to hold it in position. Wood cleats should be secured to the wall using fasteners as required for wall material. (Due to varying wall construction, fastening devices are not included.) Wood cleats should be level and plumb. High spots in the wall should be leveled and low spots shimmed out to make the cleats straight. Check with straight edge and level vertical and horizontally. NOTE: Two small angles can be substituted for wood cleats. Locate the angles on top of the unit approximately 2" in from each side (see Figure 16a). Securely fasten angles to both the wall and the top of the cabinet.



4. If more than one full height storage cabinet is to be installed in a row, make a chalk line on wall to line up top of wood cleats. Then install all cleats on the wall in the same manner as described above.
5. If cabinet is sliding door type, remove doors. Drill a 9/32" hole in back of the cabinet(s) 4" from each side and on the center line of the wood cleat (2 holes). Prior to securing the cabinets to the wall, they should be leveled. Start with cabinet located over the highest point of the floor. To plumb, place level on the top of the cabinet end to determine which corner is highest, then shim under the other corners (see Figure 16). Where two cabinets join, let the shims project 1" beyond the sides of the cabinet. Now, place the second cabinet on the projecting shims and level this cabinet by placing shims at the other corners as required. This should be repeated for as many storage cabinets as there are in a row.
6. Fasten the first cabinet to the wood cleat with screws. Then place the second cabinet in position and fasten it to the first cabinet, making sure the cabinets are level and plumb, and the fronts and edges are aligned. Then secure the second cabinet to the wall cleat. Continue to proceed in this manner until all cabinets have been installed.

7 Clean glass in glazed doors.

8 Replace sliding doors in cabinet.

APRON INSTALLATION

Where an apron section is suspended between two cabinets or between wall and cabinet, fasten the apron to the cabinet. Be sure apron is set back 1/8" from the face of the unit for steel and 1/4" for wood. When an apron is to be fastened to the wall, fasten as shown in Figure 17.

Be sure top of apron is flush and level with adjacent cabinet.

If the apron is supported by a cabinet on one end and legs on the other, install the legs before fastening the apron to the cabinet.

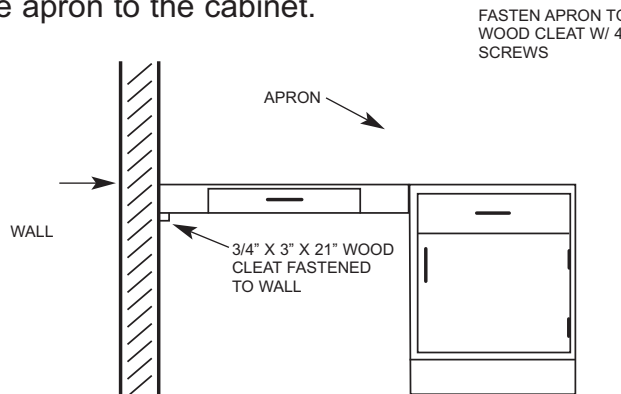

FIG. 17
Apron Installed Between Wall and Cabinet

LEG ASSEMBLY INSTALLATION (WOOD)

Apron legs are shipped knocked down to conserve shipping space and are assembled as shown in Figure 18.

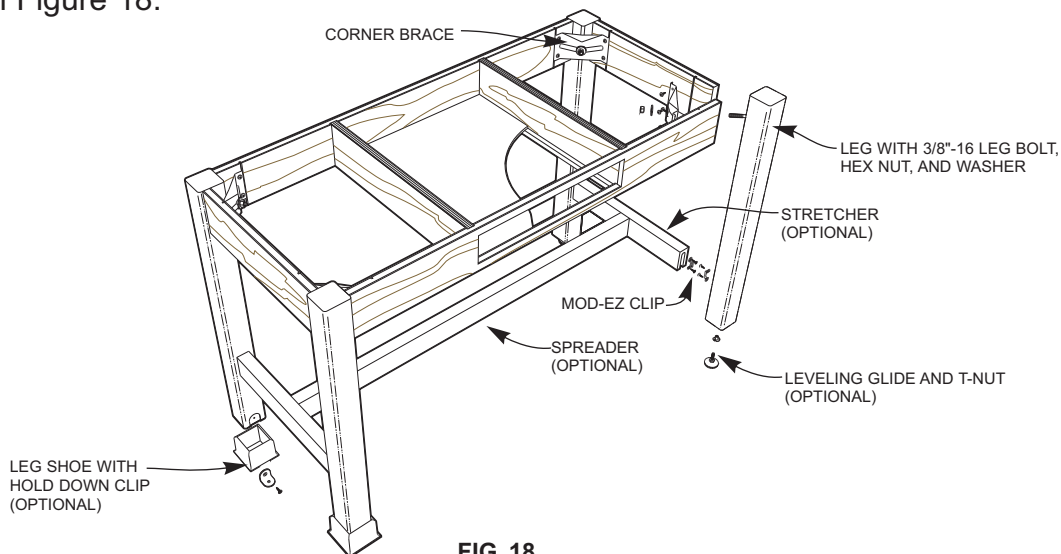

FIG. 18
Leg Assembly Installation (Wood)

Lay the apron section bottom side up on a pad or other suitable protective material to protect the top finish. Set the leg in position with the projecting leg bolts through the holes in the corner brace. Install the washer and nut and tighten securely. Repeat this step until all legs for a given apron section have been installed.

LEG ASSEMBLY INSTALLATION (continued)

Where stretchers are used between legs, screw male half of Mod-ez clip to the leg using the the screws provided and the pre-drill holes. Place stretcher in position and snap the two halves of the Mod-ez clips together. (Female half of Mod-ez clip is installed on strecher at factory.)

Repeat process with spreaders when spreaders are provided.

When legs have been installed, place vinyl leg shoes over the bottom of the leg, if provided, and turn apron right side up. Level with the leveling bolt or shims and fasten to floor with leg holddowns if provided.

LEG ASSEMBLY INSTALLATION (STEEL)

1. Slide leg shoes over bottom of legs. (Omit step if leg shoes are not provided.)
2. Slide bolt plates into top of legs until bolt can be inserted through bolt hole.
3. Align leg assembly with apron assembly and insert leg bolts into holes in apron.
4. Place washer plates over ends of leg bolts from inside apron.
5. Secure bolt plates, leg assembly, apron assembly, and washer plates with 3/8"-16 Nylok hex nuts. Tighten nuts securely.
6. Attach second leg assembly to other end of apron assembly if required.
7. Adjust leveling bolts as needed to level assembly and slide leg shoes to bottom of legs.

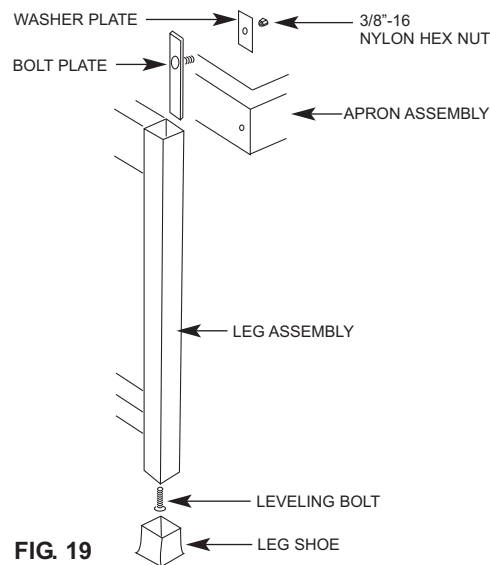

FIG. 19

INSTALLATION OF OPTIONAL SPREADER

1. Loosen Nylok hex nuts that secure legs to apron.
2. Screw 1/4"-20 x 3/8" round head bolts into pre-tapped holes in leg assembly (2 per assembly). Screw all the way in and then back off two turns.
3. Slide spreader over bolt heads and seat. (Note: Top of spreader should be even with top of stretchers on leg assembly.)
4. Tighten all four spreader bolts.
5. Re-tighten Nylok hex nuts that secure legs to apron.

INSTALLATION OF SINK OUTLETS, TUB SINKS AND CUP DRAINS SINK OUTLETS

1. Clean the rabbeted cutout in the sink bottom with a clean damp cloth. Clean the mating surfaces of the drain outlet and any gaskets. Do not soak, merely wipe clean to remove dirt and oils.
2. Apply concentric rings of 1/2" wide sealing putty to the bottom face of the sink outlet. These rings should be tight together, but not necessarily overlapping. (It is easier to apply sealing putty to the outlet, but it may also be applied to the rabbeted cutout. The result will be the same.) Two concentric rings are required for 1-1/2" drain outlet (16" to 18" of sealing putty). If a gasket is provided, for outlets such as Teflon or plastic, place the gasket in place on the outlet before applying the sealing putty (see Figure 20).
3. Position the outlet in rabbeted cutout inside the sink and secure lock nut under the sink to compress sealant. Re-tighten lock nut after a few moments to ensure a good seal.
4. Caulk the space between the outlet and the edge of the rabbet on the sink bottom with epoxy cement or black caulk (see Figure 21). Cove the joint with a finger to give a finished appearance. Clean up the sink bottom with warm, clean water and a clean cloth.

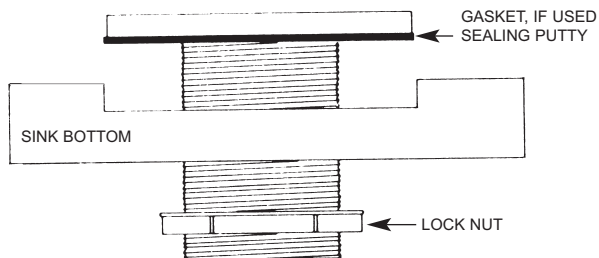

FIG. 20

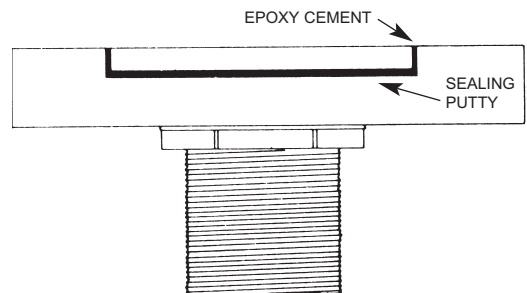

FIG. 21

TUB SINKS

1. Tub sinks are suspended inside the sink cabinet by sink supports prior to top installation. First install the sink support components as shown in Figures 22 and 23. To install, set the tub sink in place on the supports and adjust the sink supports so that the top edge of the sink is approximately 1/2" below the top of the sink cabinet.
2. Clean top edge of sink with a clean damp cloth. Then apply 2 layers of sealing putty around the top edge of the sink. If putty does not adhere to the sink, repeat the cleaning step and then apply the sealing putty. (see Figure 22). You may use acid resistant silicone or epoxy cement in place of the sealing putty if contract documents permit its use.

INSTALLATION OF TUB SINKS (Continued)

3. Install sink top, then center tub sink under cutout.

4. Raise the sink to underside of sink top just enough for the sealing putty, silicone, or epoxy cement to make a continuous seal between top of sink and underside of sink top. Avoid over-tightening sink adjustment bolts or counter top can be lifted off of the cabinets.

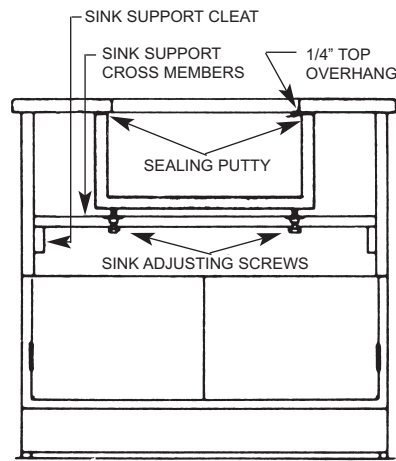

INSTALLATION OF SINKS

FIG. 22
WOOD

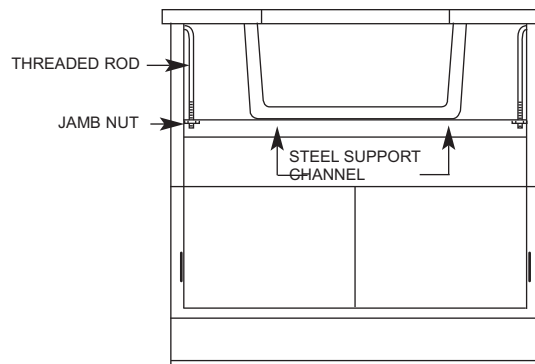

FIG. 23
STEEL

CUP DRAINS

Clean cup drain cutout and edges of cup sink with a clean damp cloth. Then install by laying two strips of sealing putty in the recess under the cup drain flange and one strip of sealing putty around perimeter of flange and edge of work top to seal against water leakage. (See Figure 24). If putty does not adhere to cup drain repeat the cleaning process. Acid resistant silicone, or epoxy cement may be used in place of the sealing putty if contract documents permit its use.

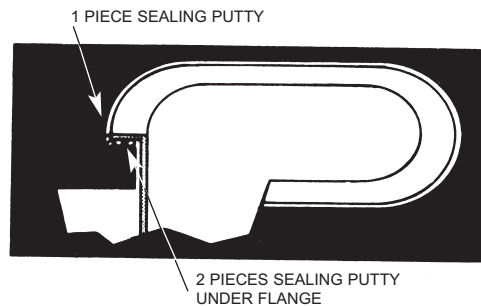

FIG. 24

INSTALLING TROUGHS

Adjust supporting “Kemstruts” (Figure 25) to a height to allow trough to be 3/8” below the top of the cabinets. Set trough on Kemstruts to approximate final location. Clean bottom of counter top and top of trough with alcohol and a clean cloth. Apply sealing putty to top edge of trough. You are now ready to set tops. When tops are in place, shim trough tight against underside of top to ensure proper seal. Acid resistant silicone may be used in place of sealing putty if contract documents permit its use.

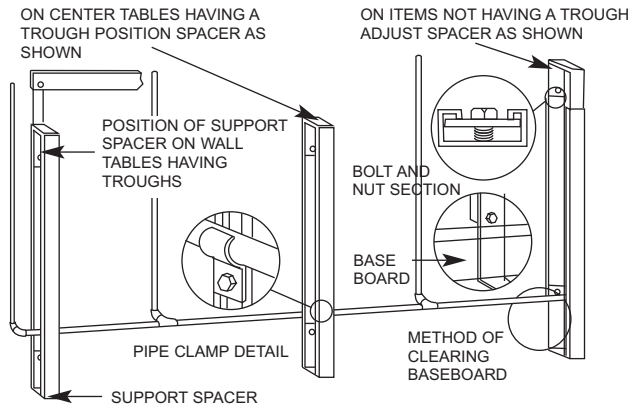

FIG. 25
ILLUSTRATION OF KEMSTRUT SUPPORT RACK
BEFORE INSTALLATION OF TROUGH

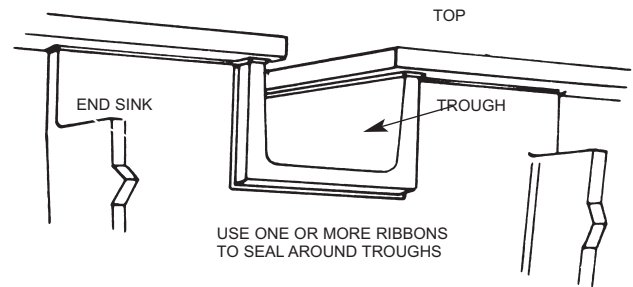

FIG. 26
ILLUSTRATION OF TROUGH AFTER INSTALLATION

INSTRUCTIONS FOR FIELD ASSEMBLY OF KEMRESIN TROUGHS

1. Assemble trough sections per drawing. Place sections bottom side up on a clean level surface and shim where necessary to assure a level trough and a square joint. (Stock trough sections carry numbers TR-1, TR-2, TR-3, TR-4 and TR-5.) (Special section lengths will carry a “J” part number.)

Joint clips and Epoxy Field Kit Cement are included, along with screws, bolts, etc. necessary for trough assembly. Locate these items before proceeding with the assembly.

2. Where trough sections join, ends have been sanded for better cement adhesion. If this operation was overlooked, please roughen ends with #80 or #100 grit emory cloth.

3. Clean ends of trough sections with a clean damp cloth.

4. When trough sections are ready to be joined, mix Epoxy Cement in accordance with directions on tubes or cans. Mix cement on a clean, smooth flat surface and blend for several minutes with a spatula. (Mix only enough for one joint at a time.) (The upturned bottom of the trough makes a good mixing surface.) Temperature should be above 65 degrees to allow cement to adhere and set properly.

5. Spread the thoroughly mixed cement to both ends of the surface to be joined and force sections of trough together.

INSTRUCTIONS FOR FIELD ASSEMBLY OF KEMRESIN TROUGHS (Continued)

6. Place formed steel trough clips into grooves adjacent to the joint and tap down lightly to apply pressure to the joint. Alternate tapping of the clips from one side of the trough to the other to bring even pressure on the joint. When a tight joint has been secured, clean excess adhesive from trough bottom with warm water and clean cloth. Complete other joints following the same procedure.
7. Turn the trough over to its normal useable position, using one man for each trough section. Elevate trough on blocking to avoid cement adhering to a flat surface. **Clean cement from inside of trough joint area with water or solvent. Clean up must be done while cement is still soft. The cleaning process should be completed within 15 to 30 minutes of application.**
8. Examine joint or joints to make sure the sides are aligned. If not, clamp top edge of the trough with a "C" clamp until cement sets. Recheck to assure all excess cement has been cleaned from inside surfaces.
9. We recommend that cement be placed in grooves adjacent to side clips, thereby permanently cementing them in place.
10. The completed trough should remain undisturbed overnight at normal room temperature 65 degrees or above. If temperature is below 65 degrees, some method of increasing temperature is necessary to promote a strong joint. **Epoxy cements will not cure properly at temperatures below 55 degrees F.**
11. Cement will attain about one-half strength overnight at normal room temperature. Placing the assembled trough on the permanent supports should be done carefully, using one man per section when handling.

If you have specific problems or questions during the above operation, please contact our factory.

INSTALLATION OF WORK TOPS

Before installing work tops, make sure base cabinets, aprons, wall supports, and Kemstruts are level. Lay all top sections in place, checking carefully with the installation drawings to make sure the proper sections are used. Check all fixture holes and sink cutouts for proper size and location. Make sure each piece is evenly supported. If the base units have been properly leveled, the top sections will lie smoothly, with top surfaces flush. If you have a slight variation in top thickness from one section to another, make sure the variation is at the bottom of top. Top surfaces should be level.

KEMERESIN TOPS

Before placing top sections on the support structure, scuff sand edge to be cemented and wipe each edge with a clean cloth dampened in lacquer thinner or equal solvent. Start from one end and shift top sections to provide a 3" space between first and second section.

CAUTION: These solvents are extremely volatile and must not be used near heat or flame. You must also be in a well ventilated area when using these solvents.

You are now ready to mix the two part Epoxy cement. Follow directions on cans carefully and only mix as much as can be used in 15 or 20 minutes. The two components must be thoroughly mixed for proper adhesion. The mixing process usually takes 5 minutes or longer depending on room temperature. **Adding extra hardener will not speed up the curing process. Do not attempt to cement tops together if a minimum room temperature of 55oF is not being maintained.**

Cover the joint edge of the top sections with enough cement to make a reasonable width joint seam. Align sections and slide working sections back and forth, front to back until proper joint is attained. This will force out surplus cement. The same result can be obtained by the use of pipe clamps if walls do not interfere. If clamps are used, leave them in place overnight to ensure proper cement set-up. (Place a piece of cardboard under joint at front to keep cement off of casework, remove cardboard after cement has set up.)

After the joint is made, clean it by scraping excess cement from surface. (Use a putty knife without burrs to avoid scratching surface). Wipe joint and adjacent areas with a clean cloth slightly dampened with water. Do not let cement harden before cleaning or it will be impossible to remove. Continue with other joints using procedures described above.

If necessary, a small "C" clamp can be used at the front overhang at a joint to align adjacent top sections vertically. Do not put cement in the joint at that point. Cement should be added later after the rest of the joint has set and clamp is removed.

KEMERESIN TOPS (continued)

Use a small amount of Epoxy cement at the four corners of the base unit to secure tops. Use extreme care not to get cement on the finished surface.

After the entire top is completed, clean with detergent and water, wipe dry and apply a coat of any furniture polish. Apply polish sparingly and wipe with a dry cloth to achieve the desired luster.

The installer is to carefully clean all foreign debris and dust and carefully polish countertops and work surfaces. The installer is to provide protection to the countertops and work surfaces after installation and cleaning by carefully covering the entire countertop surface with heavy gauge clean construction paper, clean corrugated cardboard or other suitable materials and taping the protective material to the countertop, along the entire countertop perimeter, with painters' masking tape. Warning signs should then be placed on the top with the protective materials.

NOTE: Do not store tops on side or bottom. Please follow recommended storage instructions on outside of cartons.

NOTE: After tops have been installed for approximately 24 hours the epoxy cement in joints will shrink. Each joint should be re-grouted to give the top a smooth surface across each joint.

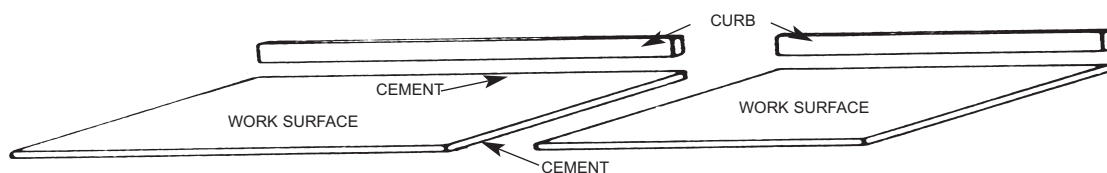

FIG.27

WOOD TOPS

Joints are made in wood and plastic laminate tops as shown in Figure 29. Lay the tops on the unit with the ends about 9" apart and cover the end surface of one top with Ribbon Flat Mastic or silicone sealer-end to end so the routs for the joint fastener are accessible. Install one OP-0310-00 fastener (Figure 30) in each rout pair in each section of top. Using a 3/8" wrench, tighten each fastener until you have hairline joints in tops. Place tops in their permanent location. Secure to understructure as required. (see Figure 31)

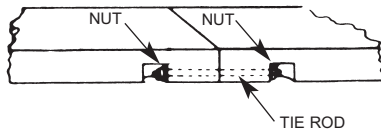

FIG. 29
METHOD OF JOINTING WOOD OR
PLASTIC LAMINATE TOPS

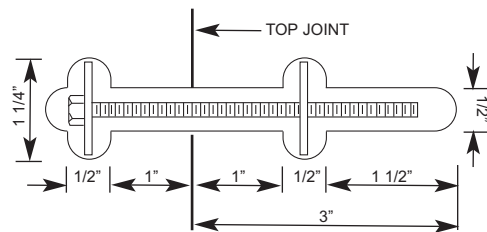

FIG. 30
CROSS SECTION THROUGH TOP
ILLUSTRATING FASTENER POSITION

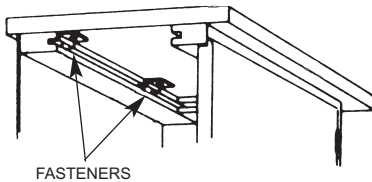

FIG. 31
METHOD OF ANCHORING WOOD, PLASTIC
LAMINATE, OR STAINLESS STEEL TOPS

STAINLESS STEEL TOPS

Curbing along back and sides are made as an integral part of the top.

Whenever it becomes necessary to make the top in two or more sections due to length of room or room conditions, the tops are fastened together by a mechanical joint concealed below the working surface of the adjoining top. The 1" x 1" angles, which are welded to the edges of the top, are bolted securely with 1/4" - 20 bolts. This allows the tops to be assembled as one complete top.

To install tops, place blocks on top of base units (units should be located in their permanent positions). Lay each section of top on the blocks. With adjoining tops in position, bolt together at the mechanical joint. After all mechanical joints are securely fastened, blocks are removed and top is lowered into its permanent position.

Tops are now fastened to units with screws and hold down clips in Figure 31. Use #10 x 1" round head wood screws for this purpose.

INSTALLATION OF STEEL REAGENT RACKS

Reagent racks are shipped knocked down and are to be assembled during the installation process. A partial exploded view of a typical reagent rack is shown in Figure 32. This view shows all of the parts in their relative positions. Figure 32 also indicates the proper screws to use for rack assembly. Uprights and fascia panels (if applicable) should be carefully positioned and fastened to the worksurface as shown in figures 32a and 32b. Fascia panels are attached with #6 1/4" binding head screws. If possible, it is more convenient to have pipes and conduit installed for services by the appropriate trades before attaching the reagent shelf. ing head screws (See Figures 42 and 43).

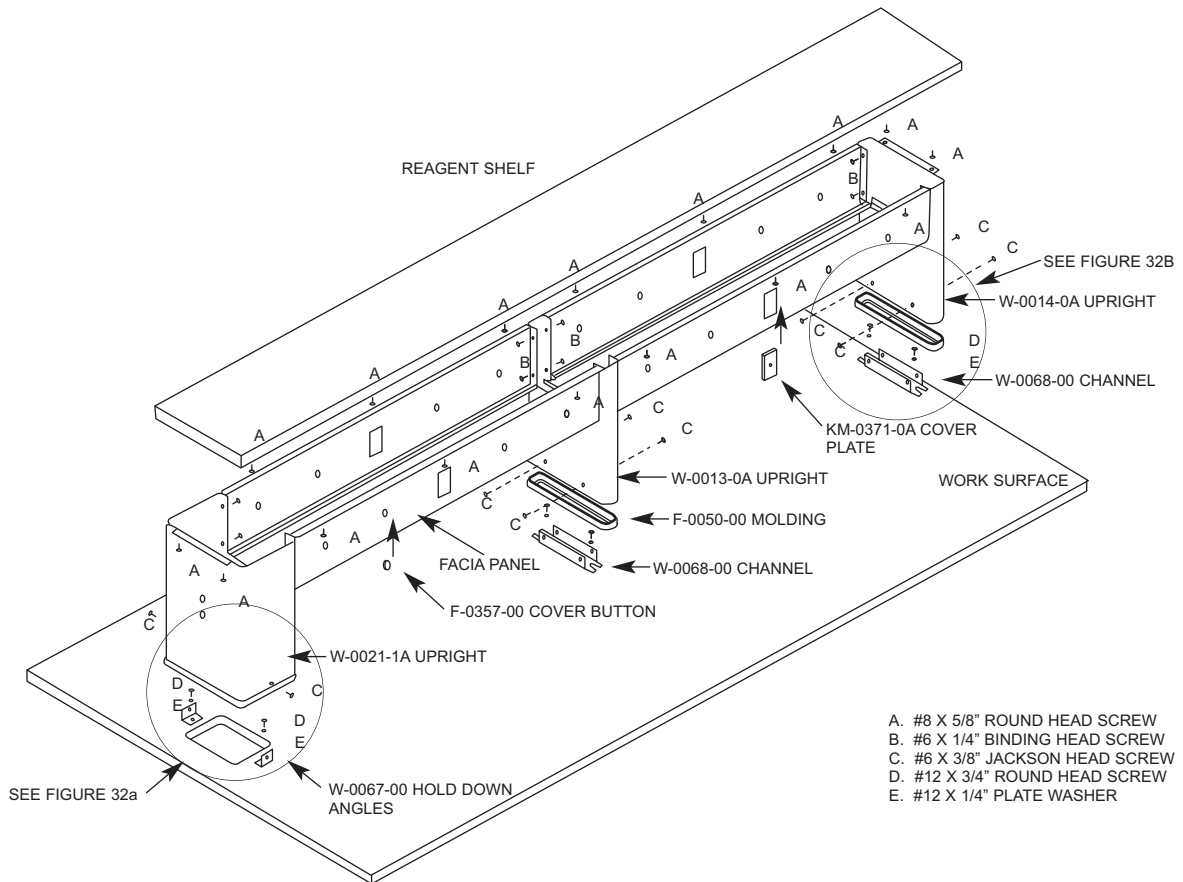

FIG. 32

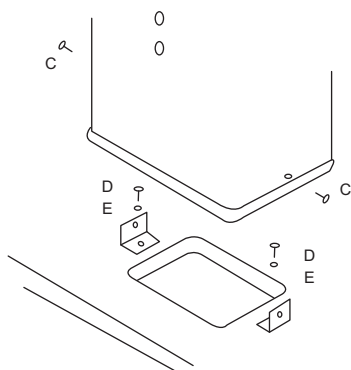

FIG. 32a

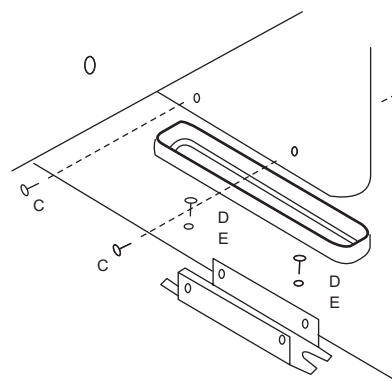

FIG. 32b

INSTALLATION OF STEEL REAGENT RACKS (Continued)

1. Install center table (or wall table) base units and tops as previously described.
2. Mount W-0067-00 hold down angles and W-0068-00 channels on tabletop. For Kemrock or Kemresin tops, epoxy cement should be used for mounting these angles and channels. If tops are wood, holes will have to be drilled in the top for mounting (see Figures 33 and 34 for hole locations). Drill 3/4" deep holes with a No. 17 drill bit. Attach angles and channels to table top with 1/4" plate washers and #12 x 3/4" round head screws.
3. Put rubber moldings in position on underside of reagent rack uprights, and set uprights in position over the hold down angles and channels on the tabletop.
4. Figures 33 and 34 show two configurations of wall table reagent racks. Figure 33 illustrates uprights with service cutouts for pipes and conduit. Figure 34 illustrates intermediate adjustable shelving. Be certain that uprights are located correctly to accommodate the length of the adjustable shelves.
5. Locate complete reagent rack in exact position desired and fasten reagent rack upright to the hold down angles and channels previously installed. Holes are provided in the uprights for this purpose. Use a No. 33 drill bit to drill matching holes in the hold down angles and channels. Fasten in position with #6 x 3/8" Jackson head screws.
6. Mount all plumbing and/or electrical fixtures and make final piping and electrical conduit connections. Cover all unused holes with plug buttons and/or electrical cover plates. (Holes on rear facia panels of wall table reagent racks need not be covered.) In most cases, fixture installation, piping, and wiring are to be performed by other trades concurrently with casework installation.
7. Attach ledge to top of reagent rack. Set ledge in exact position and drill 3/4" deep pilot holes into underside of ledge through punched holes in top flanges of facia panels and reagent rack uprights. Use a #29 drill bit for this function. If ledge comes in two or more section, cement sections together before attaching it to the reagent rack.

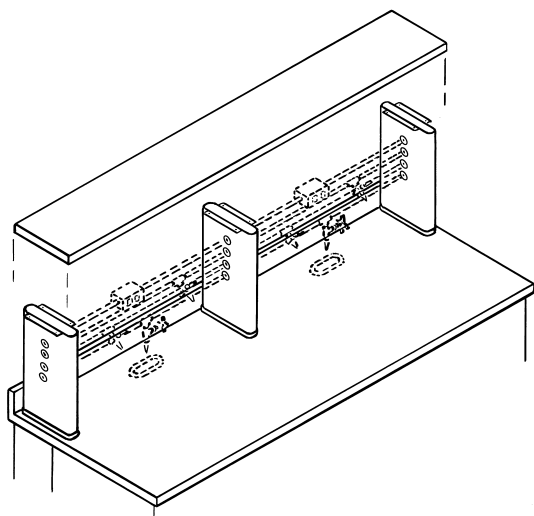

FIG. 33
REAGENT RACK UPRIGHTS WITH SERVICE CUTOUTS

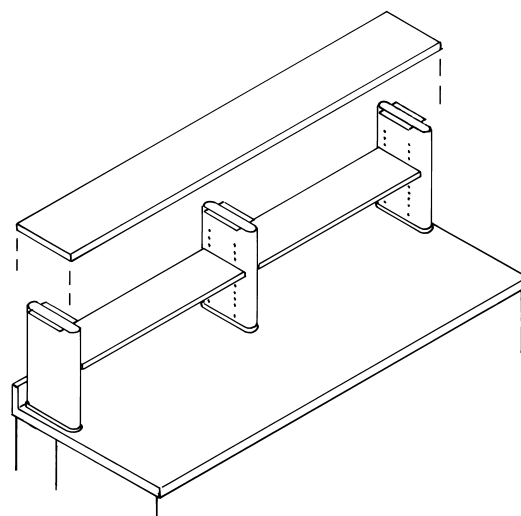

FIG. 34
REAGENT RACK WITH ADJUSTABLE SHELVES

INSTALLATION OF STEEL REAGENT RACKS (Continued)

In some instances, the standard reagent rack facia panels may have to be modified to provide the desired reagent rack length. To do this, the ends of the reagent rack facia panels should be cut off as shown by the dotted lines in the upper portion of Figure 35. Then, the cut edges should be trimmed to form angle clips as shown in Steps A, B, C and D of Figure 36.

Attach angle clips to reagent rack uprights (as shown in lower portion of Figure 36) with #6 - 3/8" Jackson head screws. Drill two clearance holes in ends of reagent rack facia panels. Set facia panel in position so that it is tight against the uprights and top flange is level with the top of the rack upright. Then, use a No. 32 drill to put holes in angle clips through the clearance holes in ends of facia panels. Attach facia panels with #6 - 3/8" Jackson head screws.

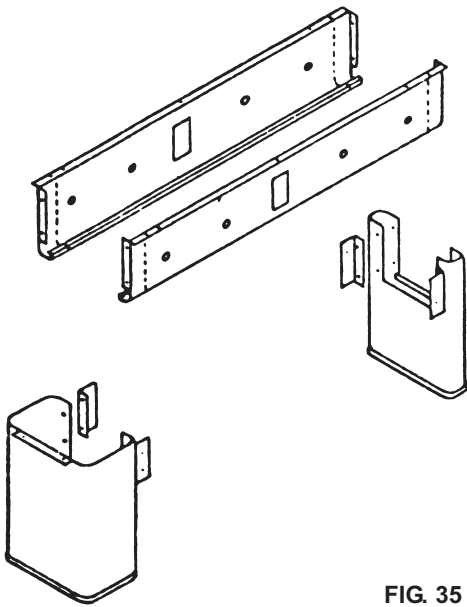

FIG. 35

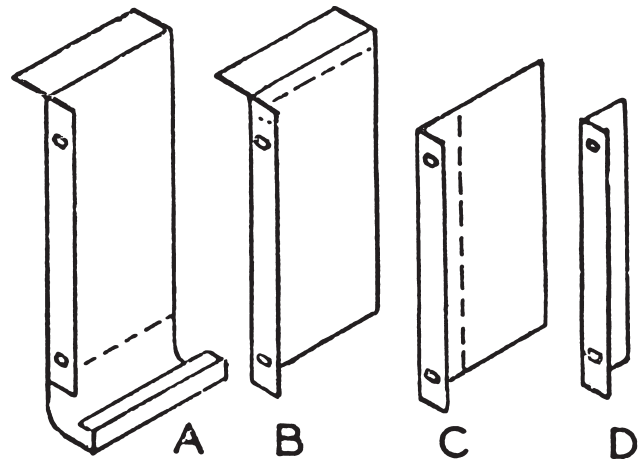

FIG. 36

INSTALLATION OF FILLER PANELS AND SCRIBE STRIPS FOR WOOD

When all plumbing and/or wiring has been completed, install the filler panels and scribe strips. In general, filler panels and scribe strips are used to fill in any openings left between cabinet units and the wall, or open spaces between cabinets. Careful installation of these items will improve the appearance of the furniture, and aid in keeping the laboratory clean.

WALL & CENTER TABLE FLUSH FILLER PANELS

Plumbing space wall and center table filler panels are normally 7" to 8" wide, and are furnished with two 3/4" x 3/4" mounting cleats. They are installed flush as illustrated in Figure 37. For a wall table filler, attach one cleat to the wall, and the other cleat to the rear of the base unit with #9 1-1/4" flat head wood screw. (Use a No. 5/32" drill). The filler panel is attached to the cleats with #6 round head wood screws. For a center table filler attach the two cleats to the rear of the base units with a #9 - 1 1/4" flat head wood screws. The filler panel is attached to the cleats with #6 - 3/4" round head wood screws. **Be sure to attach the rear cleat to the wall before cases are set.**

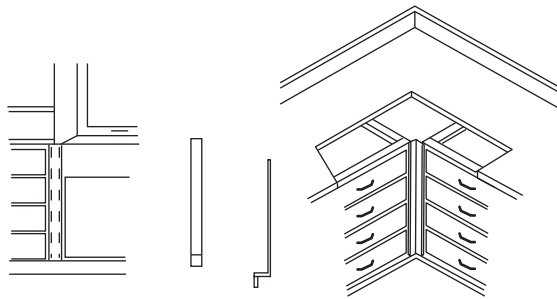

FIG. 37

INTERMEDIATE OVERLAPPING FILLER PANELS

Overlapping intermediate filler panels are installed overlapping the front edges of adjacent units (Figure 38a and 39). Install by placing the toe space filler panel in position and drill the edges of the units with a No. 1/8" bit for #6 round head wood screw.

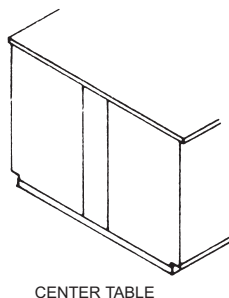

FIG. 38a

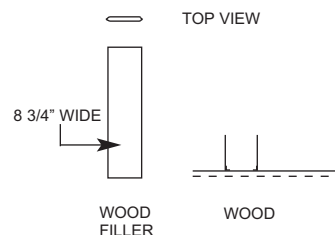

FIG. 39

OVERLAPPING WALL TABLE END FILLER

Overlapping end filler panels are installed overlapping the edge of a unit on one side and butts against the wall on the other side. Wall table end filler panels (Figure 38b & 40) are provided with one 3/4" cleat to attach to the wall. The filler panel is then put into position and the edges of the unit and the cleat are drilled with a 1/8" drill for #6 flat head wood screws.

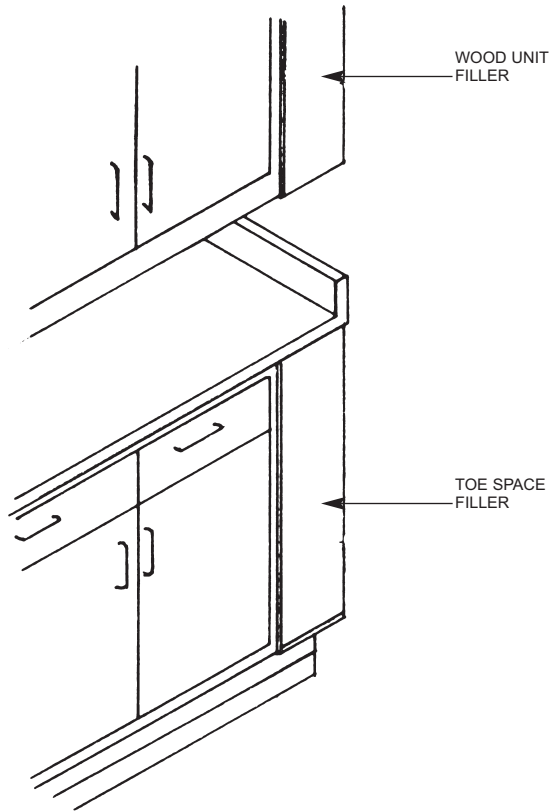

FIG. 40
TOE SPACE WALL & TABLE FILLER

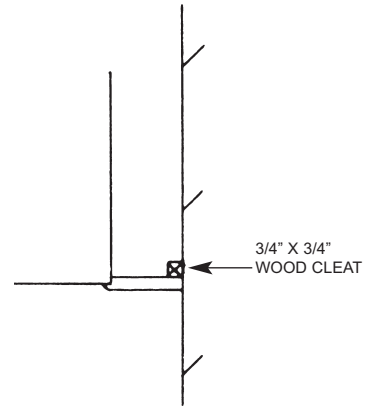
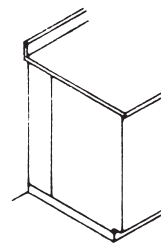

FIG. 41
HORIZONTAL SECTION OF A TOE SPACE



WALL TABLE

FIG. 38b

WALL SCRIBE STRIP INSTALLATION

To scribe a strip to the wall, place one edge on the cabinet and the other edge against the wall. Now take a pair of dividers and adjust them to the widest opening between the edge of the strip and the wall surface. When this measurement has been obtained, start at the top of the strip with one point of the dividers against the wall and the other point held against the surface of the strip, and move the dividers the entire length of the strip (Figure 43).

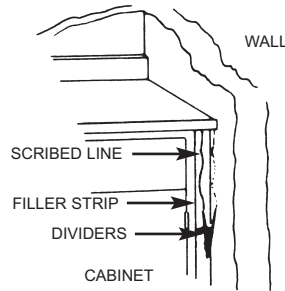

WALL SCRIBING METHOD
FIG. 43

The wall profile will then be scribed on the strip. Using sheet metal shears (for steel) or hand saw (for wood) cut the strip along the scribed line. The strip will then fit smoothly against the wall surface. Attach the strip to the cabinet as previously described for Flush or Overlapping Fillers.

INSTALLATION OF KNEE SPACE PANELS (WOOD)

Knee space panels are used to close an opening between aprons, between units or units and walls. To install, first mount knee space panel cleats on the adjacent base units. Position cleats as shown in Figure 44. Secure to base unit end with a #9 - 1 1/4" flat head wood screw. Next set knee space panel in position against the cleats and attach with #6 - 1 1/4" round head wood screw, (Figure 45).

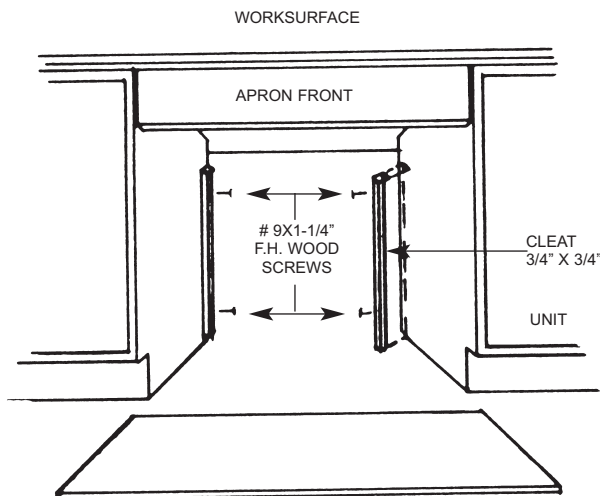

FIG. 44

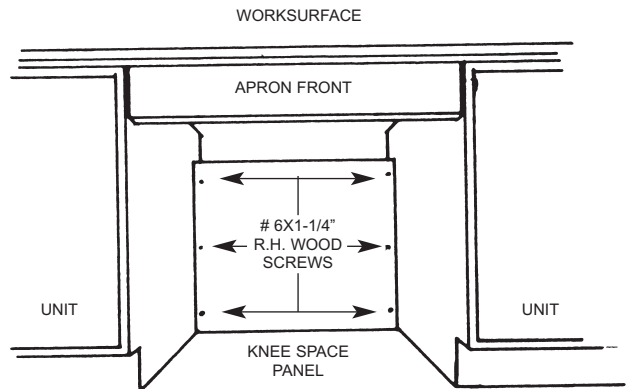

FIG. 45

INSTALLATION OF STEEL SCRIBES AND FILLERS

NOTE: FIGURES FORTY-SIX (46) THROUGH SIXTY-EIGHT (68) RELATE TO STEEL TRIM PIECES ONLY

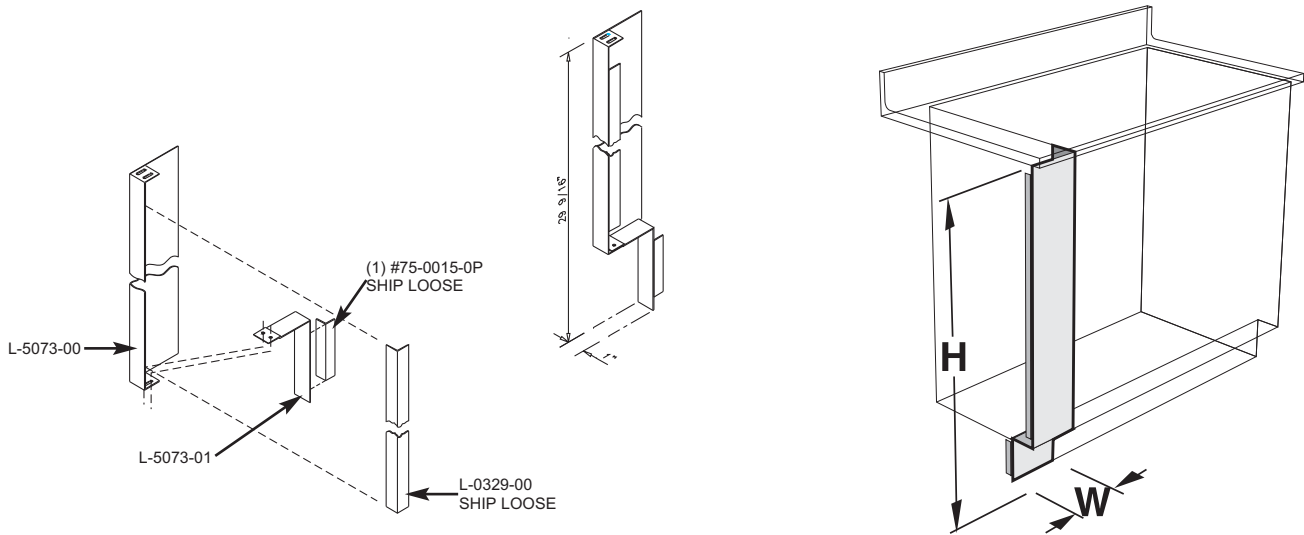

FIG. 46
TO CLOSE OPENING BETWEEN WALL AND FRONT OF
ADJACENT BASE UNITS

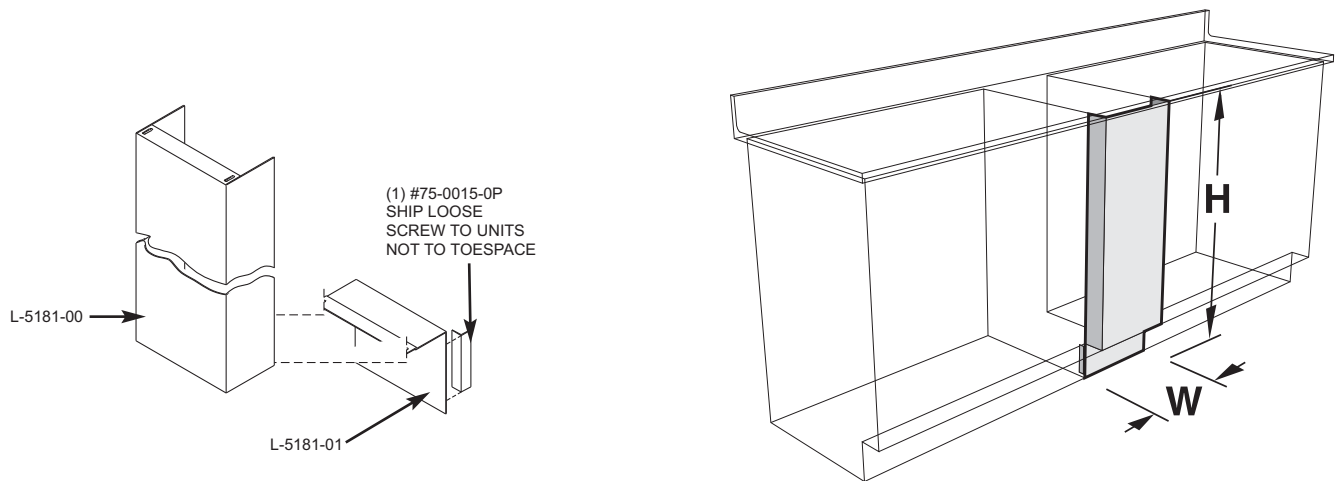

FIG. 47
TO CLOSE OPENING BETWEEN TWO ADJACENT
BASE UNITS

INSTALLATION OF STEEL SCRIBES AND FILLERS

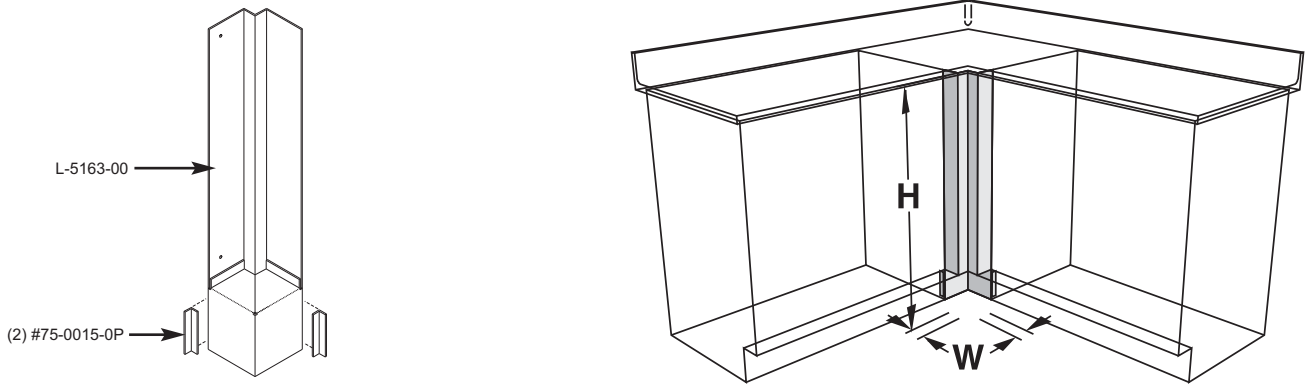

FIG. 48
TO CLOSE OPENING BETWEEN TWO ADJACENT
BASE UNITS JOINED AT RIGHT ANGLES

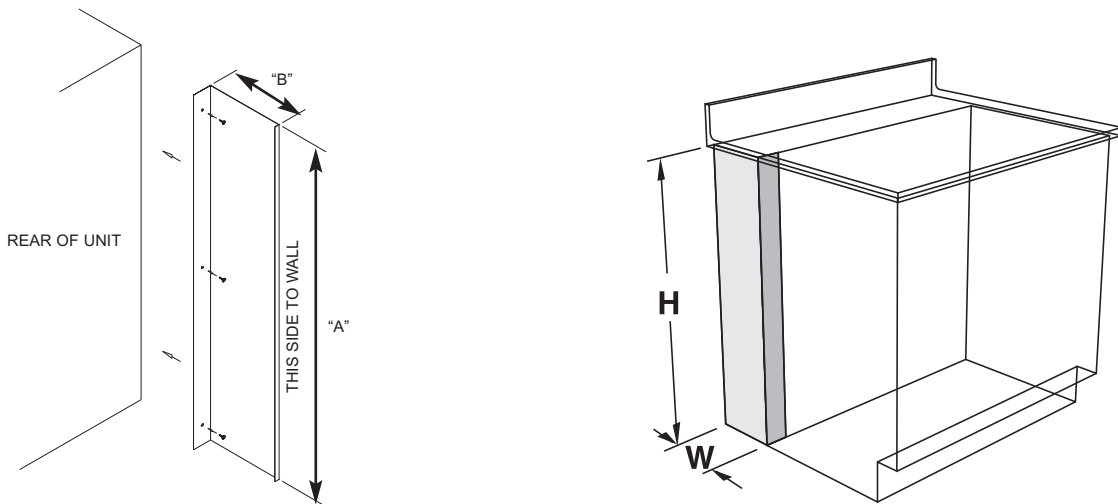

FIG. 49
TO CLOSE OPENING BETWEEN WALL AND REAR OF
ADJACENT BASE UNITS

NOTE: ATTACH TRIM TO BACK OF UNIT PRIOR TO
SETTING UNIT IN PLACE

INSTALLATION OF STEEL SCRIBES AND FILLERS

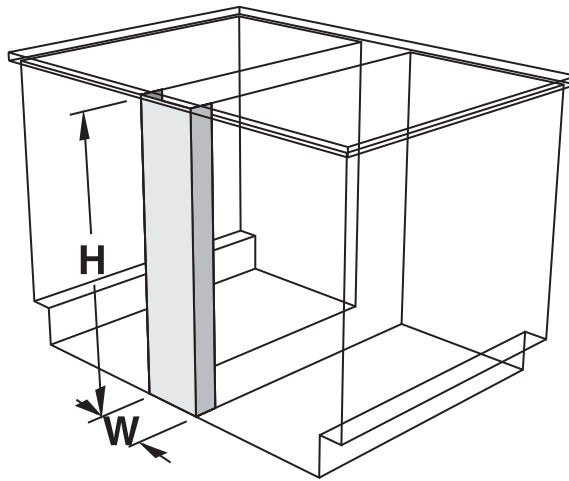

FIG. 50
TO CLOSE OPENING BETWEEN TWO ADJACENT
BASE UNITS INSTALLED BACK TO BACK

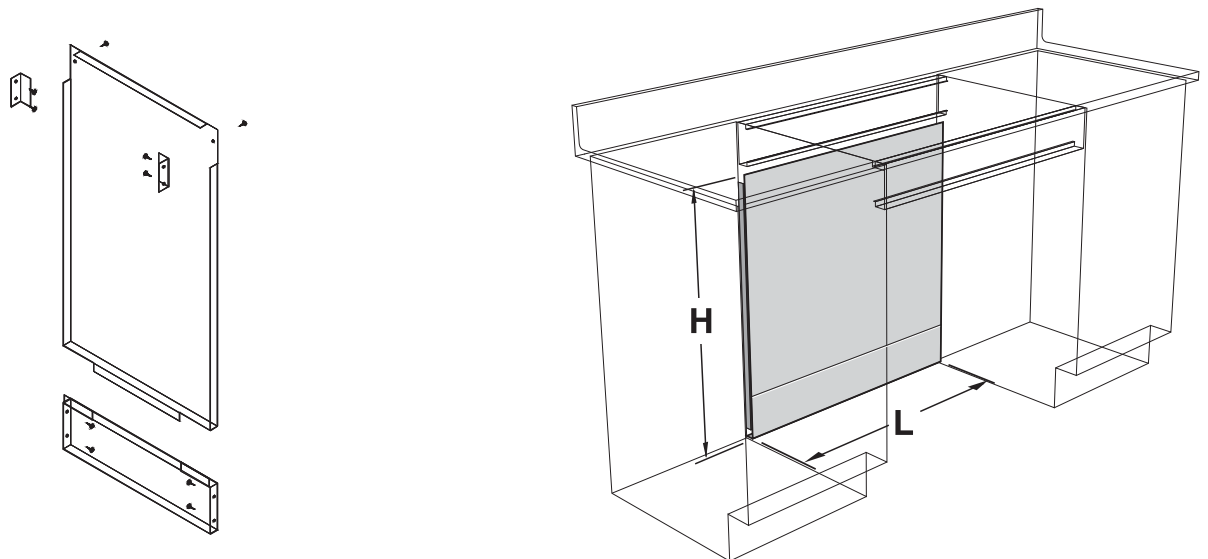

FIG. 51
TO CLOSE OPENING BELOW APRONS AND APRON
RAILS

INSTALLATION OF STEEL SCRIBES AND FILLERS

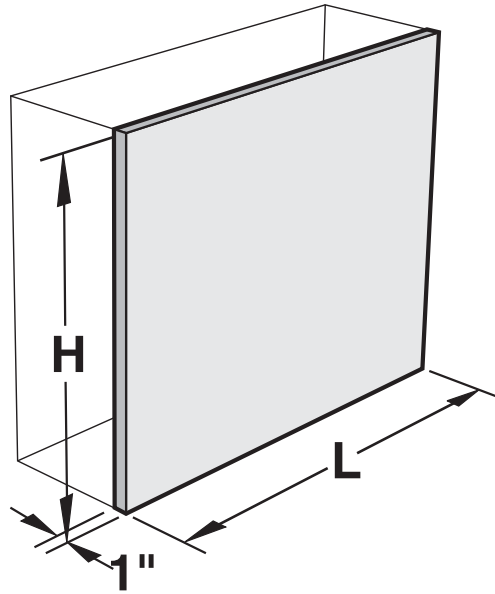

FIG. 54
TO FINISH BACKS OF WALL CABINETS FLUSH

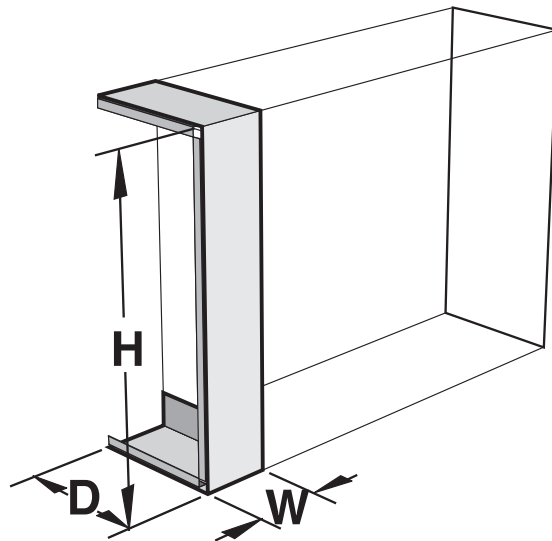

FIG. 55
TO CLOSE OPENING BETWEEN WALL AND FRONT OF
ADJACENT WALL CABINET

INSTALLATION OF STEEL SCRIBES AND FILLERS

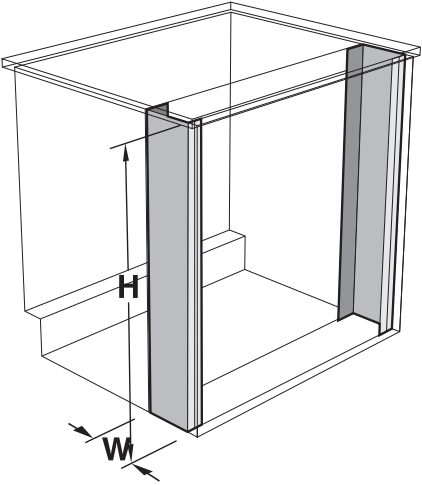

FIG. 52
TO CLOSE AND FINISH PIPE CHASE AREA BEHIND BASE
UNITS ON SINGLE SIDED ISLANDS AND PENINSULAS
(MUST BE USED WITH FINISHED BACK PANELS).

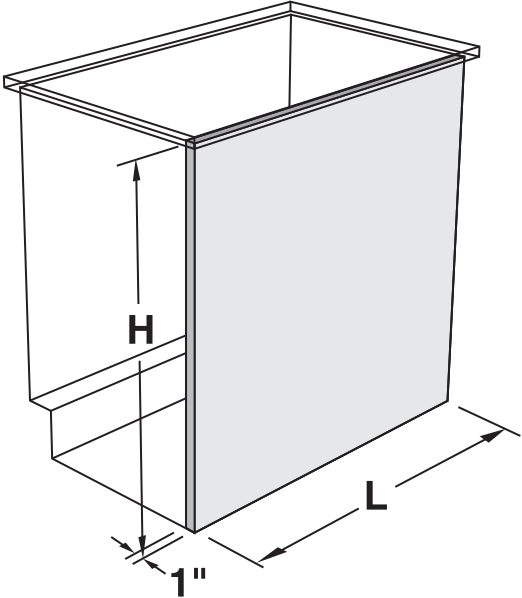
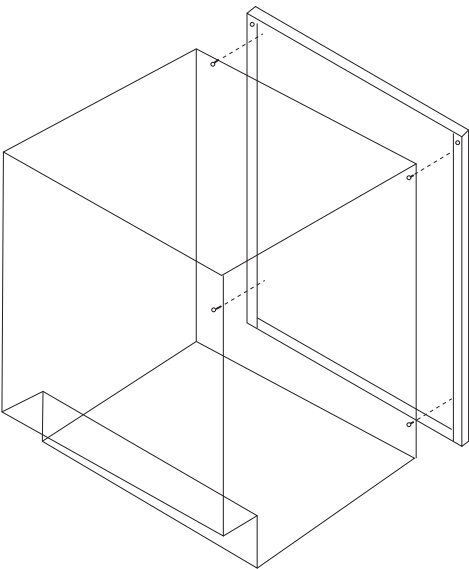

FIG. 53
TO COVER BACKS OF BASE UNITS EXPOSED TO VIEW.
FINISHED BACK MOUNTING DETAILS FOR WALL UNITS
AND FULL HEIGHT UNITS SAME AS BASE UNITS

INSTALLATION OF STEEL SCRIBES AND FILLERS

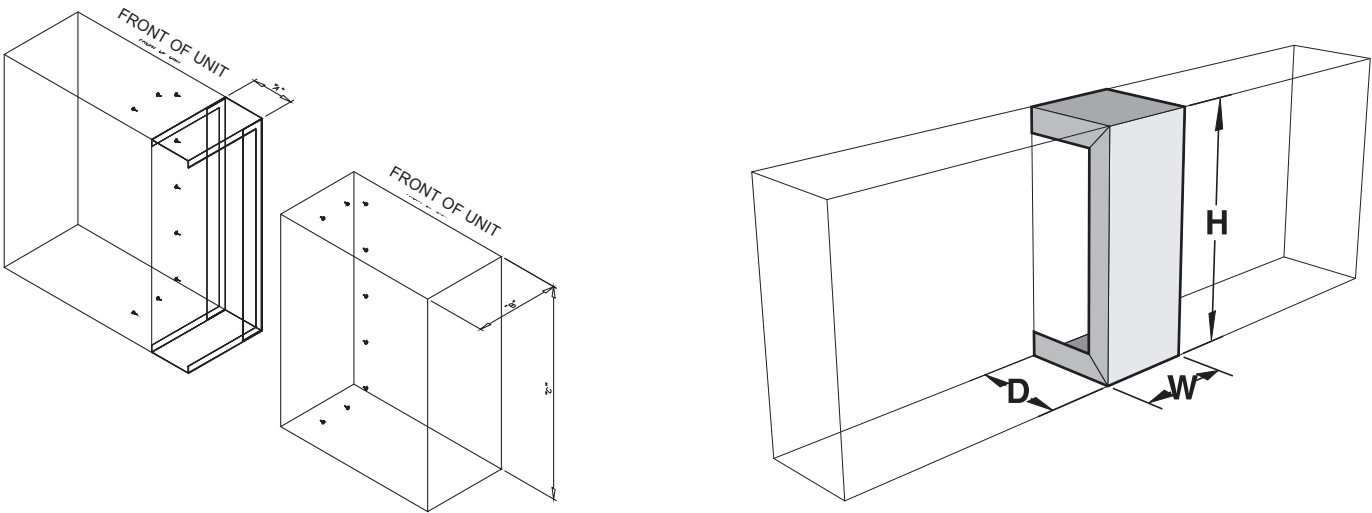

FIG. 56
TO CLOSE OPENING BETWEEN FRONTS OF TWO
ADJACENT WALL CABINETS

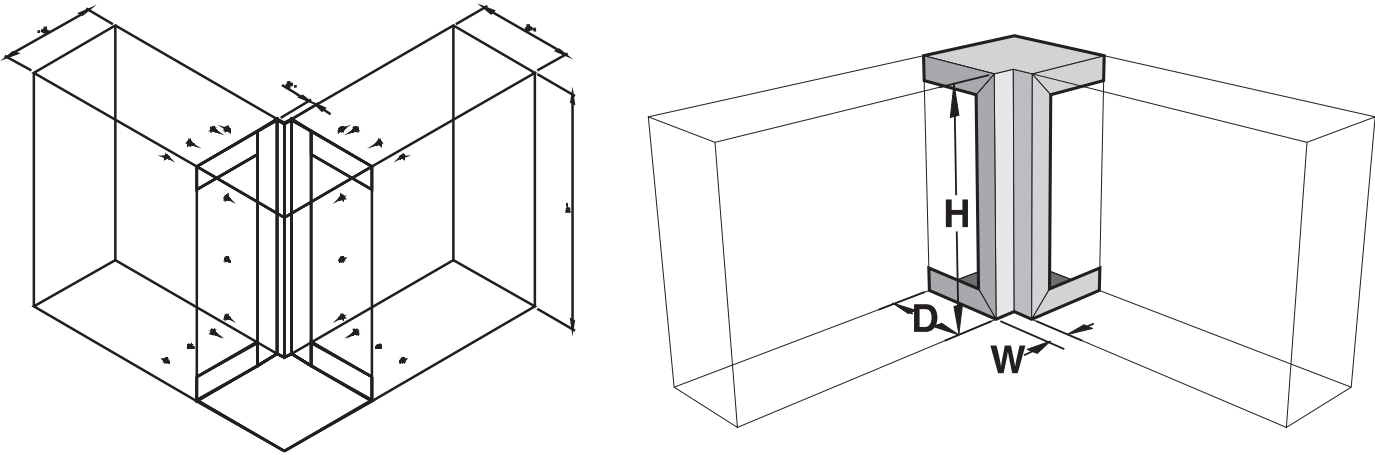

FIG. 57
TO CLOSE OPENING BETWEEN TWO ADJACENT
WALL CABINETS JOINED AT RIGHT ANGLES

INSTALLATION OF STEEL SCRIBES AND FILLERS

NOTE: HOLES NOT PRE-PUNCHED AT FACTORY SHOULD BE DRILLED AT TIME OF INSTALLATION TO ENSURE ACCURACY AND PROPER ADJUSTMENT

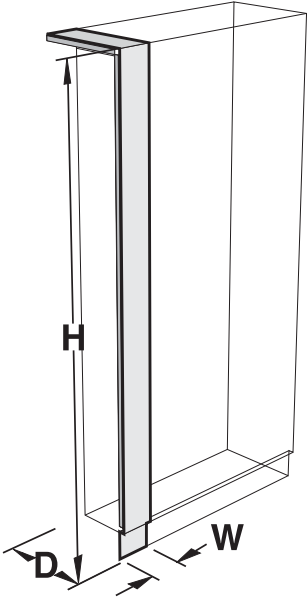
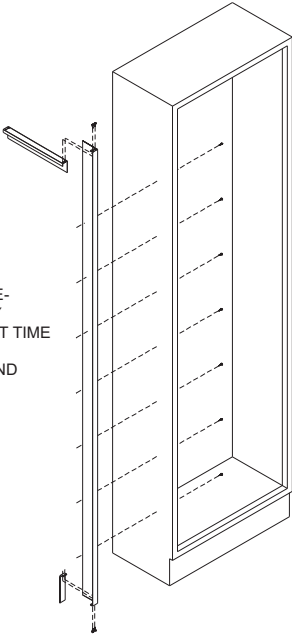

FIG. 58
SCRIBE- TO CLOSE OPENING BETWEEN WALL AND FRONT OF ADJACENT FULL HEIGHT UNIT

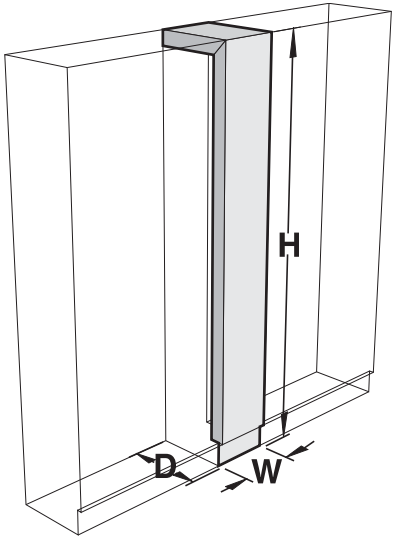

FIG. 59
TO CLOSE OPENING BETWEEN FRONTS OF TWO ADJACENT FULL HEIGHT UNITS

INSTALLATION OF STEEL SCRIBES AND FILLERS

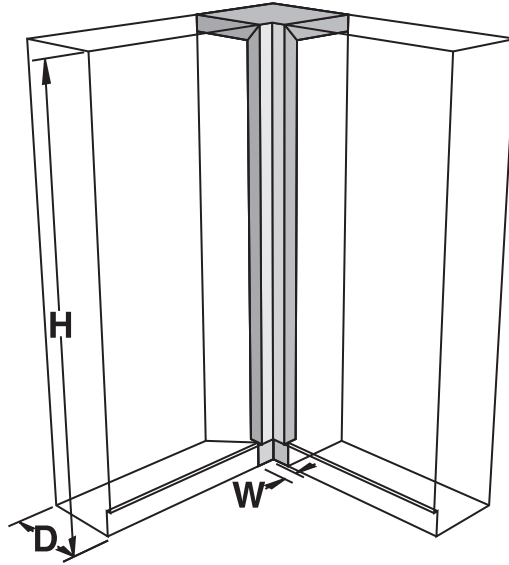

FIG. 60
TO CLOSE OPENING BETWEEN TWO ADJACENT FULL
HEIGHT UNITS JOINED AT RIGHT ANGLES

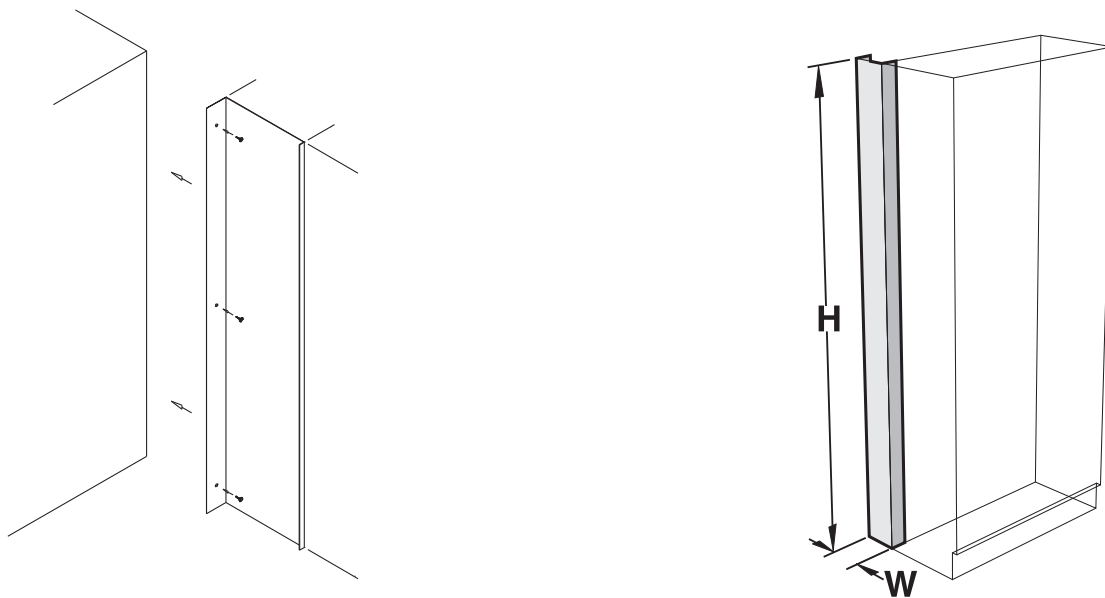

FIG. 61
TO CLOSE OPENING BETWEEN WALL AND REAR OF
ADJACENT FULL HEIGHT UNITS

INSTALLATION OF STEEL SCRIBES AND FILLERS

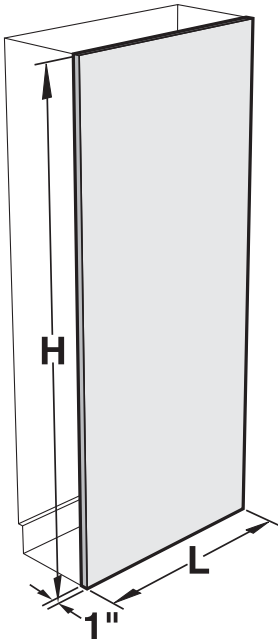

FIG. 62
TO COVER BACKS OF FULL HEIGHT UNITS EXPOSED TO VIEW

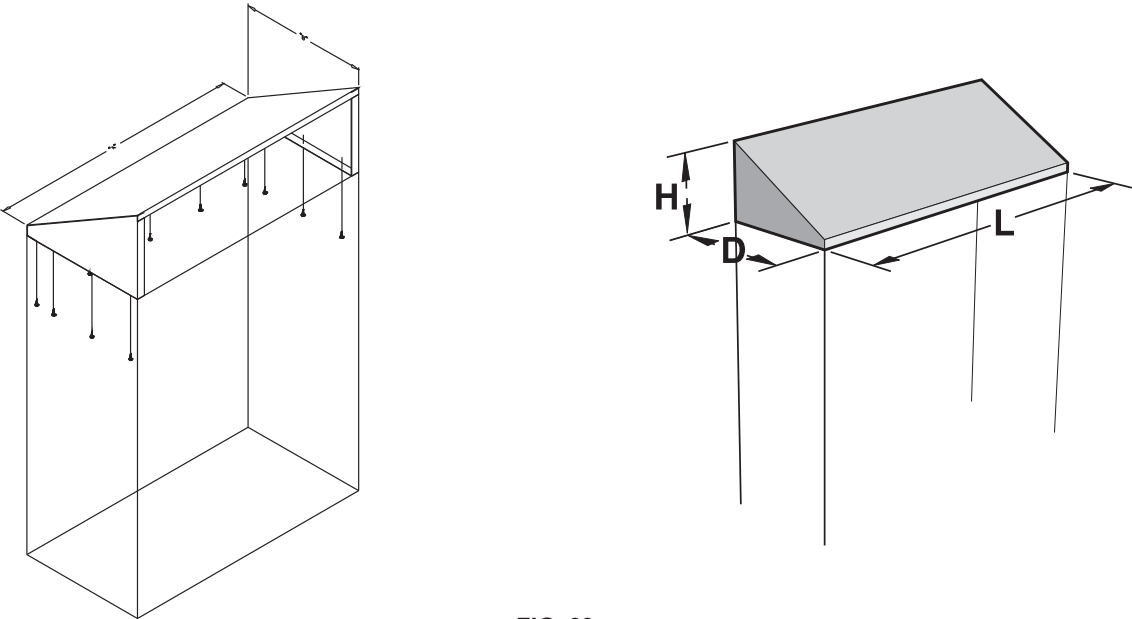

FIG. 63
WALL MOUNTED OR FULL HEIGHT UNIT-SLOPING TOP

INSTALLATION OF STEEL SCRIBES AND FILLERS

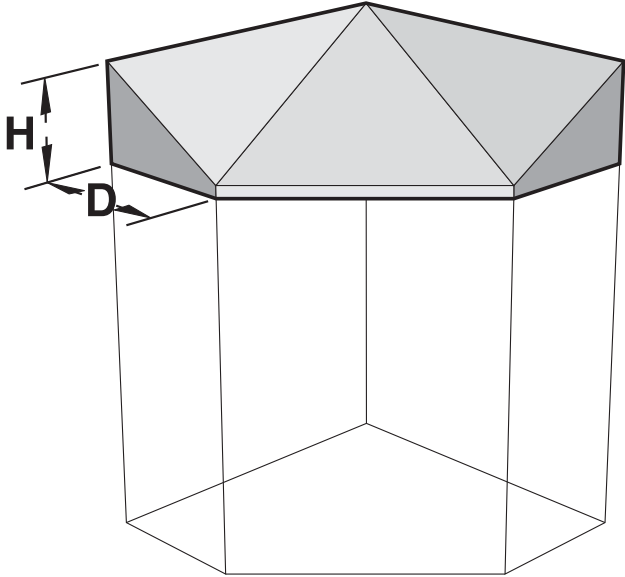

FIG. 64
WALL MOUNTED CORNER UNIT-SLOPING TOP

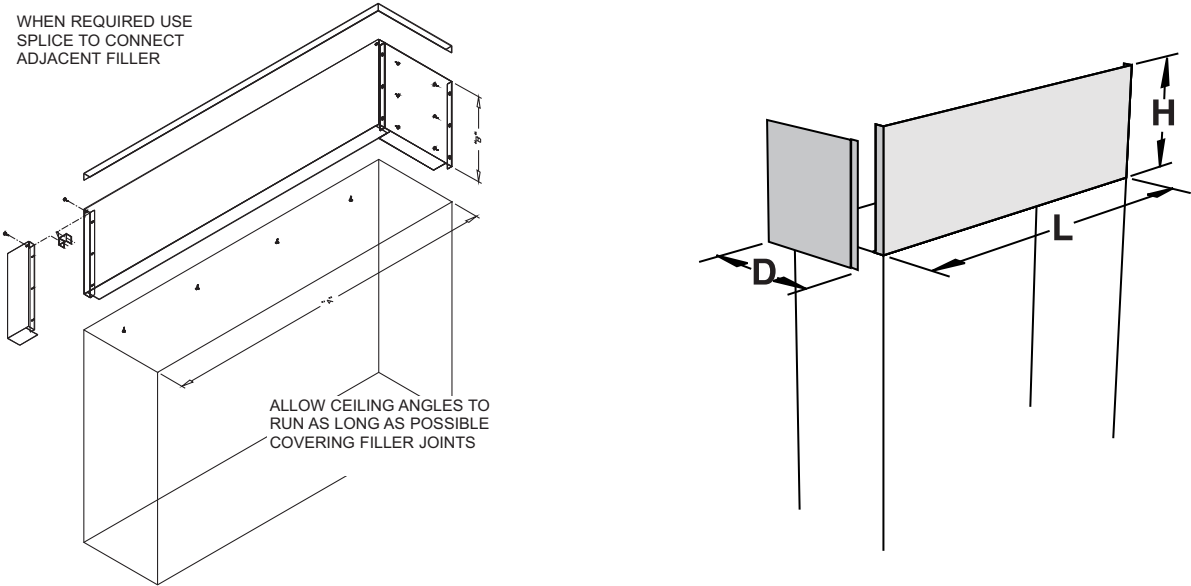

FIG. 65
WALL MOUNTED UNIT OR FULL HEIGHT UNIT-
CEILING ENCLOSURE

INSTALLATION OF STEEL SCRIBES AND FILLERS

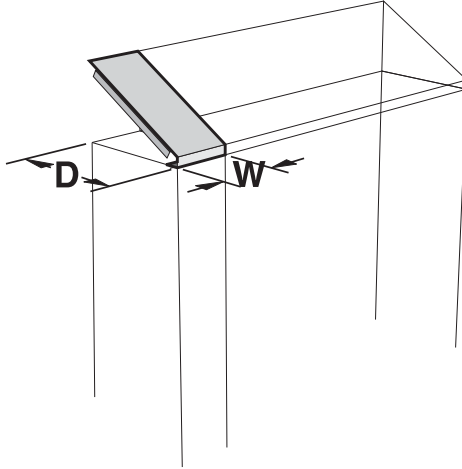

FIG. 66
WALL MOUNTED UNIT OR FULL HEIGHT UNIT-
SLOPING TOP EXTENSION

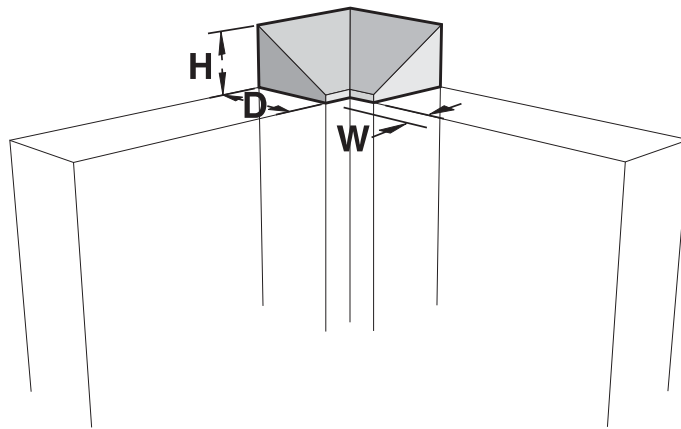
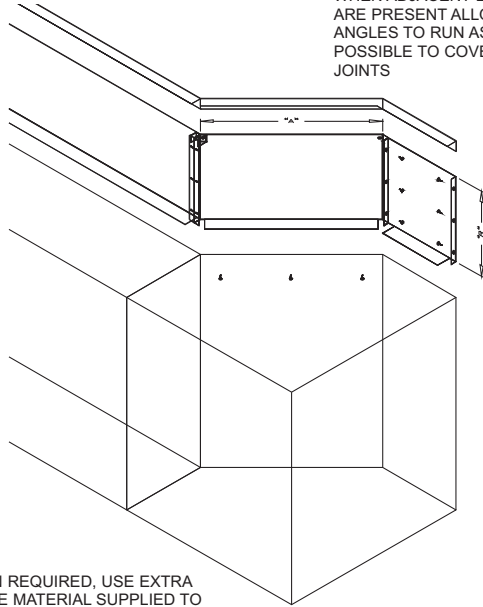

FIG. 67
WALL MOUNTED UNIT OR FULL HEIGHT UNIT-
SLOPING TOP CORNER

INSTALLATION OF STEEL SCRIBES AND FILLERS

WHEN REQUIRED, USE SPLICE
TO CONNECT ADJACENT FILLER

WHEN ADJACENT ENCLOSURES
ARE PRESENT ALLOW CEILING
ANGLES TO RUN AS LONG AS
POSSIBLE TO COVER FILLER
JOINTS



WHEN REQUIRED, USE EXTRA
ANGLE MATERIAL SUPPLIED TO
FINISH END PANEL TO CEILING

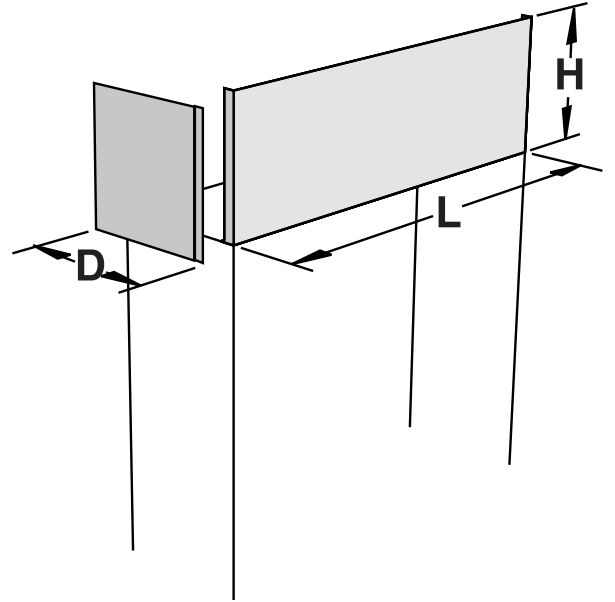

FIG. 68
WALL MOUNTED CORNER UNIT
CEILING ENCLOSURE

PEGBOARD INSTALLATION

Pegboards are fastened to the wall with no less than four (4) fasteners. Fasteners are not furnished due to varying wall conditions. Holes should be drilled in the pegboards using a 1/4" masonry drill. The actual location within pegboard is determined by wall conditions.

When pegboards are installed directly over a table top or curb, seal the joint between the top and pegboard with sealing putty or silicone.

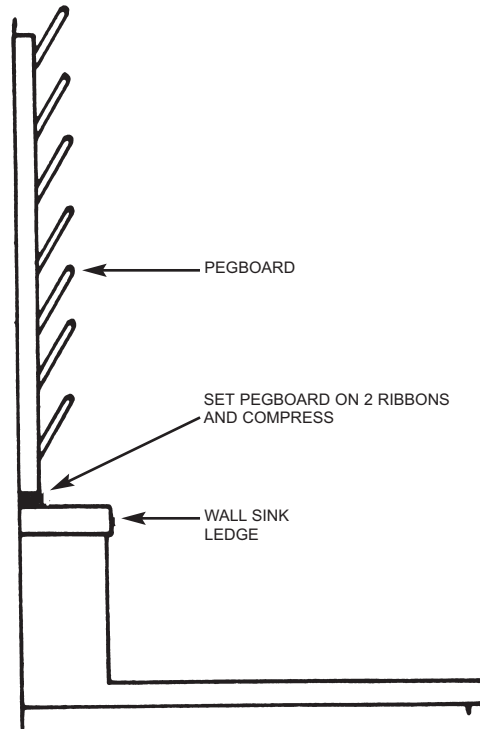

FIG. 69

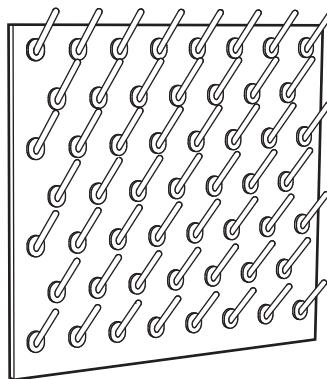

FIG. 70

SELF-ADHESIVE VINYL BASE MOLDING

1. Room temperature during installation should be 75 to 85 degrees F. It is recommended that the base molding be removed from the carton and conditioned to this temperature range prior to actually installing. Good bonding is achieved even if the mounting surface is cold, provided the cove base is between 75 and 85 degrees F.
2. Do not use a solvent of any kind to activate or intensify the initial tack of the adhesive. Solvents tend to deteriorate permanent bonding ability.
3. To ensure a good, tight, permanent bond, the surface should be sound and free of dirt, lint, old paint, etc. In most instances, simply brushing or wiping the surface will be sufficient to clean well enough. If water is used, the mounting surface must be allowed to dry thoroughly, as dampness will prevent bonding of the adhesive.
4. Remove release paper from only one length of base molding at a time during the installation process.
5. Base molding should be positioned so that the toe or bottom edge of the entire length rests on the floor. Start with one end and press against the wall or unit toe space, holding balance of the length away from the mounting surface. Then start from the point of initial contact and press the molding against the surface working toward the trailing end.
6. For succeeding lengths, spot in place tightly against the butt edge of the previous length, keeping the toe or bottom edge parallel with and resting on floor, then install as described above.
7. After the base molding is in place, press the top edge firmly against the mounting surface all the way across the length, working back along the length toward the beginning point or joint with adjacent lengths.
8. Press, rub or roll from center to bottom along the length to assure good contact with the mounting surface at all points. Work back toward joint with preceding length to assure tight fit.
9. After base molding has been applied as close to outside or inside corner as possible, position corner clip and fasten with black oxidized drive screws or nails on wood cabinets.
10. To install corner clips on steel units, drill proper size hole in base rail and install with proper sheet metal corner clip screw.

NOTE: SPECIAL CARE SHOULD BE TAKEN NOT TO STRETCH BASE MOLDING DURING INSTALLATION.

NOTE: ROOM TEMPERATURE DURING INSTALLATION MUST BE AT LEAST 65°F OR MOLDING WILL NOT BOND TO THE CABINET OR WALL.

FINAL ADJUSTMENT OF WOOD FURNITURE

1. Place all removable back panels in place.
2. If it has been necessary to run conduit on plumbing pipe through plumbing space opening, the panels should be cut to fit around these pipes and reinstalled.
3. All shelves in base cabinets should have hold downs removed and shelves installed on their supports.
4. Each item of furniture should be cleaned inside and out and final adjustment made as follows:
 - a. All wood drawer assemblies are pre-fitted to their respective openings at the factory during the installation process they are sometimes removed from their original locations and installed elsewhere. When this happens they may not operate freely. Should this condition exist, remove the drawer and find the drawer originally fitted to the opening and install it there. This should relieve any binding and allow the drawer to work properly. This procedure should be repeated as many times as necessary until all drawers are returned to their original location.
 - b. When doors bind or are uneven, it is usually an indication the units have settled out of level. Cabinets should be re-leveled. Once this is done, door should align and work freely. Re-level by adding or removing shims as needed.
 - c. In some instances, it may be necessary to adjust a hinge to level doors. If this is the case, the hinge should not be moved more than 1/16".
 - d. When adjusting doors, it may be necessary to readjust the magnetic catches. This can be done by loosening mounting screw and moving catch forward or backward, as needed.

FINAL ADJUSTMENT OF STEEL FURNITURE

As a final installation step, each item of furniture should be cleaned and final adjustments made. Adjust drawers to work freely in the case channels without excessive play. Note that the drawer head end of the drawer channels have a locking tab. Heads may be adjusted by loosening screws in taps and tapping with a rubber mallet until head is centered in opening.

FINAL ADJUSTMENT OF STEEL FURNITURE (Continued)

When doors (or drawers) bind as shown in Figure 71, it usually is a sign that the cabinet has settled out of level. Cabinet should be re-leveled by raising or lowering one corner of the unit with the adjustment bolts.

Touch-up paint, if provided, can be used to touch up any scratches or mars in the finish that occurred during handling and installation. When scratches do occur, take a fine camel's hair brush and fill in all scratches and mars with paint, taking care not to get paint on the surrounding area. Once this has been done, paint on touched up area should be dried for approximately 5 minutes with either a standard heat gun or hair dryer. This restores the acid resistance to the touch up paint.

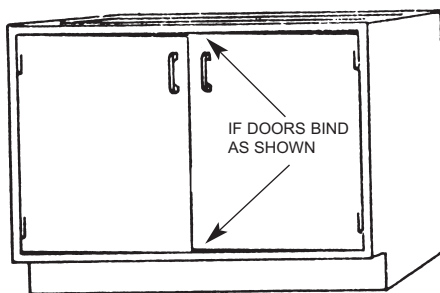











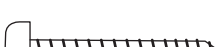







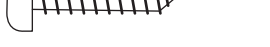



FIG. 71

INSTALLATION OF FUME HOODS

Fume hood installation instructions, operating instructions, maintenance instructions, etc., are covered in separate publications. Therefore, this information is not included in this booklet. Please contact Kewaunee Scientific Corp., (704) 873-7202 for any information of this type.

SUGGESTED HARDWARE

		# 6- 3/8" Jackson Head Screw
		# 6- 1/4" Binding Head Screw
		# 6- 3/4" Round Head Screw
		# 6- 1-1/4" Round Head Screw
		# 9- 1-1/4" Round Head Screw
		# 10- 1" Round Head Screw
		# 10- 1-3/4" Flat Head Screw
		# 10- 2" Flat Head Screw
		# 12- 3/4" Round Head Screw
		# 12- 1-1/4" Oval Head Screw
		# 14- 3/4" Round Head Screw



P.O.Box 1842 •Statesville, NC 28687-1842
(704) 873-7202 •(704) 873-5840
E-mail: marketing@kewaunee.com
www.kewaunee.com