

Self-operated Pressure Regulators

Type 41-23 Universal Pressure Reducing Valve



Application

Pressure regulators for set points from **0.05 to 28 bar** · Valve nominal sizes **DN 15 to 100** · Nominal pressure **PN 16 to 40**
Suitable for liquids, gases and vapors up to **350 °C**

The valve **closes** when the **downstream** pressure rises.



Special features

- Low-maintenance proportional regulators requiring no auxiliary energy
- Frictionless plug stem seal with stainless steel bellows
- Control line kit available for tapping the pressure directly at the valve body
- Wide set point range and convenient set point adjustment using a nut
- Exchangeable actuator and set point springs
- Spring-loaded, single-seated valve with upstream and downstream pressure balancing ¹⁾ by a stainless steel bellows
- Soft-seated plug for high shut-off requirements
- Low-noise standard plug · Special version with flow divider St I or St III (DN 65 to 100) for further noise level reduction (see Data Sheet ▶ T 8081)
- All wetted parts free of non-ferrous metal

Versions

Pressure reducing valve to regulate the downstream pressure p_2 to the adjusted set point. The valve closes when the downstream pressure rises.

Type 41-23 · Standard version

Type 2412 Valve · Valve DN 15 to 100 · Metal-seated plug
Body made of cast iron EN-GJL-250, spheroidal graphite iron EN-GJS-400-18-LT, cast steel 1.0619, forged steel or CrNiMo steel 1.4408

Type 2413 Actuator with EPDM rolling diaphragm

Version with additional features

Pressure reducing valve for low flow rates

Valve with micro-flow trim ($K_{VS} = 0.001$ to 0.04) or special K_{VS} coefficients (restricted cross-sectional area of flow)

Steam pressure reducing valve

With compensation chamber for steam up to 350 °C

Pressure reducing valve with increased safety

Actuator with leakage line connection and seal or two diaphragms and diaphragm rupture indicator · Valve with back-up packing

¹⁾ With $K_{VS} \leq 2.5$: without balancing bellows



Fig. 1: Type 41-23 Universal Pressure Reducing Valve

Special versions

- Control line kit for tapping the pressure directly at the valve body (accessories)
- With internal parts made of FKM, e.g. for use with mineral oils
- EPDM diaphragm with PTFE protective facing
- Actuator for remote set point adjustment (autoclave control)
- Bellows actuator for valves in DN 15 to 100 · Set point ranges 2 to 6, 5 to 10, 10 to 22 or 20 to 28 bar
- Valve with flow divider ST 1 or ST 3 (DN 65 to 100) for particularly low-noise operation with gases and vapors
- Version entirely of stainless steel
- Stainless Cr steel seat and plug with PTFE soft seal (max. 220 °C) · With EPDM soft seal (max. 150 °C)
- Stellite®-faced seat and plug for low-wear operation
- Version for industrial gases

- Free of oil and grease for high-purity applications
- Wetted plastic parts conforming to FDA regulations (max. 60 °C)

Principle of operation (see Fig. 2)

The medium flows through the valve (1) as indicated by the arrow. The position of the plug (3) determines the flow rate across the area released between plug and valve seat (2). The plug stem (5) with the plug is connected to the stem (11) of the actuator (10).

To control the pressure, the operating diaphragm (12) is tensioned by the set point springs (7) and the set point adjuster (6) so that the valve is opened by the force of the set point springs when it is relieved of pressure ($p_1 = p_2$).

The downstream pressure p_2 to be controlled is tapped downstream of the valve and transmitted over the control line (14) to the operating diaphragm (12) where it is converted into a positioning force. This force is used to move the valve plug (3) according to the force of the set point springs (7). The spring force is adjustable at the set point adjuster (6). When the force resulting from the downstream pressure p_2 rises above the adjusted pressure set point, the valve closes proportionally to the change in pressure.

The fully balanced valve has a balancing bellows (4). The downstream pressure p_2 acts on the inside of the bellows, whereas the upstream pressure p_1 acts on the outside of the bellows. As a result, the forces produced by the upstream and downstream pressures acting on the plug are balanced out.

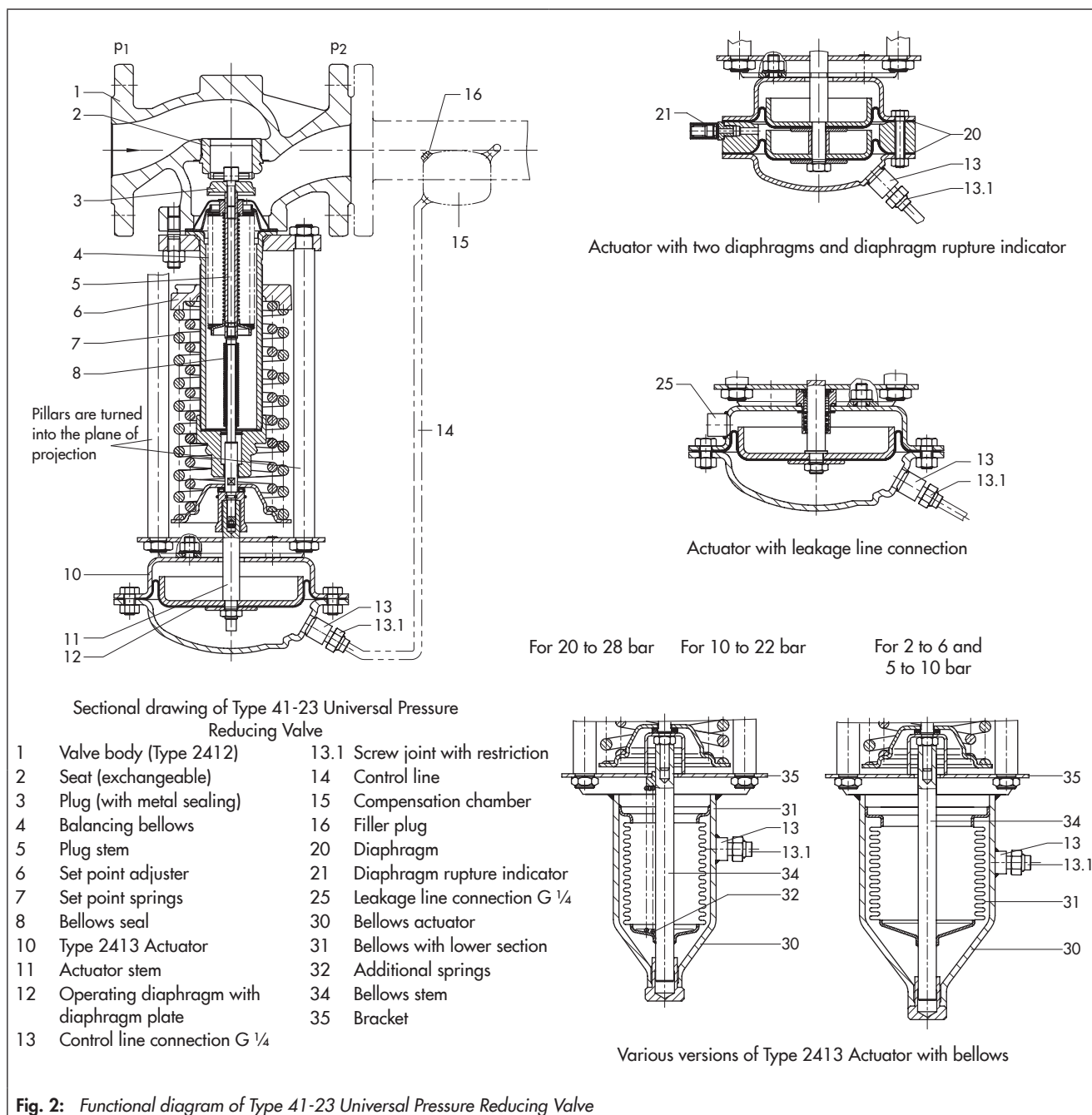

Fig. 2: Functional diagram of Type 41-23 Universal Pressure Reducing Valve

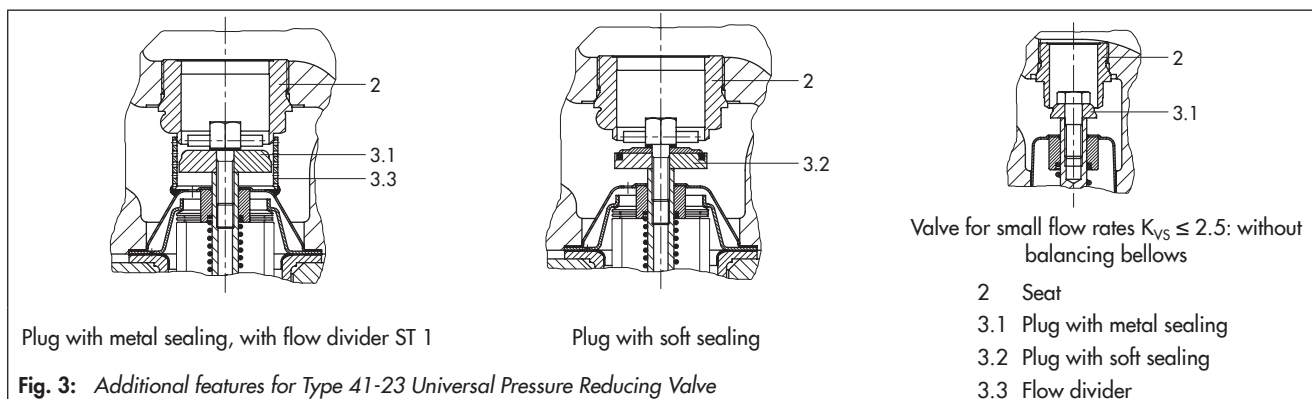

Fig. 3: Additional features for Type 41-23 Universal Pressure Reducing Valve

Table 1: Technical data · All pressures in bar (gauge)

Valve	Type 2412		
Nominal pressure	PN 16, 25 or 40		
Nominal size	DN 15 to 50	DN 65 to 80	DN 100
Max. perm. differential pressure Δp	25 bar	20 bar	16 bar
Max. permissible temperature	See pressure-temperature diagram in ▶ T 2500		
Valve plug	Metal seal: 350 °C · PTFE soft seal: 220 °C · EPDM or FKM soft seal: 150 °C · NBR soft seal: 80 °C		
Leakage class according to IEC 60534-4	Metal seal: Leakage rate I (≤ 0.05 % of K_{VS}) Soft seal: Leakage rate IV (≤ 0.01 % of K_{VS})		
Compliance	CE ENEC		
Diaphragm actuator	Type 2413		
Set point ranges	0.05 to 0.25 bar · 0.1 to 0.6 bar · 0.2 to 1.2 bar 0.8 to 2.5 bar ¹⁾ · 2 to 5 bar · 4.5 to 10 bar · 8 to 16 bar		
Max. permissible temperature	Gases 350 °C, however, max. 80 °C at the actuator · Liquids 150 °C, with compensation chamber max. 350 °C · Steam with compensation chamber max. 350 °C		
Metal bellows actuator	Type 2413		
Effective area	33 cm ²	62 cm ²	
Set point ranges	10 to 22 bar · 20 to 28 bar	2 to 6 bar · 5 to 10 bar	

¹⁾ Version with actuator with two diaphragms: 1 to 2.5 bar

Table 2: Max. permissible pressure at actuator

Set point range · Actuator with rolling diaphragm							Metal bellows actuator			
0.05 to 0.25 bar	0.1 to 0.6 bar	0.2 to 1.2 bar	0.8 to 2.5 bar	2 to 5 bar	4.5 to 10 bar	8 to 16 bar	2 to 6 bar	5 to 10 bar	10 to 22 bar	20 to 28 bar
Max. permissible pressure above the set point adjusted at the actuator										
0.6 bar	0.6 bar	1.3 bar	2.5 bar	5 bar	10 bar	10 bar	6.5 bar	6.5 bar	8 bar	2 bar

Table 3: Materials · Material numbers according to DIN EN

Valve	Type 2412					
Pressure rating	PN 16	PN 25	PN 40			
Max. permissible temperature	300 °C	350 °C	350 °C	350 °C	350 °C	350 °C
Body	Cast iron EN-GJL-250	Spheroidal graphite iron EN-GJS-400-18-LT	Cast steel 1.0619	Stainless steel 1.4408	Forged steel ¹⁾ 1.0460	Forged stainless steel ¹⁾ 1.4571
Seat	CrNi steel			CrNiMo steel	CrNi steel	CrNiMo steel
Plug	CrNi steel			CrNiMo steel	CrNi steel	CrNiMo steel
Seal ring for soft-seated plug	PTFE with 15 % glass fiber · EPDM · NBR · FKM					
Guide bushing	PTFE/graphite					
Balancing bellows and bellows seal	Stainless steel 1.4571					
Actuator	Type 2413					
Diaphragm cases	Sheet steel DD11 (StW22) ²⁾					
Diaphragm	EPDM with fabric insert ³⁾ · FKM for mineral oils · NBR · EPDM with PTFE protective facing					

¹⁾ DN 15, 25, 40, 50 and 80 only

²⁾ In corrosion-resistant version (CrNi steel)

³⁾ Standard version; see Special versions for other diaphragms

Installation

Normally, the valve is installed with the actuator suspended downwards. Install pipelines horizontally with a slight downward slope on both sides of the valve for drainage of the condensate.



- The direction of flow must correspond with the arrow on the valve body.
- The control line must be adapted to match the onsite conditions and is not delivered with the valve. On customer request, a control line kit for pressure tapping directly at the valve body (see Accessories) is available.

For further details on installation, refer to Mounting and Operating Instructions ► EB 2512.

Accessories

Included in the scope of delivery:

- Screw joint with restriction for \varnothing 6 mm control line.

To be ordered separately:

- Compression-type fittings for e.g. 6, 8 or 10 mm pipe
- Control line kit (optionally with or without compensation chamber) for direct attachment to the valve and actuator (pressure tapped directly at the valve body, for set points ≥ 0.8 bar).
- Compensation chamber for condensation and to protect the operating diaphragm against extreme temperatures. A compensation chamber is required for liquids above 150 °C as well as for steam.

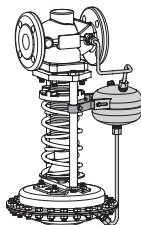

For further details on accessories, refer to ► T 2595.

Dimensions (see Table 5)

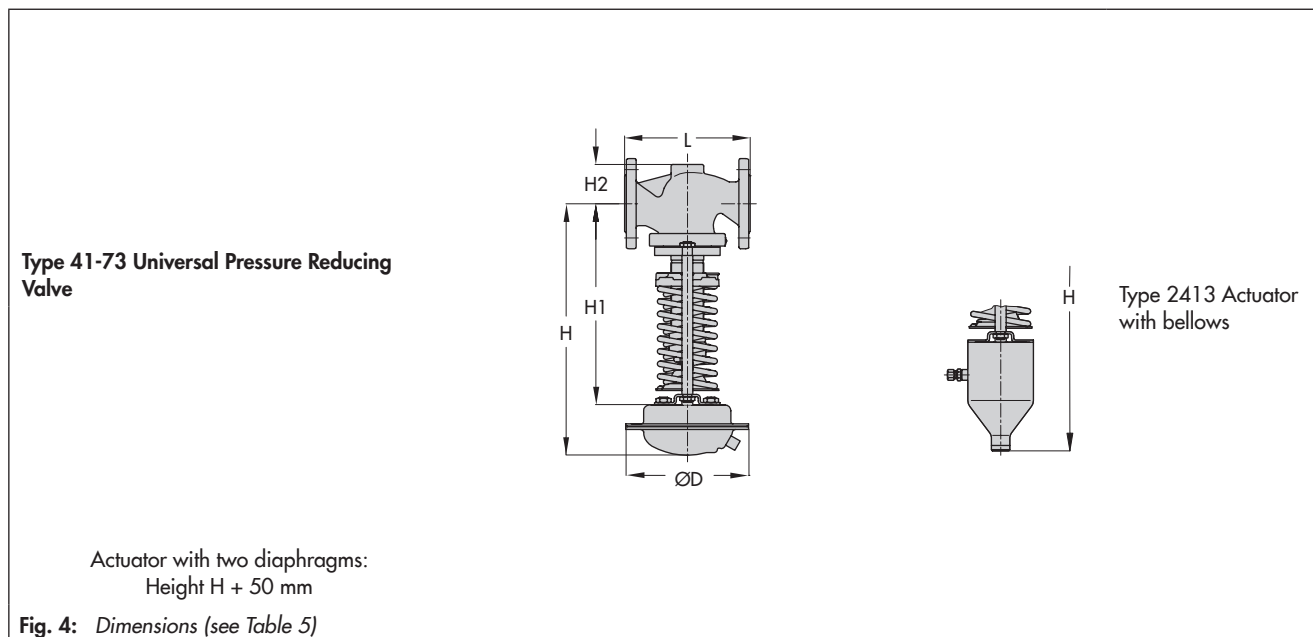

Ordering text

Type 41-23 Universal Pressure Reducing Valve

Additional features ...

DN ...

Body material ..., PN ...

Kvs ...

Set point range ... bar

Optionally, accessories ... (► T 2595)

Optionally, special version ...

Table 4: Weight · Compensation chambers (standard version)

Order no.	Designation	Weight (approx.)
1190-8788	Compensation chamber 0.7 l · Steel	1.6 kg
1190-8789	Compensation chamber 1.5 l · Steel	2.6 kg
1190-8790	Compensation chamber 2.4 l · Steel	3.7 kg

Table 5: Dimensions in mm and weights in kg

Pressure reducing valve		Type 41-23									
Nominal size		DN 15	DN 20	DN 25	DN 32	DN 40	DN 50	DN 65	DN 80	DN 100	
Length L		130	150	160	180	200	230	290	310	350	
Height H1		335			390			510		525	
Height H2	Other materials	44			72			98		118	
	Forged steel	53	–	70	–	92	98	–	128	–	
Standard version with Type 2413 Actuator with rolling diaphragm											
Set point ranges	0.05 to 0.25 bar	Height H	445			500			620		635
		Actuator	ØD = 380 mm, A = 640 cm ²								
		Valve spring force F	1750 N								
	0.1 to 0.6 bar	Height H	445			500			620		635
		Actuator	ØD = 380 mm, A = 640 cm ²								
		Valve spring force F	4400 N								
	0.2 to 1.2 bar	Height H	430			480			600		620
		Actuator	ØD = 285 mm, A = 320 cm ²								
		Valve spring force F	4400 N								
	0.8 to 2.5 bar ²⁾	Height H	430			485			605		620
		Actuator	ØD = 225 mm, A = 160 cm ²								
		Valve spring force F	4400 N								
	2 to 5 bar	Height H	410			465			585		600
		Actuator	ØD = 170 mm, A = 80 cm ²								
		Valve spring force F	4400 N								
	4.5 to 10 bar	Height H	410			465			585		600
		Actuator	ØD = 170 mm, A = 40 cm ²								
		Valve spring force F	4400 N								
8 to 16 bar	Height H	410			465			585		600	
	Actuator	ØD = 170 mm, A = 40 cm ²									
	Valve spring force F	8000 N									
Weight for version with actuator with rolling diaphragm											
Set point ranges	0.05 to 0.6 bar	Weight, based on cast iron ¹⁾ , approx. kg	22.5	23.5	29.5	31.5	35	51	58	67	
	0.2 to 2.5 bar		16	18	23.5	25.5	29	45	52	61	
	2 to 16 bar		12	13	18.5	21	24	40	47	56	
Version with Type 2413 Actuator with bellows											
Set point ranges	2 to 6 bar	Height H	550			605			725		740
		Actuator	A = 62 cm ²								
		Valve spring force F	4400 N								
	5 to 10 bar	Height H	550			605			725		740
		Actuator	A = 62 cm ²								
		Valve spring force F	8000 N								
	10 to 22 bar	Height H	535			590			710		725
		Actuator	A = 33 cm ²								
		Valve spring force F	8000 N								
	20 to 28 bar	Height H	535			590			710		725
		Actuator	A = 33 cm ²								
		Valve spring force F	8000 N								
Weight for version with bellows actuator											
A = 33 cm ²	Weight, based on cast iron ¹⁾ , approx. kg	16.5	17.9	18	23.5	25.5	29	48	56	66	
A = 62 cm ²		20.9	21.5	22	27.5	29.5	33	54	65	75	

¹⁾ +10 % for cast steel, spheroidal graphite iron and forged steel

²⁾ Version with actuator with two diaphragms: 1 to 2.5 bar

Table 6: K_{VS} coefficients and x_{FZ} values · Terms for noise level calculation according to VDMA 24422 (edition 1.89)

Nominal size	$K_{VS}^{1)}$	x_{FZ}	$K_{VS}^{1)}$	x_{FZ}	$K_{VS} 1$	$K_{VS} 3$
	Standard version		Special version		With flow divider	
DN 15			0.1 · 0.4 · 1	0.7 · 0.65 · 0.6		
			2.5	0.55		
	4	0.5			3	
DN 20			0.1 · 0.4 · 1	0.7 · 0.65 · 0.6		
			2.5	0.55		
			4	0.5		
	6.3	0.45			5	
DN 25			0.1 · 0.4 · 1	0.7 · 0.65 · 0.6		
			2.5	0.55		
	8	0.4	4 · 6.3	0.5 · 0.45	6	
DN 32			6.3 · 8	0.45 · 0.4		
	16	0.4			12	
DN 40			6.3 · 8	0.45 · 0.4		
	20	0.4	16	0.4	15	
DN 50			8	0.4	6	
	32	0.4	16 · 20	0.45 · 0.4	25	
DN 65			20 · 32	0.4	25	
	50	0.4			38	25
DN 80			32	0.4	25	
	80	0.35	50	0.4	60	40
DN 100			50	0.4	38	
	125	0.35			95	60

¹⁾ With K_{VS} 0.001 to 0.04: Valve with micro-trim (DN 15 to 25) without balancing bellows

Valve-specific correction terms

ΔL_G · For gases and vapors:

Values as specified in the diagram

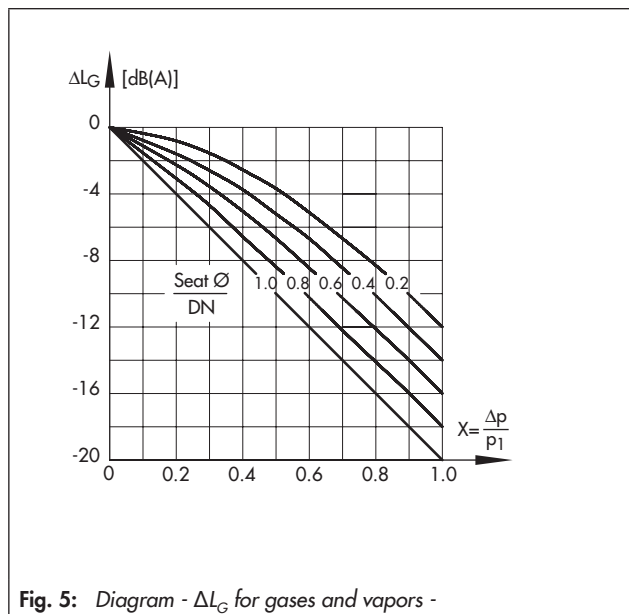

Fig. 5: Diagram - ΔL_G for gases and vapors -

Specifications subject to change without notice

ΔL_F · For liquids:

$$\Delta L_F = -10 \cdot (x_F - x_{FZ}) \cdot y$$

$$\text{with } x_F = \frac{\Delta p}{p_1 - p_V} \text{ and } y = \frac{K_V}{K_{VS}}$$

Terms for control valve sizing according to IEC 60534, Parts 2-1 and 2-2:

$$F_L = 0.95; x_T = 0.75$$

x_{FZ} · Acoustical valve coefficient

$K_{VS} 1, K_{VS} 3$ · When a flow divider ST 1 or ST 3 is installed as a noise-reducing component

Flow characteristic differences between valves with and valves without flow dividers do not occur until the valve has passed through approx. 80 % of its travel range.

