

MR772
MR773

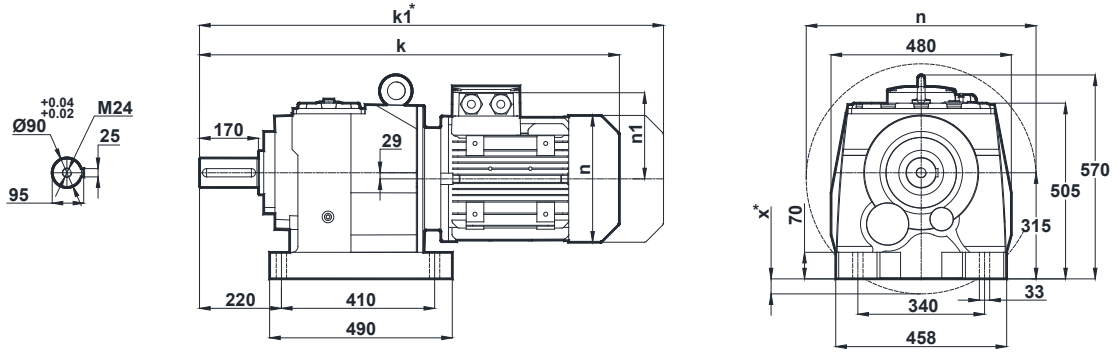

NR772
NR773

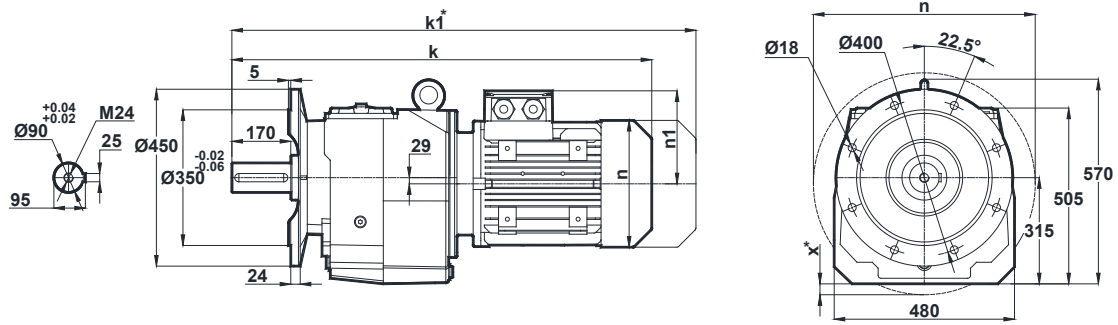

| Motor Büyüklüğü / Motor Size / Motorbaugroße | | | | | | | | | | |
|--|------|------|------|------|--------|--------|--------|------|------|--------|
| | 132S | 132M | 160M | 160L | 180M | 180L | 200L | 225S | 225M | 250M |
| k | 1001 | 1001 | 1097 | 1097 | 1168 | 1168 | 1210 | 1237 | 1262 | 1366 |
| k1 | 1131 | 1131 | 1277 | 1277 | 1338.5 | 1338.5 | 1396.5 | 1402 | 1427 | 1536.5 |
| n | 257 | 257 | 315 | 315 | 347 | 347 | 390 | 434 | 434 | 480 |
| n1 | 179 | 179 | 219 | 219 | 234 | 234 | 275 | 285 | 285 | 322 |
| x | - | - | - | - | - | - | - | - | - | - |

Klemens Kutusu / Terminal Box / Klemmenkasten

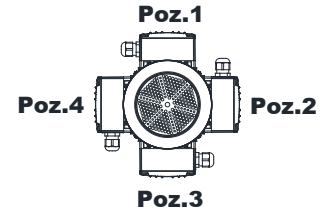

132-160-180-200-225-250

Opsiyonel Flanş Ölçüleri / Optional Flange Dimensions / Auswählbare Flanschabmessungen

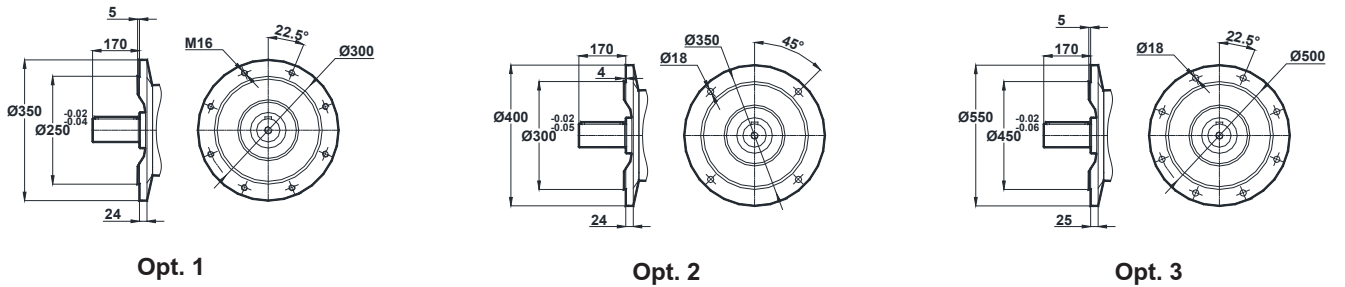

* " k1 " Ölçüsü frenli redüktörlere aittir. Dimension " k1 " is for motors with brake. Maße " k1 " ist für Bremsenmotoren.
x: Motor, ayak bağlantı yüzeyinin altında ise / x: If Motor is lower than foot mounting plane / x: Wenn der Motor unter der Fußmontageebene ist