

MR272
MR273

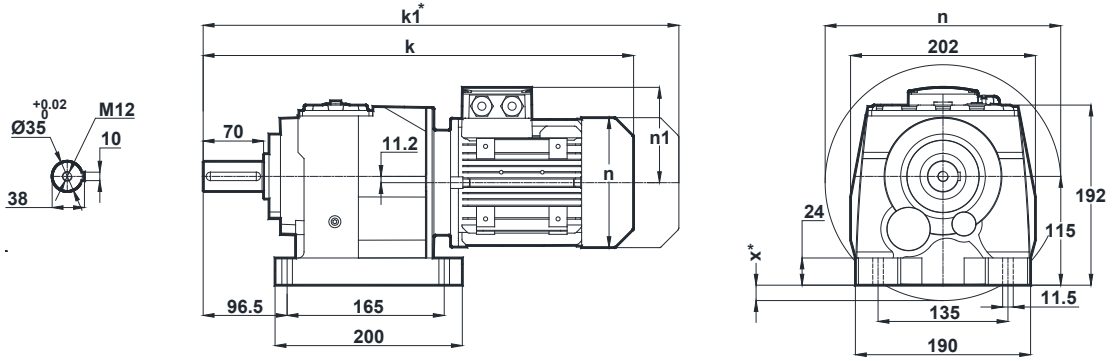

NR272
NR273

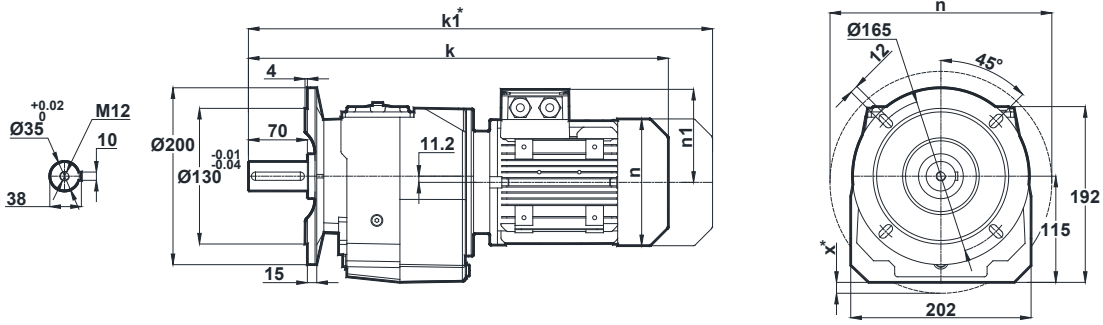

Motor Büyüklüğü / Motor Size / Motorbaugroße									
	63	71	80	90S	90L	100L	112M	132S	132M
k	443	471	505	544	544	592	616	698	698
k1	504	562	598	648.5	648.5	711.5	720.5	828	828
n	121	137	155	176	176	193	215	257	257
n1	97	112	121	132	132	147	158	179	179
x	-	-	-	-	-	-	4	25	25

Klemens Kutusu / Terminal Box / Klemmenkasten

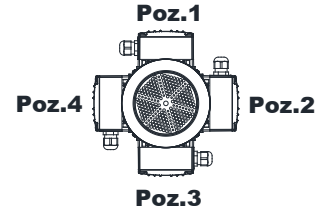

63-71-80-90-100-112-132

Opsiyonel Flanş Ölçüleri / Optional Flange Dimensions / Auswählbare Flanschabmessungen

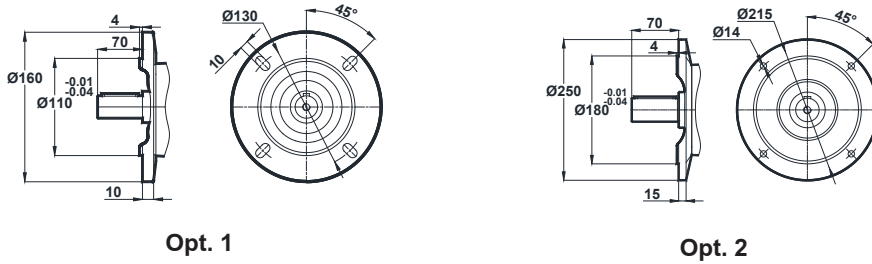

* " k1 " Ölçüsü frenli redüktörlere aittir. Dimension " k1 " is for motors with brake. Maße " k1 " ist für Bremsenmotoren.

x: Motor, ayak bağlantı yüzeyinin altında ise / x: If Motor is lower than foot mounting plane / x: Wenn der Motor unter der Fußmontageebene ist