

MR572
MR573

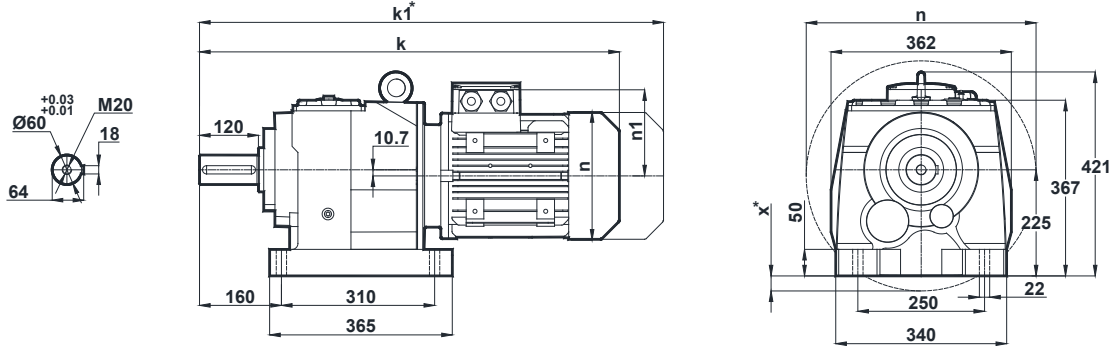

NR572
NR573

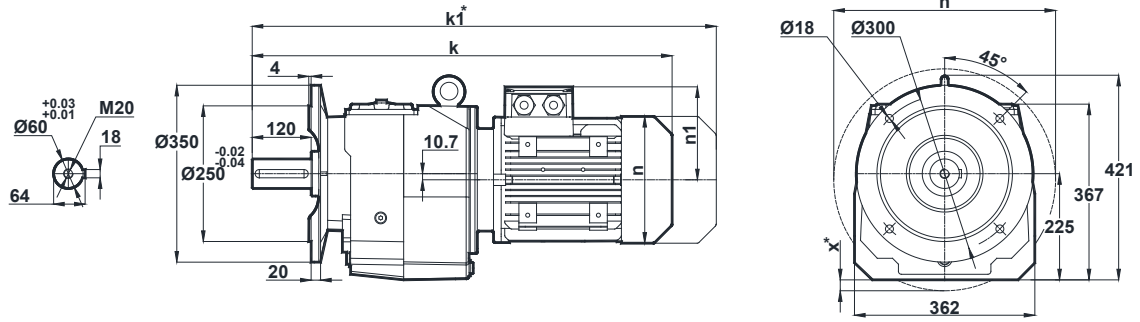

Motor Büyüklüğü / Motor Size / Motorbaugroße									
	100L	112M	132S	132M	160M	160L	180M	180L	200L
k	752	776	863	863	959	959	1030	1030	1072
k1	871.5	880.5	993	993	1139	1139	1200.5	1200.5	1258.5
n	193	215	257	257	315	315	347	347	390
n1	147	158	179	179	219	219	234	234	275
x	-	-	-	-	-	-	-	-	-

Klemens Kutusu / Terminal Box / Klemmenkasten

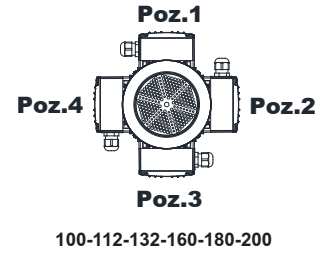

Opsiyonel Flanş Ölçüleri / Optional Flange Dimensions / Auswählbare Flanschabmessungen

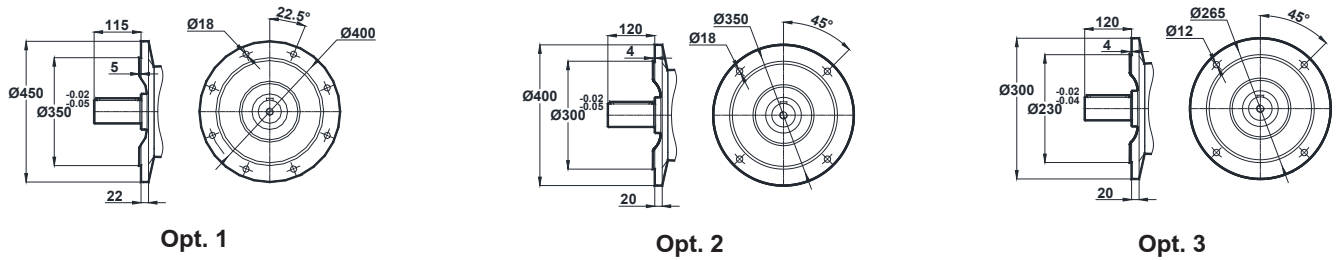

* "k1" Ölçüsü frenli redüktörlere aittir. Dimension "k1" is for motors with brake. Maße "k1" ist für Bremsenmotoren.
x: Motor, ayak bağlantı yüzeyinin altında ise / x: If Motor is lower than foot mounting plane / x: Wenn der Motor unter der Fußmontageebene ist