

# EN080.00

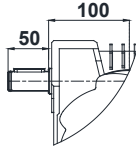

Opsiyonel / Optional / Auswählbar  
EN080.00-06

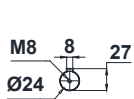
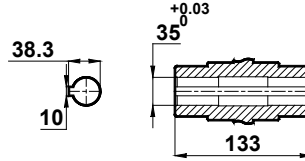
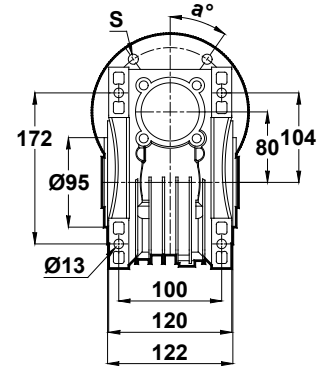
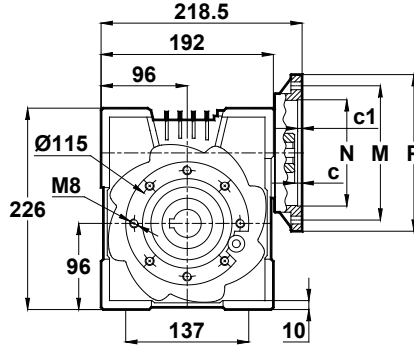

EN080	c	c1	N	M	P	d	u	t	a	s
80/B14	5,5	5	80	100	120	19	21,8	6	45°	7
90/B14	5,5	5	95	115	140	24	27,3	8	45°	9
100-112/B14	5,5	5	110	130	160	28	31,3	8	45°	9
80/B5	5,5	4,5	130	165	200	19	21,8	6	45°	13
90/B5	5,5	4,5	130	165	200	24	27,3	8	45°	13
100-112/B5	5,5	4,5	180	215	250	28	31,3	8	45°	13

-Mil ucu çekirtme deliği DIN 332 sayfa 2 / Tapped center hole to DIN 332, sheet 2 / Zentrierung mit Gewinde DIN 332, Blatt 2