

MR472
MR473

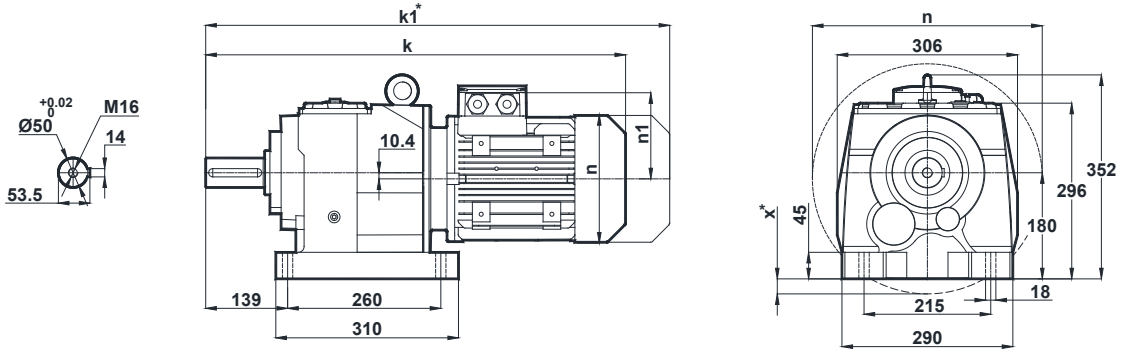

NR472
NR473

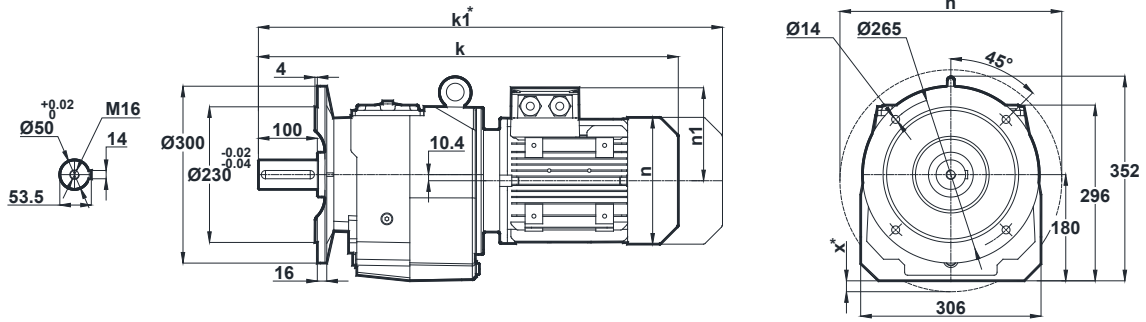

Motor Büyüklüğü / Motor Size / Motorbaugroße											
	80	90S	90L	100L	112M	132S	132M	160M	160L	180M	180L
k	611	650	650	694	719	804	804	900	900	971	971
k1	704	754.5	754.5	813.5	823.5	934	934	1080	1080	1141.5	1141.5
n	155	176	176	193	215	257	257	315	315	347	347
n1	121	132	132	147	158	179	179	219	219	234	234
x	-	-	-	-	-	-	-	-	-	3	3

Klemens Kutusu / Terminal Box / Klemmenkasten

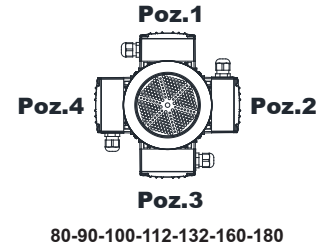

Opsiyonel Flanş Ölçüleri / Optional Flange Dimensions / Auswählbare Flanschabmessungen

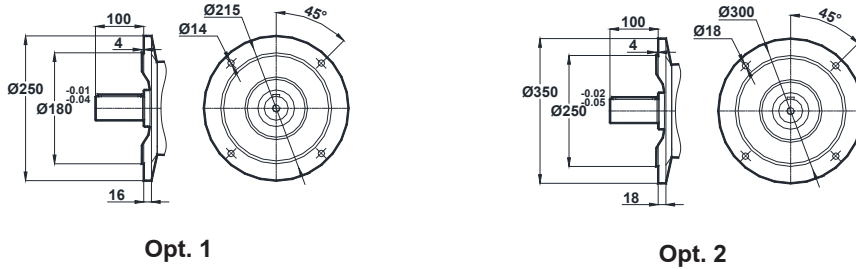

* " k1 " Ölçüsü frenli redüktörlere aittir. Dimension " k1 " is for motors with brake. Maße " k1 " ist für Bremsenmotoren.

x: Motor, ayak bağlantı yüzeyinin altında ise / x: If Motor is lower than foot mounting plane / x: Wenn der Motor unter der Fußmontageebene ist