

Product description	<b>Contacts: 6, cable plug connector, right-turning (the pin and socket insert counter-rotate in right and left turning models)</b>
Area	<b>M23 Power Series 623</b>
Order number	<b>99 4635 00 06</b>

**Illustration**

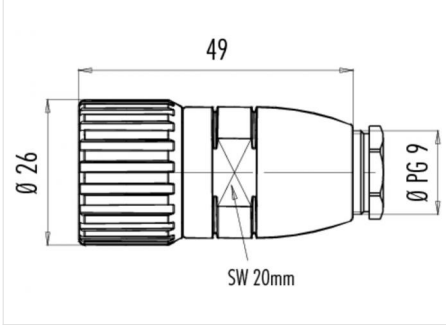

**Scale drawing**



**Contact arrangement**

	X	Y
1	4,13	2,38
2	4,13	-2,38
3	0,00	-4,75
4	-4,13	-2,38
5	-4,13	2,38
6	0,00	0,00

You can find the assembly instructions on the next page.

**Technical data**

**General values**

Connector design	Cable Connector
Connector locking system	bolted
Termination	solder
Wire gauge (mm)	2,50 mm <sup>2</sup>
Wire gauge (AWG)	14
Cable outlet	6 - 10 mm
Upper limit temperature	125 °C
Lower limit temperature	-20 °C

**Electrical values**

Rated voltage	300 V
Rated impulse voltage	2500 V
Pollution degree	3
Overvoltage category	II
Insulating material group	III
Rated current (40 °C)	20 A
Volume resistivity	≤ 3 mΩ
EMC compliance	Shielding is not possible
Degree of protection	IP67
Mechanical operation	> 50 Mating cycles

**Material**

Contact material	CuZn (Messing)
Contact plating	Au (gold)
Contact body material	PBT/PA66

Product description	<b>Contacts: 6, cable plug connector, right-turning (the pin and socket insert counter-rotate in right and left turning models)</b>
Area	<b>M23 Power Series 623</b>
Order number	<b>99 4635 00 06</b>

### Assembly instructions / Panel cut-out

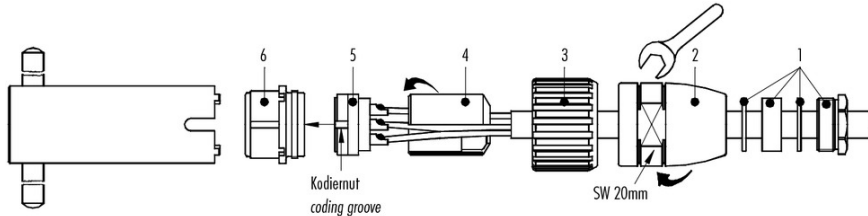

- Kabelverschraubung Pos. 1, Adapter Pos. 2 und Überwurfmutter Pos. 3 auf das Kabel schieben.
- Kabel-Außenmantel 20 mm abisolieren.
- Folie, Füller und innere Isolierungen abschneiden.
- Litzen 3,5 mm abisolieren, verdrehen und verzinnen.
- Litzen an Kontakte löten, crimpen oder schrauben.
- Distanzhülse Pos. 4 einfügen.
- Einsatz Pos. 5 und Distanzhülse Pos. 4 in Einsatzzing Pos. 6 einführen. Hierbei ist zu beachten, daß die gewünschte Kodiernut des Einsatzes Pos. 6 in den Kodiersteg eingeführt wird.
- Adapter Pos. 2 Festschrauben auf Anschlag.
- Kabelverschraubung Pos. 1 Festschrauben.

- Push the cable screw connection (1), adapter (2) and coupling nut (3) onto the cable.
- Strip the cable coating by 20 mm.
- Trim foil, filler and inner insulation.
- Strip the single wires by 3.5 mm, twist and tin.
- Solder, crimp or screw the single wires to the contacts.
- Insert the distance shell (4).
- Guide the insert (5) and distance shell (4) into the insert ring (6), mind that the desired coding groove of the insert (6) is pushed into the coding bar.
- Screw the adapter (2) as tight as possible.
- Screw the cable gland (1) as tight as possible.

Anzugsdrehmoment für Klemmschraube Kontakteinsatz Pos. 5 mit Schraubkontakten beachten:

- max. 0,1 Nm für Schraubkontakte Steckdurchmesser 1 mm
- max. 0,2 Nm für Schraubkontakte Steckdurchmesser 2 mm

Please note: torque for clamping screw for contact insert (5) with screw contacts:

- max. 0.1 Nm for screw contacts with mating dia. 1 mm
- max. 0.2 Nm for screw contacts with mating dia. 2 mm

Product description	<b>Contacts: 6, cable plug connector, right-turning (the pin and socket insert counter-rotate in right and left turning models)</b>
Area	<b>M23 Power Series 623</b>
Order number	<b>99 4635 00 06</b>

### Sicherheitshinweise

1. The connector must not be connected or separated under load. Non-observance and incorrect use can result in personal injury.
2. The connectors are designed for use in plant, control system and electrical equipment. The end user is responsible for checking whether the connectors are suitable for use in other applications.
4. Connectors used in electrical circuits containing hazardous life parts must only be assembled and used by or under the supervision of persons with the requisite electrotechnical training, taking the applicable regulations and standards into account.
6. Connectors with degree of protection IP 67 and IP 68 are not suitable for use under water. When used outdoors, the connectors must be separately protected against corrosion. For further information about IP degrees of protection refer to 'Technical support' in the Download Centre.
8. To lock the cable connector to the equipment connector, the threaded ring is tightened until it is 'finger-tight' (approx. 50 cNm).