



memmert
Experts in Thermostatics

Heating and drying ovens

COMMUNICATION. COMFORT. SIMPLY GREAT.



UNIVERSAL OVEN U
PASS-THROUGH OVEN UF TS
PARAFFIN OVEN UNpa
STERILISER S
VACUUM OVEN VO
COOLED VACUUM OVEN VOcool

100% ATMOSAFE. MADE IN GERMANY.

www.memmert.com | www.atmosafe.net

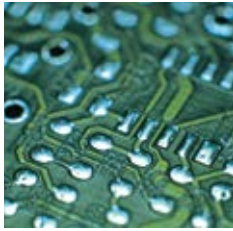

Simply boundless. Boundlessly simple.

Drying, heating, ageing, testing, sterilising,
burning-in, curing, storing. 100% AtmoSAFE.

From very small to very large! 32 litres or 1060 litres chamber volume? Standard applications or high demand for functionality, programming and documentation? In any case, all Memmert heating and drying ovens feature user-friendliness and state-of-the-art communication interfaces as a basic. Each individual appliance complies with the strict requirements of DIN 12880:2007-05 and is equipped with a maximum of safety functions. Each individual Memmert heating and drying oven is 100% AtmoSAFE.



UNIVERSAL OVEN U

PAGE 4 TO 5

TECHNICAL DATA

PAGE 6 TO 7

Drying, burning-in, ageing, vulcanising, degassing, curing, burn-in testing, conditioning, heated storage

PASS-THROUGH OVEN UF TS

PAGE 8 TO 9

TECHNICAL DATA

PAGE 10 TO 11

In-line curing and tempering

PARAFFIN OVEN UNpa

PAGE 12 TO 13

TECHNICAL DATA

PAGE 14 TO 15

Tempering of embedding media like paraffin and wax

STERILISER S

PAGE 16 TO 17

TECHNICAL DATA

PAGE 18 TO 19

Sterilising of instruments and laboratory glass

VACUUM OVEN VO

PAGE 20 TO 21

TECHNICAL DATA

PAGE 22 TO 23

Drying, burning-in, ageing, curing, degassing, conditioning, oxygen-free storing

COOLED VACUUM OVEN VOcool

PAGE 24 TO 25

TECHNICAL DATA

PAGE 26 TO 27

Drying, burning-in, ageing, curing, degassing, conditioning, oxygen-free storing

SOFTWARE FOR MODELS

U, UF TS, UNpa, S, I, ICO, ICP, IPP, IPS, HPP, ICH PAGE 28

AtmoCONTROL

OPTIONS AND ACCESSORIES

PAGE 28 TO 30

Available for all products

FEATURES OF MODEL VARIANTS

PAGE 31

SingleDISPLAY and TwinDISPLAY



Universal Oven UN and UF with SingleDISPLAY
Universal Oven UNplus and UFplus with TwinDISPLAY
Natural convection or forced ventilation
AtmoCONTROL software

Model sizes:

30 / 55 / 75 / 110 / 160 / 260 / 450 / 750 / 1060
+30 °C up to +300 °C

UNIVERSAL OVEN U The all-round genius among the heating ovens covers a multitude of applications, ideally at temperatures above +50 °C. Without compromises! Thanks to two model variants and nine sizes, optionally with natural or forced convection, industry, science and research institutes will find a heating and drying oven which combines top precision and safety with optimal operating comfort.

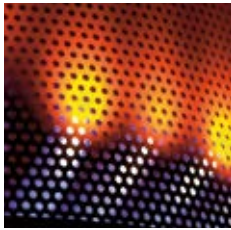

Defined and programme-controlled fan speed

Air exchange rates and air flap position can be controlled electronically at the ControlCOCKPIT. More inlet and outlet openings lead to a higher air exchange and reduced drying times. Various applications recommend or even require controlled ventilation. When drying powder, sand or corn, reducing the ventilation prevents undesired swirls.

Other applications like testing of wires or cables demand for defined air exchange rates. UFplus appliances feature easy programming of temperature and air exchange rates with the AtmoCONTROL software.

Fresh air is preheated

Temperature deviations caused by fresh air can influence sample characteristics or prolong drying. In Memmert universal ovens, the fresh air is therefore fed through a pre-heating chamber and introduced into the working chamber.

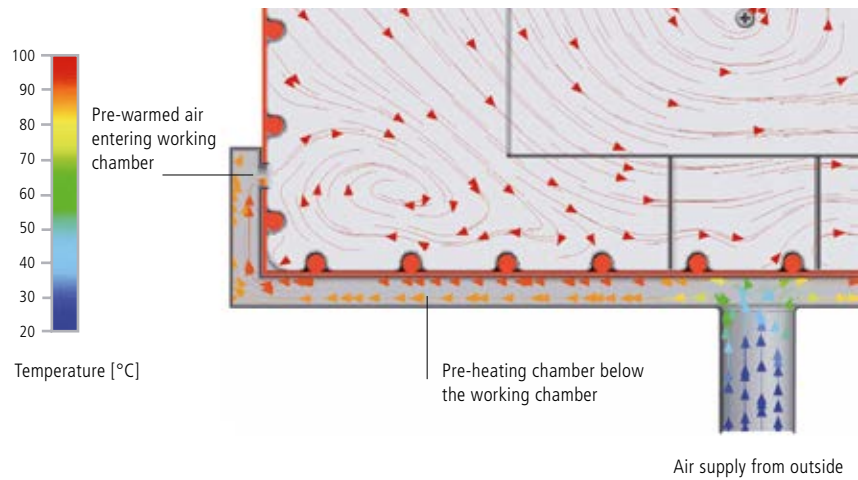

Intended purpose as a medical device:

Heating ovens UF (with extended overtemperature protection – option A6) and UFplus are applied for heating of non-sterile fabrics and covers.

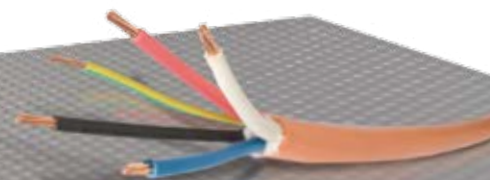

UNIVERSAL OVENS U

according to DIN 12880:2007-05, EN 61010-1 (IEC 61010-1), 61010-2-010
 Standard units are safety-approved and bear the test marks:



Standard equipment

- Interior:** Stainless steel, material 1.4301 (ASTM 304), with all-round deep-drawn ribs to integrate the large-area heating with ceramic-metal sheath
- Internals:** Stainless steel grids (sizes 30, 55 and 1060: 1 grid, sizes 75 – 750: 2 grids)
- Housing:** Textured stainless steel, rear zinc-plated steel, intuitively operated SingleDISPLAY or TwinDISPLAY (TFT colour display) with touchscreen (from size 450 two leaves)
- Fresh air:** Admixture of pre-heated fresh air by electronically adjustable air flap
- Connection:** Mains cable with plug (German type) CEE plug for 400 V
- Installation:** 4 feet; sizes 450, 750 and 1060 mounted on lockable castors

- Interfaces:**
- Ethernet LAN
 - USB (only TwinDISPLAY)

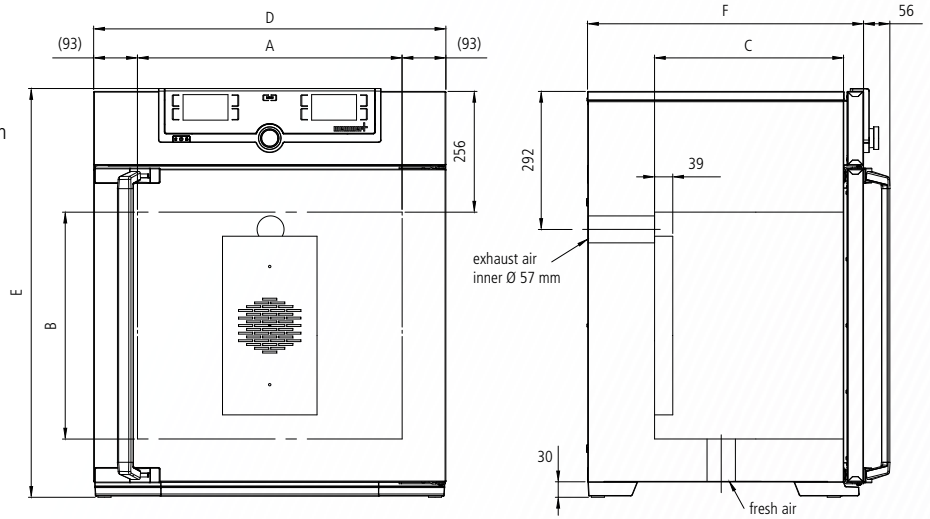

Model sizes/Description			30	55	75	110	160	260	450	750	1060	
Stainless steel interior	Volume	approx. l	32	53	74	108	161	256	449	749	1060	
	Width	(A) mm	400	400	400	560	560	640	1040	1040	1040	
	Height	(B) mm	320	400	560	480	720	800	720	1200	1200	
	Depth (less 39 mm for fan)	(C) mm	250	330	330	400	400	500	600	600	850	
	Stainless steel grids (standard equipment)	number	1			2					1	
	Max. number of grids/shelves	number	3	4	6	5	8	9	8	14	14	
	Max. loading per grid/shelf	kg	20							30		60
Max. loading of chamber	kg	60	80	120	175	210	300					
Textured stainless steel exterior	Width	(D) mm	585	585	585	745	745	824	1224	1224	1224	
	Height (size 450, 750, 1060 with castors)	(E) mm	704	784	944	864	1104	1183	1247	1726	1726	
	Depth (without door handle), door handle + 56 mm	(F) mm	434	514	514	584	584	684	784	784	1035	
Further data	Electrical load at 230 V, 50/60 Hz	approx. W	1600	2000	2500	2800	3200	3400	-			
	Electrical load at 115 V, 50/60 Hz	approx. W	1600	1700	1800					-		
	Electrical load at 400 V and 3 x 230 V w/o neutral, 50/60 Hz	approx. W	-						5800	7000		
	Working-temperature range	°C	at least 5 (UN/UNplus) at least 10 (UF/UFplus) above ambient temperature to +300									
	Setting temperature range	°C	+20 to +300									
	Setting accuracy	°C	up to 99.9: 0.1 / from 100: 0.5									
Packing data	Net weight	approx. kg	45	57	66	74	96	110	161	217	252	
	Gross weight (packed in carton)	approx. kg	61	76	85	99	122	161	227	288	416	
	Width	approx. cm	66	73	73	83	83	93	133	133	137	
	Height	approx. cm	89	95	113	105	130	138	144	191	197	
	Depth	approx. cm	65	67	67	80	80	93	105	105	130	
Order No. Universal Ovens U = Universal Oven N = Natural convection F = Forced air circulation plus = Model with TwinDISPLAY			UN30	UN55	UN75	UN110	UN160	UN260	UN450	UN750	-	
			UN30plus	UN55plus	UN75plus	UN110plus	UN160plus	UN260plus	UN450plus	UN750plus	-	
			UF30	UF55	UF75	UF110	UF160	UF260	UF450	UF750	UF1060	
			UF30plus	UF55plus	UF75plus	UF110plus	UF160plus	UF260plus	UF450plus	UF750plus	UF1060plus	

Options	30	55	75	110	160	260	450	750	1060	
Voltage 115 V, 50/60 Hz	X2						–			
Extended overtemperature protection by additionally integrated Pt100 sensor for independent temperature monitoring for models UN/UF						A6				
Full-sight glass door (4-layer insulating glass) – temperature-range up to max. 250 °C						B0				
Chamber modification for the application of reinforced perforated stainless steel shelves or stainless steel grids (bearing rails mounted in the working chamber) – includes replacement of 2 standard grids by 2 reinforced grids						–	K1	–		
Fresh-air filter (filtration efficiency 80 %) mounted at the bottom (for UF/UFplus) (for sizes 30 – 260 castor frame or subframe necessary – see page 29)						R8				
Interior lighting for observing the load						R0				
Interior socket (can only be ordered with limited temperature-range – max. +70 °C) current carrying ampacity 230 V, 2.2 A can be switched off with the On/Off switch, cannot be switched individually (option A8 necessary – see page 28)						R3				
Interior nearly gastight						K2				
Ditto, with possibility for gas inlet/outlet through 2 tubes with ball valves						K3				
Entry port, 23 mm clear diameter, for introducing connections at the side, can be closed by flap, standard positions						F0 F1 F2 F3				
Entry port, 23 mm clear diameter, for introducing connections, can be closed by flap in special positions (please, state location)						F4 F5 F6				
Entry port, 14 mm clear diameter, can be closed by flap, in special positions at the back (please, state location)						D6				
Entry port, 38 mm clear diameter, can be closed by flap, in special positions at the back (please, state location)						F7				
Entry port, 57 mm clear diameter, can be closed by flap, in special positions at the back (please, state location)						F8				
Entry port, 100 mm clear diameter, can be closed by flap, in special positions at the back (please, state location)						F9				
4 – 20 mA current loop interface (0 to +310 °C \pm 4 – 20 mA) Temperature of a Pt100 sensor positioned flexibly in chamber for external temperature monitoring (max. 1 SingleDISPLAY, max. 3 TwinDISPLAY)						V3 V6				
Fan speed monitoring with switching off the heating and with alarm in case of failure – optional for UFplus only						V4				
Works calibration certificate for 3 temperatures: +100 °C, +160 °C, +220 °C Standard works calibration certificate (measuring point chamber centre) at +160 °C						D00128				

Accessories	30	55	75	110	160	260	450	750	1060
Stainless steel grid (standard equipment)	E28884	E20164		E20165	E28891	E20182	B32550		
Additional reinforced stainless steel grid, max. loading 60 kg; from size 450 with guide bars and fixing screws (only in connection with option K1). Please consider max. loading of chamber		–		E29767	E29766	B32190	–		
Perforated stainless steel shelf	B29727	B03916		B00325	B29725	B00328	B32549		
Additional reinforced stainless steel shelf, max. loading 60 kg; with guide bars and fixing screws (only in connection with option K1). Please consider max. loading of chamber			–			B32191	–		
Stainless steel slide-in drip tray, 15 mm rim (may affect the temperature distribution) – cannot be used in connection with option K1	E02070	E02072		E02073	E29726	E02075	B32599		
Max. loading per slide-in drip tray (kg)		1.5		3	4	8			
Stainless steel slide-in drip tray, 15 mm rim, with guide bars and fixing screws (can be used only in connection with option K1)			–			B32763	–		
Stainless steel bottom drip tray, 15 mm rim (may affect the temperature distribution) – cannot be used in connection with option K1	B04356	B04358		B04359	B29722	B04362	B29769		
Max. loading per bottom drip tray (kg)		1.5		3	4	8			
Stainless steel bottom drip tray, 15 mm rim (can be used only in connection with option K1)			–			B34055	–		
Wall bracket for wall mounting	B29755	B29756	B29757	B29758	B29759	–			
Guarantee extension by 1 year		GA1Q5					GA2Q5		



Pass-through oven UF TS
TwinDISPLAY
Forced convection
AtmoSAFE standard software

Model sizes:
160 / 260 / 450 / 750
+30 °C to +300 °C

PASS-THROUGH OVEN UF TS Pass-through ovens UF TS are based on a standard heating oven and feature all technological highlights like product specific heating and perfectly adjusted control technology. Thanks to an additional side feed-through, curing of lead frames and adhesive bonds or tempering of components can be controlled automatically within a running production process.

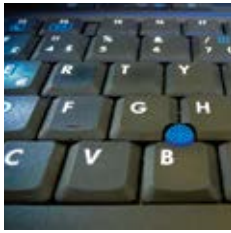

High feed-through thanks to in-line capability

Temperature control processes in a Memmert pass-through oven can be controlled fully electronically. The synchronised loading of parts is done by means of belt input and output at the side. To increase the feed-through for endless loading, turn pulleys can be installed in the chamber on request. Windows at the front and rear enable simple loading by hand, and also allow the temperature control process to be permanently observed. Another advantage not to be missed out: constant temperatures inside the temperature-control chamber as it does not have to be opened for loading.



In-line capable
pass-through oven
(belt input and output
at the side)



Customer-specific solutions myAtmoSAFE

In the position of an expansion of the R&D departments of customers, the customisation department at Memmert provides support for complex applications and finds tailor-made solutions. Many customers are supported from development to production.



PASS-THROUGH OVENS UF TS

according to DIN 12880:2007-05



Standard equipment

Interior:	Stainless steel, mat. 1.4301 (ASTM 304), with all-round deep-drawn ribs to integrate the large-area heating with ceramic-metal sheath
Internals:	2 stainless steel grids
Housing:	Textured stainless steel, intuitively operated TwinDISPLAY (TFT colour displays) with touchscreen, fully insulated stainless steel door on both sides (from model size 450 two leaves), pass-through version
Fresh air:	Admixture of pre-heated fresh air by electronically adjustable air flap
Connection:	Mains cable with plug (German type) (CEE plug for 400 V)
Installation:	4 feet

Interfaces:

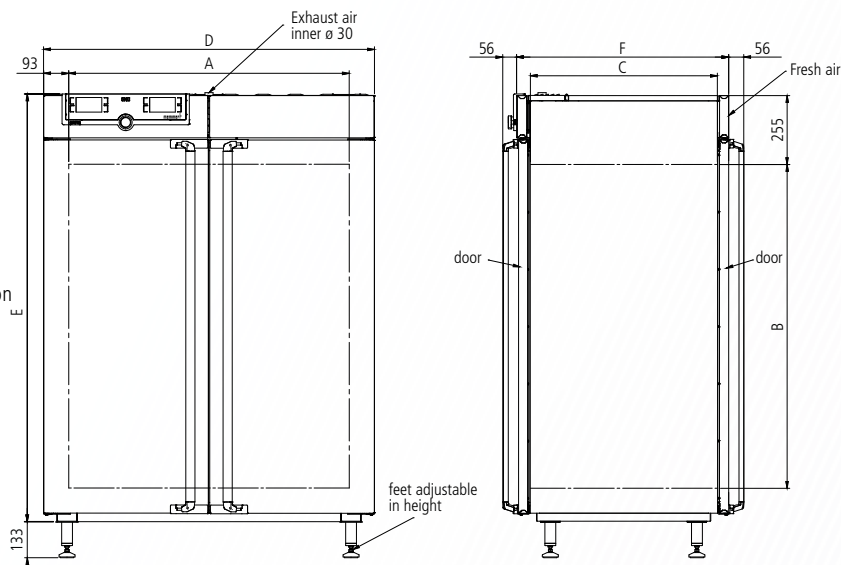

Model sizes/Description			160	260	450	750
Stainless steel interior	Volume	approx. l	161	256	449	749
	Width	(A) mm	560	640	1040	1040
	Height	(B) mm	720	800	720	1200
	Depth	(C) mm	400	500	600	600
	Stainless steel grids (standard equipment)	number	2			
	Max. number of grids/shelves	number	8	9	8	14
	Max. loading per grid/shelf	kg	20		30	
Max. loading of chamber	kg	210	300			
Textured stainless steel exterior	Width	(D) mm	745	824	1224	1224
	Height	(E) mm	1104	1183	1247	1726
	Depth (without door handle, depth of handle 2 x 56 mm)	(F) mm	584	684	784	784
Further data	Electrical load at 230 V, 50/60 Hz	approx. W	3200	3400	–	
	Electrical load at 115 V, 50/60 Hz	approx. W	1800		–	
	Electrical load at 400 V and 3 x 230 V w/o neutral, 50/60 Hz	approx. W	–		5800	7000
	Working-temperature range	°C	at least 10 above ambient temperature to +300			
	Setting temperature range	°C	+20 to +300			
	Setting accuracy	°C	up to 99.9: 0.1 / from 100: 0.5			
Packing data	Net weight	approx. kg	120	138	213	260
	Gross weight (packed in carton)	approx. kg	146	189	279	331
	Width	approx. cm	83	93	133	133
	Height	approx. cm	130	138	145	192
	Depth	approx. cm	80	93	105	105

Order No. Pass-Through Ovens

UF160TS UF260TS UF450TS UF750TS

Optionen	160	260	450	750
Voltage 115 V, 50/60 Hz	X2		–	
Extended overtemperature protection by additionally integrated Pt100 sensor for independent temperature monitoring			A6	
Full-sight glass door (4-layer insulating glass) – per side – temperature-range up to max. 250 °C			B0	
Chamber modification for the application of reinforced perforated stainless steel shelves or stainless steel grids (bearing rails mounted in the working chamber) – includes replacement of 2 standard grids by 2 reinforced grids			K1	
Entry port, 23 mm clear diameter, for introducing connections at the side, can be closed by flap, standard positions	left centre/centre left centre top right centre/centre right centre top			F0 F1 F2 F3
Entry port, 23 mm clear diameter for introducing connections at the side, can be closed by flap, in special positions (please, state location)	left right			F4 F5
Process-dependent electromagnetic door lock (both sides)			D4	
Locking mechanism to prevent simultaneous opening of doors for contamination protection in case of wall installation			D5	
4 – 20 mA current loop interface (0 to +310 °C \pm 4 – 20 mA)			V3 V6	
Temperature controller actual value Temperature of a Pt100 sensor positioned flexibly in chamber for external temperature monitoring (max. 1 SingleDISPLAY, max. 3 TwinDISPLAY) – price per sensor				
Fan speed monitoring with switching off the heating and with alarm in case of failure			V4	
Works calibration certificate for 3 temperatures: +100 °C, +160 °C, +220 °C Standard works calibration certificate (measuring point chamber centre) at +160 °C			D00128	

Accessories	160	260	450	750
Stainless steel grid (standard equipment)	E20165	E28891	E20182	
Additional reinforced stainless steel grid, max. loading 60 kg; with guide bars and fixing screws (only in connection with option K1). Please consider max. loading of chamber	–		B32190	
Perforated stainless steel shelf	B00325	B29725	B00328	
Additional reinforced perforated stainless steel shelf, max. loading 60 kg; with guide bars and fixing screws (only in connection with option K1). Please consider max. loading of chamber	–		B32191	
Stainless steel slide-in drip tray, 15 mm rim (may affect the temperature distribution) – cannot be used in connection with option K1	E02073	E29726	E02075	
Max. loading per slide-in drip tray (kg)	3	4	8	
Stainless steel slide-in drip tray, 15 mm rim, with guide bars and fixing screws (can be used only in connection with option K1)	–		B32763	
Stainless steel bottom drip tray, 15 mm rim (may affect the temperature distribution) – cannot be used in connection with option K1	B04359	B29722	B04362	
Max. loading per bottom drip tray (kg)	3	4	8	
Stainless steel bottom drip tray, 15 mm rim (can be used only in connection with option K1)	–		B34055	
Flush-fit unit set (stainless steel frame covering gap between oven and wall opening), without air slots – technical clarification required	B33204	B33205	B33206	B33207
Guarantee extension by 1 year	GA1Q5	GA2Q5		



Paraffin oven UNpa with TwinDISPLAY
AtmoCONTROL software

Model sizes:
30 / 55 / 75 / 110 / 160
+30 °C to +80 °C

PARAFFIN OVEN UNpa Five model sizes, five times high-precision temperature control of the embedding medium paraffin in science and research. The range of functions and thermal safety of paraffin ovens UNpa are designed specifically for absolutely reliable sample preparation in the laboratory. The benefits for the user: an optimal cost/benefit ratio for an appliance that guarantees, for many years, precise and even temperature control for embedding media without any loss in quality whatsoever.



Safe warming of paraffin

Thanks to its high capillarity, liquid paraffin is an ideal embedding medium. This property, however, may lead to oily residue in tiny cavities. For this reason, the interior chamber of paraffin ovens UNpa is designed almost gas tight. There is definitely no danger of ignition of residue or damage to mechanical and electronic components.

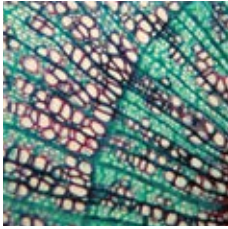

Absolutely uniform temperature distribution

Due to the almost gas tight chamber, no outside air is exchanged. Therefore, the advantages of the uniform temperature distribution by the large surface all-round heating system applied in Memmert heating ovens come fully into play. Also without forced convection, the perfect interaction of the control system and heating unit ensures unparalleled temperature homogeneity and stability.

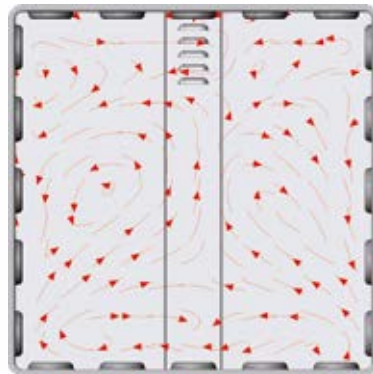

Air flow with
natural convection



PARAFFIN OVENS UNpa

according to DIN 12880:2007-05, EN 61010-1 (IEC 61010-1), 61010-2-010



Standard equipment

Interior: Stainless steel, material 1.4301 (ASTM 304), with all-round deep-drawn ribs to integrate the large-area heating with ceramic-metal sheath

Internals: Stainless steel grids (sizes 30 and 55: 1 grid, sizes 75 – 160: 2 grids)

Housing: Textured stainless steel, rear zinc-plated steel, intuitively operated TwinDISPLAY (TFT colour display) with touchscreen, fully insulated stainless steel door

Connection: Mains cable with plug (German type)

Installation: 4 feet

Interfaces:

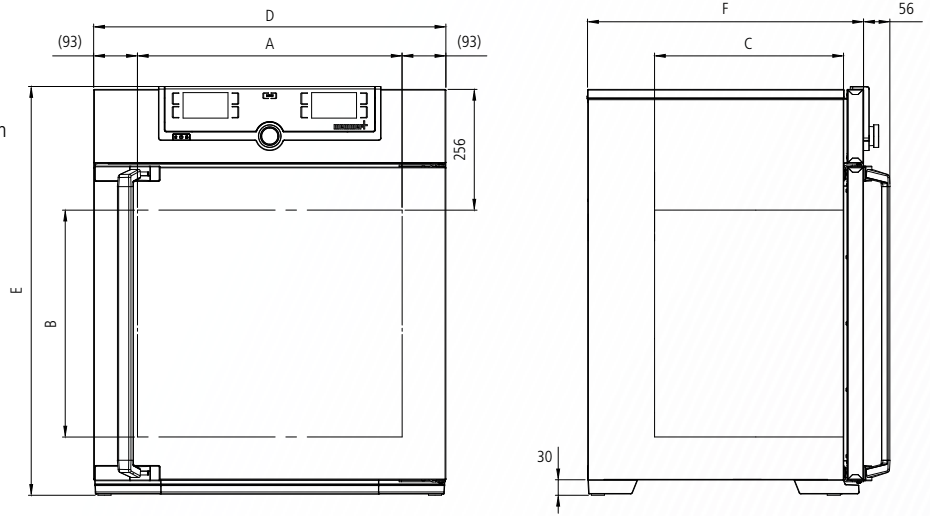
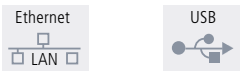

Model sizes/Description			30	55	75	110	160
Stainless steel interior	Volume	approx. l	32	53	74	108	161
	Width	(A) mm	400	400	400	560	560
	Height	(B) mm	320	400	560	480	720
	Depth	(C) mm	250	330	330	400	400
	Stainless steel grids (standard equipment)	number	1		2		
	Max. number of grids/shelves	number	3	4	6	5	8
	Max. loading per grid/shelf	kg	20				
	Max. loading of chamber	kg	60	80	120	175	210
Textured stainless steel exterior	Width	(D) mm	585	585	585	745	745
	Height	(E) mm	704	784	944	864	1104
	Depth (without door handle), door handle + 56 mm	(F) mm	434	514	514	584	584
Further data	Electrical load at 230 V, 50/60 Hz	approx. W	1600	2000	2500	2800	3200
	Electrical load at 115 V, 50/60 Hz	approx. W	1600	1700	1800		
	Working-temperature range	°C	at least 5 above ambient temperature to +80				
	Setting temperature range	°C	+20 to +80				
	Setting accuracy	°C	0.1				
Packing data	Net weight	approx. kg	45	55	66	75	96
	Gross weight (packed in carton)	approx. kg	61	74	85	100	122
	Width	approx. cm	66	73	73	83	83
	Height	approx. cm	89	95	113	105	130
	Depth	approx. cm	65	67	67	80	80
Order No. Paraffin Ovens			UN30pa	UN55pa	UN75pa	UN110pa	UN160pa

Options	30	55	75	110	160
Voltage 115 V, 50/60 Hz			X2		
Full-sight glass door (4-layer insulating glass)			B0		
Entry port, 23 mm clear diameter, for introducing connections at the side, gas tight, can be closed by flap and silicone stopper, standard positions			left centre/centre left centre top right centre/centre right centre top	F0 F1 F2 F3	
Entry port, 23 mm clear diameter, for introducing connections, gas tight, can be closed by flap and silicone stopper, in special positions (please, state location)			left right rear	F4 F5 F6	
Entry port, 40 mm clear diameter, for introducing connections, gas tight, can be closed by flap and silicone stopper, in special positions at the back (please, state location)				F7	
4 – 20 mA current loop interface (0 to +90 °C \pm 4 – 20 mA)				V3	
Temperature of a Pt100 sensor positioned flexibly in chamber for external temperature monitoring (max. 3 TwinDISPLAY)				V6	
Gas inlet and outlet through 2 tubes with ball valves				K3	
Works calibration certificate for 3 temperatures: +37 °C, +52 °C, +70 °C Standard works calibration certificate (measuring point chamber centre) at +80 °C				D00126	

Accessories	30	55	75	110	160
Stainless steel grid (standard equipment)	E28884	E20164		E20165	
Perforated stainless steel shelf	B29727	B03916		B00325	
Stainless steel slide-in drip tray, 15 mm rim (may affect the temperature distribution)	E02070	E02072		E02073	
Max. loading per slide-in drip tray (kg)		1.5		3	
Stainless steel bottom drip tray, 15 mm rim (may affect the temperature distribution)	B04356	B04358		B04359	
Max. loading per bottom drip tray (kg)		1.5		3	
Wall bracket for wall mounting	B29755	B29756	B29757	B29758	B29759
Guarantee extension by 1 year				GA1Q5	



Steriliser SN and SF with SingleDISPLAY
 Steriliser SNplus and SFplus with TwinDISPLAY
 Natural convection or forced ventilation
 AtmoCONTROL software

Model sizes:
 30 / 55 / 75 / 110 / 160 / 260 / 450 / 750
 +30 °C to +250 °C

STERILISER S Medicine has the goal of protecting and saving lives. Therefore, disinfection of receptacles and instruments is not enough. The setpoint-dependent programme resume function SetpointWAIT of Memmert hot air sterilisers guarantees precise sterilisation times and the complete killing off of even the most resistant microorganisms. The classification as class IIa medical device confirms that all Memmert sterilisers comply with the basic safety requirements of the European Medical Devices Directive 93/42/EEC.



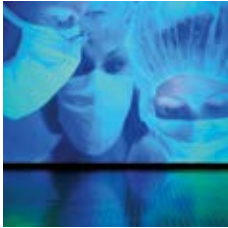

SetpointWAIT function

Exactly timed temperature control helps to save lives when it comes to sterilisation of instruments and laboratory equipment. Therefore, the SetpointWAIT function guarantees that the sterilisation time does not start before the compensation time is reached. When measuring with additional freely positionable Pt100 sensors (optional), reaching the set temperature at all measuring points on the chamber load is decisive for the continuation of the programme. Up to three measurements can be displayed directly on the ControlCOCKPIT or one measurement on an external measuring device or a 4 – 20 mA interface.

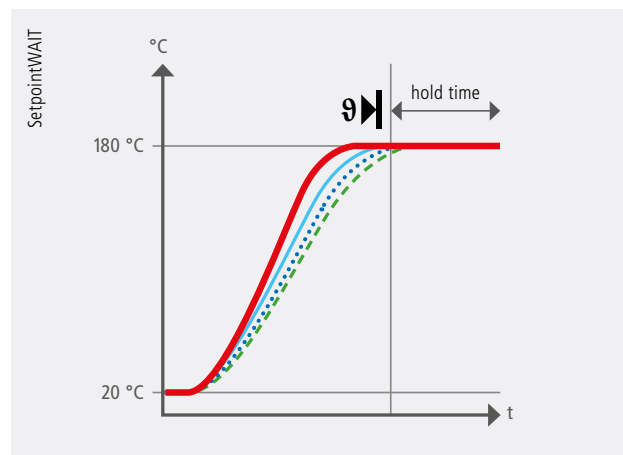

When the SetpointWAIT function is activated, the hold time does not start until the temperature within a very narrow tolerance range is reached at all measuring points

—
Temperature of the Pt100 sensor inside the chamber

Temperature of the flexible Pt100 sensors inside the chamber

Validation without problems

Particularly thanks to the SetpointWAIT function, Memmert hot air sterilisers comply with all strict requirements on quality assurance and can therefore be validated without problems. Besides the possibility to measure the temperature directly at the load inside the chamber (optional), the appliances completely document the entire process. In combination with the User-ID-Key for TwinDISPLAY appliances, the process-controlled door locking mechanism (optional) is the icing on the cake in terms of safety.



Intended purpose as a medical device:

Hot air sterilisers SN/SF and SNplus/SFplus are applied for sterilisation of medical materials. All Memmert sterilisers are classified as class IIb medical device. They are also suited without restriction for the special application of depyrogenisation with hot air.

STERILISERS S

according to DIN 12880:2007-05, EN 61010-1 (IEC 61010-1), 61010-2-010 and 61010-2-40

Standard units are safety-approved and bear the test marks:



Standard equipment

Interior: Stainless steel, material 1.4301 (ASTM 304), with all-round deep-drawn ribs to integrate the large-area heating with ceramic-metal sheath

Internals: Stainless steel grids (sizes 30 and 55: 1 grid, sizes 75 – 750: 2 grids)

Housing: Textured stainless steel, rear zinc-plated steel, intuitively operated SingleDISPLAY or TwinDISPLAY (TFT colour display) with touchscreen (from size 450 two leaves)

Fresh air: Admixture of pre-heated fresh air by electronically adjustable air flap

Connection: Mains cable with plug (German type) CEE plug for 400 V

Installation: 4 feet; sizes 450 and 750 mounted on lockable castors

Interfaces: Ethernet LAN and USB (only TwinDISPLAY)

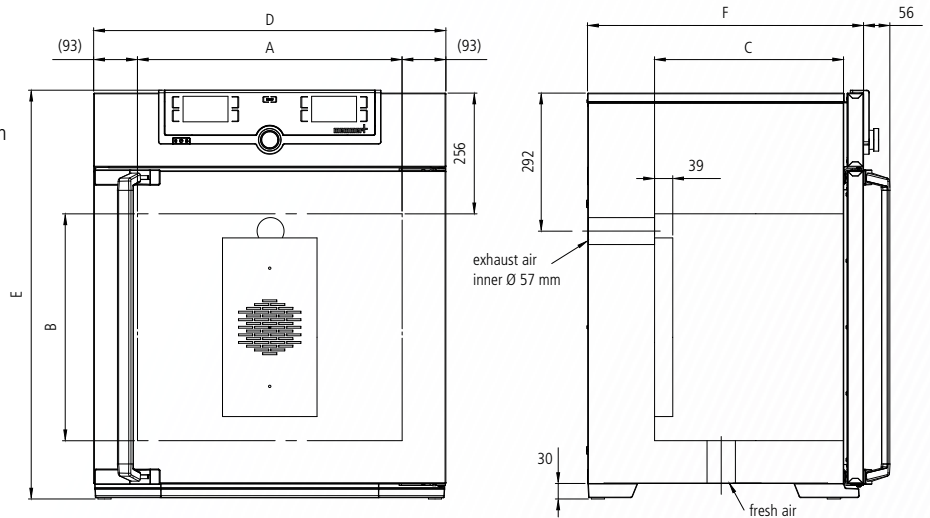

Model sizes/Description			30	55	75	110	160	260	450	750	
Stainless steel interior	Volume	approx. l	32	53	74	108	161	256	449	749	
	Width	(A) mm	400	400	400	560	560	640	1040	1040	
	Height	(B) mm	320	400	560	480	720	800	720	1200	
	Depth (less max. 39 mm for fan)	(C) mm	250	330	330	400	400	500	600	600	
	Stainless steel grids (standard equipment)	number	1			2					
	Max. number of grids/shelves	number	3	4	6	5	8	9	8	14	
	Max. loading per grid/shelf	kg	20							30	
Max. loading of chamber	kg	60	80	120	175	210	300				
Textured stainless steel exterior	Width	(D) mm	585	585	585	745	745	824	1224	1224	
	Height (size 450, 750 with castors)	(E) mm	704	784	944	864	1104	1183	1247	1726	
	Depth (without door handle), door handle + 56 mm	(F) mm	434	514	514	584	584	684	784	784	
Further data	Electrical load at 230 V, 50/60 Hz	approx. W	1600	2000	2500	2800	3200	3400	–		
	Electrical load at 115 V, 50/60 Hz	approx. W	1600	1700	1800					–	
	Electrical load at 400 V and 3 x 230 V w/o neutral, 50/60 Hz	approx. W	–							5800	7000
	Working-temperature range	°C	at least 5 (SN/SNplus) 10 (SF/SFplus) above ambient temperature to +250								
	Setting temperature range	°C	+20 to +250								
Setting accuracy	°C	up to 99.9: 0.1 / from 100: 0.5									
Packing data	Net weight	approx. kg	46	57	66	74	96	110	161	217	
	Gross weight (packed in carton)	approx. kg	62	76	85	99	122	161	227	288	
	Width	approx. cm	66	73	73	83	83	93	133	133	
	Height	approx. cm	89	95	113	105	130	138	144	191	
	Depth	approx. cm	65	67	67	80	80	93	105	105	
Order No. Sterilisers			SN30	SN55	SN75	SN110	SN160	SN260	SN450	SN750	
S = Steriliser			SN30plus	SN55plus	SN75plus	SN110plus	SN160plus	SN260plus	SN450plus	SN750plus	
N = Natural convection			SF30	SF55	SF75	SF110	SF160	SF260	SF450	SF750	
F = Forced air circulation			SF30plus	SF55plus	SF75plus	SF110plus	SF160plus	SF260plus	SF450plus	SF750plus	
plus = Model with TwinDISPLAY											

Options	30	55	75	110	160	260	450	750	
Voltage 115 V, 50/60 Hz	X2						–		
Extended overtemperature protection by additionally integrated Pt100 sensor for independent temperature monitoring for models SN/SF							A6		
Full-sight glass door (4-layer insulating glass)							B0		
Interior lighting for observing the load							R0		
Chamber modification for the application of reinforced perforated stainless steel shelves or stainless steel grids (bearing rails mounted in the working chamber) – includes replacement of 2 standard grids by 2 reinforced grids	–						K1		
Fresh-air filter (filtration efficiency 80 %) mounted at the appliance bottom (for SF/SFplus) (for sizes 30 – 260 castor frame or subframe necessary – see page 29)							R8		
Entry port, 23 mm clear diameter, for introducing connections at the side, can be closed by flap, standard positions	left centre/centre left centre top right centre/centre right centre top			F0 F1 F2 F3					
Entry port, 23 mm clear diameter, for introducing connections, can be closed by flap in special positions (please, state location)	left right rear			F4 F5 F6					
Entry port, 14 mm clear diameter, can be closed by flap, in special positions at the back (please, state location)							D6		
Entry port, 38 mm clear diameter, can be closed by flap, in special positions at the back (please, state location)							F7		
4 – 20 mA current loop interface (0 to +310 °C \pm 4 – 20 mA) Temperature of a Pt100 sensor positioned flexibly in chamber for external temperature monitoring (max. 1 SingleDISPLAY, max. 3 TwinDISPLAY)							V3 V6		
Fan speed monitoring with switching off the heating and with alarm in case of failure optional for SFplus only							V4		
Works calibration certificate for 3 temperatures: +160 °C, +180 °C, +250 °C Standard works calibration certificate (measuring point chamber centre) at +160 °C							D00132		

Accessories	30	55	75	110	160	260	450	750
Stainless steel grid (standard equipment)	E28884	E20164		E20165		E28891	E20182	
Additional reinforced stainless steel grid, max. loading 60 kg; from size 450 with guide bars and fixing screws (only in connection with option K1). Please consider max. loading of chamber	–		E29767		E29766		B32190	
Perforated stainless steel shelf	B29727	B03916		B00325		B29725	B00328	
Additional reinforced stainless steel shelf, max. loading 60 kg; with guide bars and fixing screws (only in connection with option K1). Please consider max. loading of chamber	–						B32191	
Stainless steel slide-in drip tray, 15 mm rim (may affect the temperature distribution) – cannot be used in connection with option K1	E02070	E02072		E02073		E29726	E02075	
Max. loading per slide-in drip tray (kg)	1.5		3		4		8	
Stainless steel slide-in drip tray, 15 mm rim, with guide bars and fixing screws (can be used only in connection with option K1)	–						B32763	
Stainless steel bottom drip tray, 15 mm rim (may affect the temperature distribution) – cannot be used in connection with option K1	B04356	B04358		B04359		B29722	B04362	
Max. loading per bottom drip tray (kg)	1.5		3		4		8	
Stainless steel bottom drip tray, 15 mm rim (can be used only in connection with option K1)	–						B34055	
Wall bracket for wall mounting	B29755	B29756	B29757	B29758	B29759		–	
Guarantee extension by 1 year	GA1Q5						GA2Q5	



Vacuum oven VO
"Celsius" standard software

Model sizes:
200 / 400 / 500
+20 °C to +200 °C
5 mbar to 1100 mbar

VACUUM OVEN VO Memmert vacuum ovens show their full potential with short heating up times, high precision temperature control and turbo drying. At the same time, heat and oxygen sensible materials are treated with incomparable care. Memmert is the only manufacturer worldwide that offers digital pressure control. As addition to the vacuum oven, Memmert offers a special controllable pump for installation in a lower chamber, the pump module, installed on the outside of the vacuum oven.





Customised models for every application

As much function as needed, as much customisation as possible! The basic model of the vacuum oven features a thermoshelf, two thermoshelf connectors as well as an USB interface, "Celsius" software and MEMoryCARD. The vacuum oven can be customised with additional functions for individual applications.

- **OPTION INERT GAS INLET:** Programmable and digitally controlled inlet for inert gas with flow rate reduction
- **PREMIUM MODULE:** The option for switching to inert gas well as additional connection (VO200) or two further connections (VO400, VO500) for thermoshelves and one additional thermoshelf (for VO400, VO500), drip tray and interface for printer

Multi-Level-Heating

Each of the thermoshelves that can be inserted as required is equipped with separate large surface heating and its own sensors (Multi-Level-Sensing MLS). The separate control circuits react precisely to different loads and humidity values and maintain the pre-set temperature equally on all the levels used. Due to the direct contact between the heating system and the chamber load, there is practically no loss of heat and heating and process times are reduced by some 75 % compared to a conventional heating system of the interior walls.

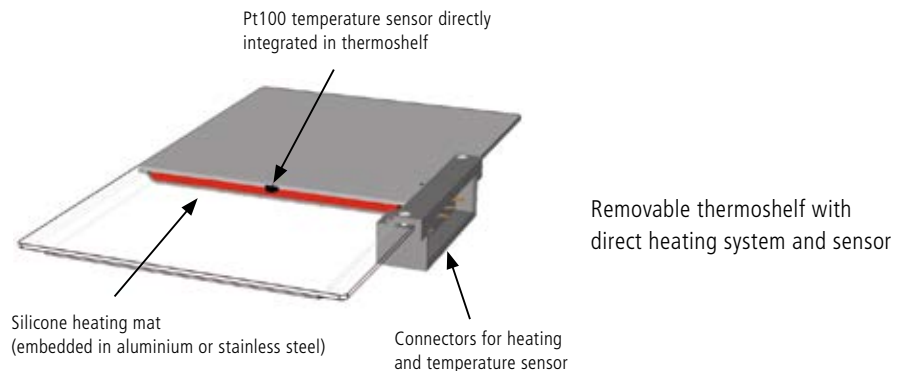

Repeat function with turbo effect

User-friendly ramp programming saves effort and guarantees reliable processes. Thanks to programming of vacuum cycles, the drying time can be considerably further reduced. Up to 40 ramps with different set temperature and vacuum values can be directly programmed on the device or via the MEMoryCard. When using the "Celsius" software, the number of ramps is practically unlimited.

VACUUM OVENS VO

according to DIN 12880:2007-05, EN 61010-1 (IEC 61010-1)

Standard units are safety-approved and bear the test marks:



Standard equipment

- Interior:** Stainless steel interior, material 1.4404 (ASTM 316 L), hermetically welded, with removable mountings at the sides for cleaning, including thermoshelf guide bars, as well as mounting on top to avoid turbulences
- Internals:** Thermoshelf, aluminium, eloxadised material 3.3547 (ASTM B209)
- Housing:** Textured stainless steel, rear zinc-plated steel, aesthetic functional glass-stainless steel operating panel with multifunction display and input module, safety glass door with inner bullet-proof glass and external anti-splinter screen
- Installation:** 4 feet
- Connection:** Mains cable with plug (German type)
- Interfaces:**



Optional:

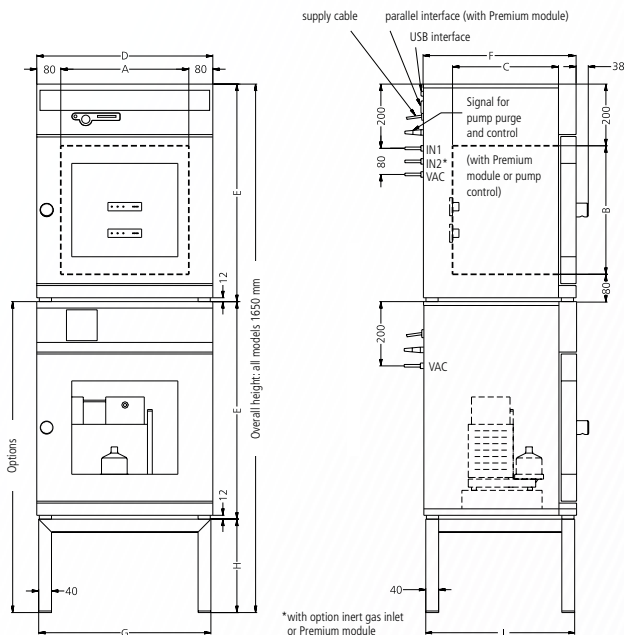

*with option inert gas inlet or Premium module

Model sizes/Description		200	400	500	
Stainless steel interior	Volume	approx. l	29	49	101
	Width (A)	mm	385	385	545
	Height (B)	mm	305	385	465
	Depth (C)	mm	250	330	400
	Max. number of thermoshelves – basic equipment/with Premium Module	number	2/3	2/4	
	Distance between thermoshelves	mm	75		95
	Maximum load per shelf	approx. kg	20		
	Maximum load per oven	approx. kg	40	60	
Textured stainless steel housing <small>The dimensions also apply to the optional pump module</small>	Width (D)	mm	550	550	710
	Height (E)	mm	600	680	760
	Depth (without door handle, depth of handle 38 mm) (F)	mm	400	480	550
	Safety glass door: Textured stainless steel frame with spring-loaded safety glass on inside and anti-splinter screen ESG on outside of door			☐	
Door seal	Endless silicone profile seal		☐		
Temperature	Electronic microprocessor temperature controller with Pt100 and auto-diagnostic system		☐		
	Temperature sensor Pt100 Class A in 4-wire circuit individually for each thermoshelf		☐		
	Working-temperature range	°C	at least 5 above ambient temperature to +200		
	Setting temperature range	°C	+20 to +200		
	Temperature variation in time (to DIN 12880:2007-05) (aluminium thermoshelf)	K	≤ ± 0.3		
	Temperature uniformity (surface) at +160 °C/20 mbar (aluminium thermoshelf)	K	≤ ± 2		
Pressure (vacuum)	Digital electronic pressure control (in programme operation up to 40 ramps, adjustable for each segment) for vacuum via solenoid valves. Tubing for vacuum, air and inert gas are made of material 1.4571 (ASTM 316 Ti). Adjustable from 5 mbar up to 1100 mbar. Programmable, digitally controlled inlet for air. Integrated process control with programmable temperature and vacuum cycles enabling amongst others accelerated moisture reduction.		☐		
	Rapid air intake for door opening without alteration of selected vacuum setpoint		☐		
	Permitted final vacuum	mbar	0.01		
	Maximum leakage rate	bar/h	0.01		
Monitor	Microprocessor temperature monitor acting as overtemperature protection (protection class 3.1) with Pt100, incorporating fault diagnostics with visual and acoustic alarm		☐		
	Digital over- and undertemperature monitors		☐		
	Temperature monitoring band automatically linked to the setpoint (ASF)		☐		
	Multi-Level-Overtemperature-Protection (MLOP) for each thermoshelf		☐		
	Relay for reliable heating cut-off in case of fault		☐		

Model sizes/Description		200	400	500	
	Mechanical temperature limiter (TB)		□		
	Acoustic alarm: Over- and undertemperature		□		
Timer functions	Real-time/weekly programmer with group function (e.g. Monday – Friday)		□		
	Timer with residual running time: max. 40 ramps (each 1 min. up to 999 h) programmable through controller or MEMoryCard XL; programming via PC and free-of-charge software: unlimited number of ramps		□		
Documentation	Internal log memory 1024 kB as ring memory for all setpoints, actual values, errors, settings with real-time and date; capacity up to 3 months at 1 min. intervals		□		
	“Celsius” software for control and documentation of temperature and pressure		□		
Setup	Calibration (no sep. PC required), temperature and pressure: 3-point calibration on controller		□		
	Setting of language for dialogue and display DE / EN / ES / FR / IT		□		
Connections	Vacuum connection with small flange DN16, and gas inlet with small flange DN 16		□		
Further data	Electrical load (loading with max. number of thermoshelves), at 230 V, 50/60 Hz	approx. W	1200	2000	2400
Standard accessories	Pump control: optimised rinsing procedures for the pump membranes as well as signal output for pump ON/OFF		□		
	Removable interior mounting – stainless steel material 1.4404 (ASTM 316 L) – with integrated lateral guide bars for thermoshelves		□		
	Connectors for thermoshelves	number	2		
	Thermoshelves - aluminium eloxadised, mat. 3.3547 (ASTM B209) – with integrated large-area heating including local temperature sensing (Pt100, 4-wire-circuit); individual overtemp. protection for each shelf. Further data see stainless steel number inner working chamber	number	1		
	Works calibration certificate (measuring point in the middle of the individual shelf for +160 °C at 20 mbar pressure): a separate certificate is prepared for each thermoshelf ordered and shipped together with the vacuum oven		□		
Packing data / Vacuum oven	Net weight/Gross weight (packed in carton)	approx. kg	55/76	83/104	110/135
	Packed dimensions Width/Height/Depth	approx. cm	66/87/59	66/87/59	83/105/80
Packing data / Pump module	Net weight without/with pump	approx. kg	25/41	30/46	41/57
	Gross weight (packed in carton) without/with pump	approx. kg	46/62	51/67	66/82
	Packed dimensions Width/Height/Depth	approx. cm	66/87/59	66/87/59	83/105/80
Order No. Vacuum Ovens			VO200	VO400	VO500
Options		200	400	500	
Inert gas inlet: programmable and digitally controlled inlet for inert gas with flow rate reduction			W5		
Premium Module: comprises the inert gas inlet, one printer interface, extra connectors for thermoshelves, 1 (size 200), 2 (sizes 400/500), an additional thermoshelf (sizes 400/500) and a drip tray			T5		
Accessories		200	400	500	
Additional thermoshelf – aluminium eloxadised material W-St. 3.3547 (ASTM B209) with integrated large-area heating including local temperature sensing (Pt100, 4-wire-circuit); individual overtemp. protection for each shelf MLOP (Multi-Level-Overtemperature-Control) and calibration certificate			B00741	B00743	B00744
Additional thermoshelf – stainless steel material 1.4404 (ASTM 316 L) for especially corrosive material with integrated large-area heating including local temperature sensing (Pt100, 4-wire-circuit); individual overtemp. protection for each shelf MLOP (Multi-Level-Overtemperature-Control) and calibration certificate			B00733	B00734	B00735
Removable bottom drip tray – stainless steel material 1.4404 (ASTM 316 L)			E04256	E04257	E04258
Subframe, tubular steel, black enamelled (for stacking unit consisting of vacuum oven and pump module, total height: 1650 mm, see sketch of oven dimensions)		mm	E02030 529/450/ 383	E02031 529/290/ 463	E02037 689/130/ 533
Works calibration certificate for 3 temperatures: +50 °C, +100 °C, +160 °C at 20 mbar pressure					D00115
Guarantee extension by 1 year (VO only)					GA2Q5
Noise-insulated vacuum pump module without pump (exterior dimensions and material No. see vacuum oven) with antivibration metal plate at the bottom to accommodate the vacuum pump, incl. full-sight glass door. Socket, signal cable and connecting hose to the vacuum oven			PM200	PM400	PM500
Noise-insulated vacuum pump module, as above, however with built-in pump, 230 V, 50/60 Hz, (pump B04133 for VO200 and pump B04134 for VO400 and VO500)			PMP200	PMP400	PMP500
Signal cable (3 m) for optimising pump performance by demand-controlled activation of purge of Memmert pump					B04027
Vacuum connecting hose (3 m) from oven to Memmert pump incl. optimised connection accessories (partially stainless steel)					B04026
Chemically resistant vacuum pump with PTFE double diaphragm, pump capacity at atm. pressures: approx. 34 NL./min = 2,04 m³/h and autom. purge control from vacuum oven. Order No. B04027 and B04026 necessary. 230 V, 50 Hz. Max. guarantee period 2 years			B04133		–
Chemically resistant vacuum pump with PTFE double diaphragm, pump capacity at atm. pressures: approx. 60 NL./min = 3,6 m³/h and autom. purge control from vacuum oven. Order No. B04027 and B04026 necessary. 230 V, 50/60 Hz. Max. guarantee period 2 years			–		B04134



Cooled vacuum oven VOcool
"Celsius" standard software

Model sizes:
200 / 400
+5 °C to +90 °C
5 mbar to 1100 mbar

COOLED VACUUM OVEN VOcool Freeze-drying, the most common means of drying starter cultures and probiotics is very energy-intensive. Furthermore, some bacterial strains do not survive the freezing process. Thanks to low temperature vacuum drying, unstable substances can be dried at moderate temperatures above zero without causing too much damage to the cell structure. Memmert is the first manufacturer worldwide that has developed a cooled vacuum oven for laboratory application.





Fields of application

Thanks to low temperature vacuum drying in VOcool appliances, bacteria and starter cultures in the pharmaceutical and food industry can be gently dried. Additionally, the appliance offers the possibility to simulate programme-controlled transport and storage scenarios to determine the behaviour of active ingredients or volumes under different pressure and temperature conditions.



Unparalleled precision

The compact, energy-saving and extremely accurate Peltier-cooling unit guarantees a surface temperature distribution with a maximum deviation of ± 1 K across the entire temperature range. Memmert is the only manufacturer worldwide that offers digital pressure control. Ramp programming of temperature and vacuum (-cycles) in combination with heating/cooling of thermoshelves allows for quick processes and nullifies residual humidity.

Maximum time savings

The interior of all Memmert vacuum ovens can be ventilated in cycles to remove humidity quicker with the exhaust air. Thanks to ramp programming of temperature and vacuum cycles, the drying process is optimised and drying times are considerably further reduced in comparison to conventional vacuum drying ovens.

Up to 40 ramps with different set temperature and vacuum values can be directly programmed on the device or via the MEMoryCard. When using the "Celsius" software, the number of ramps is practically unlimited.

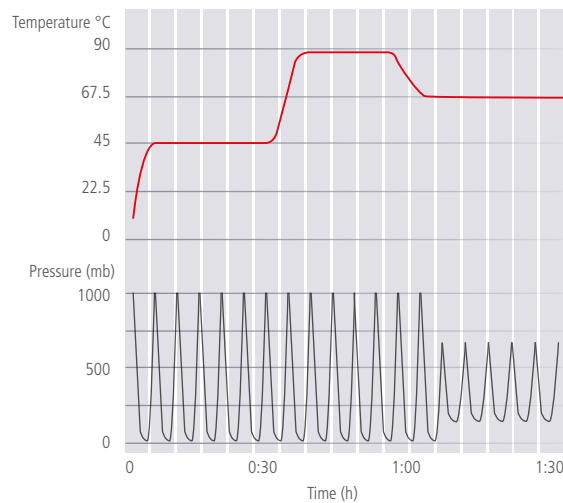

Peltier-element

COOLED VACUUM OVENS VOcool

according to DIN 12880:2007-05, EN 61010-1 (IEC 61010-1)



Standard equipment

- Interior:** Stainless steel interior, material 1.4404 (ASTM 316 L), hermetically welded, with removable mountings at the sides for cleaning, including thermoshelf guide bars, as well as mounting on top to avoid turbulences
- Internals:** Thermoshelf, aluminium, eloxadised material 3.3547 (ASTM B209)
- Housing:** Textured stainless steel, rear zinc-plated steel, aesthetic functional glass-stainless steel operating panel with multifunction display and input module, safety glass door with inner bullet-proof glass and external anti-splinter screen
- Installation:** 4 feet
- Connection:** Mains cable with plug (German type)
- Interfaces:**
 - USB
 - printer interface



Optional:

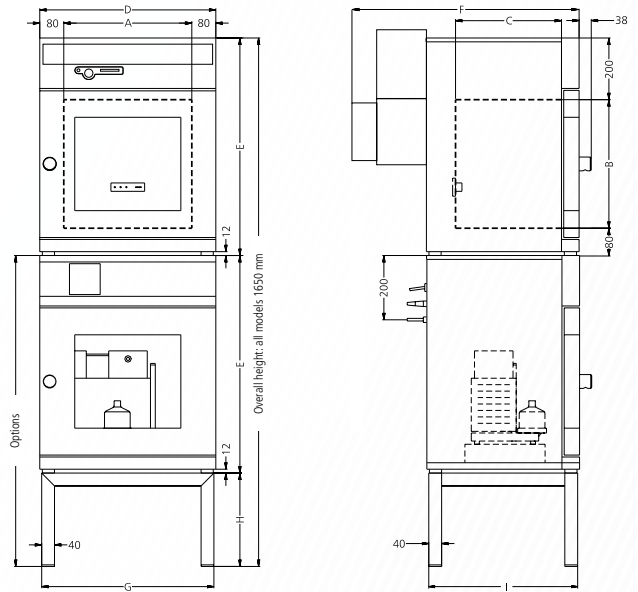

Model sizes/Description		200	400
Stainless steel interior	Volume	approx. l	29 49
	Width	(A) mm	385 385
	Height	(B) mm	305 385
	Depth	(C) mm	250 330
	Maximum load per shelf	approx. kg	20
Textured stainless steel housing <small>(The dimensions also apply to the optional pump module)</small>	Width	(D) mm	550 550
	Height	(E) mm	600 680
	Depth (without door handle, depth of handle 38 mm) incl. Peltier-cooling device CDP115	(F) mm	650 730
	Safety glass door: Textured stainless steel frame with spring-loaded safety glass on inside and anti-splinter screen ESG on outside of door		<input type="checkbox"/>
Door seal	Endless silicone profile seal		<input type="checkbox"/>
Temperature	Electronic microprocessor temperature controller with Pt100 and auto-diagnostic system		<input type="checkbox"/>
	Temperature sensor Pt100 Class A in 4-wire circuit individually for each thermoshelf		<input type="checkbox"/>
	Working-temperature range	°C	+5 to +90
	Setting temperature range	°C	+5 to +90
	Temperature variation in time (to DIN 12880:2007-05) (aluminium thermoshelf)	K	≤ ± 0.3
	Temperature uniformity (surface) at +20 °C/20 mbar	K	≤ ± 1
Pressure (vacuum)	Digital electronic pressure control (in programme operation up to 40 ramps, adjustable for each segment) for vacuum via solenoid valves. Tubing for vacuum, air and inert gas are made of material 1.4571 (ASTM 316 Ti). Adjustable from 5 mbar up to 1100 mbar. Programmable, digitally controlled inlet for air. Integrated process control with programmable temperature and vacuum cycles enabling amongst others accelerated moisture reduction.		<input type="checkbox"/>
	Rapid air intake for door opening without alteration of selected vacuum setpoint		<input type="checkbox"/>
	Permitted final vacuum	mbar	0.01
	Maximum leakage rate	bar/h	0.01
Monitor	Microprocessor temperature monitor acting as overtemperature protection (protection class 3.1) with Pt100, incorporating fault diagnostics with visual and acoustic alarm		<input type="checkbox"/>
	Digital over- and undertemperature monitor		<input type="checkbox"/>
	Temperature monitoring band automatically linked to the setpoint (ASF)		<input type="checkbox"/>
	Multi-Level-Overtemperature-Protection (MLOP) for each thermoshelf		<input type="checkbox"/>
	Relay for reliable heating cut-off in case of fault		<input type="checkbox"/>
	Acoustic alarms: Over- and undertemperature		<input type="checkbox"/>

Model sizes/Description		200	400	
Timer functions	Real-time/weekly programmer with group function (e.g. Monday – Friday)		<input type="checkbox"/>	
	Timer with residual running time: max. 40 ramps (each 1 min. up to 999 h) programmable through controller or MEMoryCard XL; programming via PC and free-of-charge software: unlimited number of ramps		<input type="checkbox"/>	
Documentation	Internal log memory 1024 kB as ring memory for all setpoints, actual values, errors, settings with real-time and date; capacity up to 3 months at 1 min. intervals		<input type="checkbox"/>	
	“Celsius” software for control and documentation of temperature and pressure		<input type="checkbox"/>	
	Parallel interface		<input type="checkbox"/>	
Setup	Calibration (no sep. PC required), temperature and pressure: 3-point calibration on controller		<input type="checkbox"/>	
	Setting of language for dialogue and display DE / EN / ES / FR / IT		<input type="checkbox"/>	
Connections	Vacuum connection with small flange DN16, and gas inlet with small flange DN 16		<input type="checkbox"/>	
Further data	Electrical load (loading with max. number of thermoshelves), at 230 V, 50/60 Hz	approx. W	400 500	
Standard accessories	Removable interior mounting – stainless steel material 1.4404 (ASTM 316 L) – with integrated lateral guide bars for thermoshelves		<input type="checkbox"/>	
	Thermoshelves – aluminium eloxadised, mat. 3.3547 (ASTM B209) – with integral large-area heating/cooling incl. local temperature sensing (Pt100, 4-wire-circuit); individual overtemp. protection for each shelf. Further data see stainless steel inner working chamber	number		1
	Works calibration certificate(s) (measuring point in the middle of the individual shelf for +160 °C at 20 mbar pressure): a separate certificate is prepared for each thermoshelf ordered and shipped together with the vacuum oven			<input type="checkbox"/>
	Removable bottom drip-tray made of stainless steel No. 1.4404 (ASTM 316 L)			<input type="checkbox"/>
	Inert gas inlet: programmable and digitally controlled inlet for inert gas with flow rate reduction			<input type="checkbox"/>
	Pump control: optimised rinsing procedures for the pump membranes as well as signal output for pump ON/OFF (recommended in combination with PMP)		<input type="checkbox"/>	
Packing data / Vacuum oven	Net weight/Gross weight (packed in carton)	approx. kg	64/85 92/113	
	Packed dimensions Width/Height/Depth	approx. cm	66/87/59 66/87/59	
Packing data / Pump module	Net weight without/with pump	approx. kg	25/41 30/46	
	Gross weight (packed in carton) without/with pump	approx. kg	46/62 51/67	
	Packed dimensions Width/Height/Depth	approx. cm	66/87/59 66/87/59	
Order No. Cooled Vacuum Ovens			VO200cool VO400cool	

Options	200	400
Extended temperature range (0 °C to +90 °C)		A8

Accessories	200	400
Removable bottom drip-tray made of stainless steel No. 1.4404 (ASTM 316 L)	E04256	E04257
Subframe, tubular steel, black enamelled (for stacking unit consisting of vacuum oven and pump module, total height: 1650 mm, see sketch of oven dimensions) Width/Height/Depth (see sketch of oven dimensions) G/H/I	E02030 mm 529/450/ 383	E02031 529/290/ 463
Works calibration certificate for 3 temperatures: +5 °C, +30 °C, +90 °C at 20 mbar pressure		D00133
Guarantee extension by 1 year (VO _{cool} only)		GA2Q5
Noise-insulated vacuum pump module without pump (exterior dimensions and -material No. s. vacuum oven) with antivibration metal plate at the bottom to accommodate the vacuum pump, incl. full-sight glass door. Socket, signal cable and connecting hose to the vacuum oven	PM200	PM400
Noise-insulated vacuum pump module, as above, however with built-in pump 230 V, 50/60 Hz (pump B04133 for VO200 and pump B04134 for VO400)	PMP200	PMP400
Signal cable (3 m) for optimising pump performance by demand-controlled activation of purge of Memmert pump		B04027
Vacuum connecting hose (3 m) from oven to Memmert pump incl. optimised connection accessories (partially stainless steel)		B04026
Chemically resistant vacuum pump with PTFE double diaphragm, pump capacity at atm. pressures: approx. 34 NI./min = 2,04 m ³ /h and autom. purge control from vacuum oven. Order No. B04027 and B04026 necessary. 230 V, 50 Hz. Max. guarantee period 2 years	B04133	–
Chemically resistant vacuum pump with PTFE double diaphragm, pump capacity at atm. pressures: approx. 60 NI./min = 3,6 m ³ /h and autom. purge control from vacuum oven. Order No. B04027 and B04026 necessary. 230 V, 50/60 Hz. Max. guarantee period 2 years	–	B04134

SOFTWARE AtmoCONTROL

AtmoCONTROL – The innovative control and logging software

Parameters such as temperature and humidity as well as the process time can be set directly at the ControlCOCKPIT.

Ramp programming is done via the control and logging software AtmoCONTROL, which features a completely new software design.

Drag, drop & go!

Numerical and graphic programming of complex processes is a thing of the past. Today, programming is done via AtmoCONTROL by means of the mouse or touchpad on your notebook. Even the most complex ramp programmes are created within minutes. Simply drag & drop the graphical symbols for the desired parameters to the input field and change the values according to your wishes with a mouse click.



Programme functions

SingleDISPLAY and TwinDISPLAY

- Reading out, managing and organising the data logger
- Saving the log memory in various formats
- Online monitoring of up to 32 connected appliances
- Optical alarms when the alarm limits individually set at the ControlCOCKPIT are exceeded
- Automatic alarm to one or several e-mail addresses

Additional functions

TwinDISPLAY

- Intuitive programming and archiving of ramps and programme sequences
- Synchronous visualisation of the created programme sequence during programming
- Application-specific repeat functions (loops) can be inserted within a temperature control programme in any place
- Simple creation of repeating weekly programmes
- Programming, managing and transferring programmes via Ethernet interface or USB port

SPECIAL EQUIPMENT FOR MODELS U, UF TS, UNpa, S, I, ICO, ICP, IPP, IPS, HPP, ICH

Options for models Modelle U, UF TS, UNpa, S, I, ICO, ICP, IPP, IPS, HPP, ICH	30	55	75	110	160	260	450	750	1060	50	105	150	240
Door with lock (safety lock); for models UF TS per side; standard with SN/SF and SNplus/SFplus 450 and 750 (not for models ICO)							B6						–
Door hinged on the left; for models UF TS per side				B8				–					B8
Potential-free contact (24 V/2 A) with socket to NAMUR NE 28 for external monitoring (indicates when setpoint is reached); models ICO: when set points of temperature and CO ₂ are reached								H5					
Potential-free contact for combination error message (e.g. supply failure, sensor fault, fuse)								H6					
Potential-free contact (24 V/2 A) with socket to NAMUR NE 28, for signal generation, controlled by programme segment, for free-selectable functions to be activated (e.g. activation of audible and visual signals, exhaust motors, fans, stirrers, etc.). Only for units with TwinDISPLAY; max. 2 contacts on 1-phase appliances; max. 4 contacts on 3-phase appliances (not for models ICO)							2 contacts 4 contacts	H72		H74			– –
Process-dependent door lock (only for units with TwinDISPLAY); for models UF TS see page 11; not for models ICO					D4								–
Door-open-recognition (only for units with TwinDISPLAY); for models UF TS per side; standard with ICO, ICH C, ICH L								V5					
Flexible Pt100 for positioning in chamber or in load with socket, 4-pin, according to NAMUR NE 28, for external temperature recording (load temperature) max. 3 sensors; not for models ICO								H4					–
Flexible Pt100 temperature sensor, positioned flexibly in chamber or load, for local temperature measurement (up to 3 additional sensors are possible). The measured temperature can, if required, be indicated on the display, recorded in the integral data store, and can be documented via the AtmoCONTROL software. Not for models ICO								H8					–
MobileALERT, notification by SMS in case of any error or alarm of the device. Requires option H6 "floating contact for alarm"									C3				
MobileALERT for up to 4 alarm notifications; standard: temperature and CO ₂ alarm, additionally humidity alarm (when equipped with option K7) and O ₂ alarm (when equipped with option T6)													C4
Temperature restriction (for UN/UF/UNplus/UFplus and models UF TS) Temperatures: +60, +70, +80, +95, +100, +120, +160, +180, +200, +220 or +250 °C (Please, indicate upon ordering)						A8							–
Castor frame (2-part), height 140 mm (not for models UF TS, ICP, ICH, ICH L, ICH C, ICO)													R9

SPECIAL EQUIPMENT FOR MODELS U, UF TS, UNpa, S, I, ICO, ICP, IPP, IPS, HPP, ICH

Accessories for models U, UF TS, UNpa, S, I, ICO, ICP, IPP, IPS, HPP, ICH	30	55	75	110	160	260	450	750	1060	50	105	150	240
USB-Ethernet adapter													E06192
Ethernet connection cable 5 m for computer interface													E06189
USB User-ID stick (with User-ID licence): Oven-linked authorisation licence (User-ID-programme) on Memory-stick, prevents undesired manipulation by unauthorised third parties. When reordering please specify serial number (only for units with TwinDISPLAY)													B33170
USB stick with documentation software AtmoCONTROL and operation manual for products with SingleDISPLAY (the standard equipment of appliances with TwinDISPLAY includes one USB stick with AtmoCONTROL)													B33172
Set of height adjustable feet (4 pcs) – standard on models ICO				B29768					–				B29768
Stacking set (4 pcs) for stacking of appliances of same size (not for models 160, 260, 450, 750, 1060, ICH110, ICH110L, ICH110C, ICO150, ICO240)		B29744						–		B29744			–
Plug-in tube extension (outer diam. 60.3 mm, inner 57 mm), straight, for exhaust air ducting (if necessary for connection by hose), only models U, I, S not for models UF TS						B29718							–
Plug-in tube extension (outer diam. 60.3 mm, inner 57 mm), angled, for exhaust air ducting (if necessary for connection by hose), only models U, I, S not for models UF TS						B29719							–
Flush-fit unit (stainless steel frame covering gap between oven and wall opening), with air slots – technical clarification required	B29728	B29730	B29732	B29734	B29736	B29738	B29740		B29742				–
Flush-fit unit (stainless steel frame covering gap between oven and wall opening), without air slots – technical clarification required; for models UF TS see page 11; not for models ICO	B29729	B29731	B29733	B29735	B29737	B29739	B29741		B29743				–
Subframe, adjustable in height (size 30 to 75: height 600 mm, size 110 to 450: height 500 mm); not for models ICO and UF TS	B29745	B29747	B29747	B29749	B29749	B29751	B29753						–
Subframe, on castors (size 30 to 75: height 660 mm, size 110 to 160: height 560 mm); not for models ICO and UF TS	B29746		B29748		B29750								–
Subframe, adjustable in height, height 130 mm, for example for units with fresh air filter; not for models ICO and UF TS	B33657		B33659		B33661		B33664						–
Software conforming to FDA AtmoCONTROL. Meets the requirements for the use of electronically stored data sets and electronic signatures as laid down in Regulation 21 CFR Part 11 of the US Food and Drug Administration (FDA). Base licence for the control of one unit (only for units with TwinDISPLAY)													FDAQ1
Integration of additional units (up to max. 15 units) into an already existent FDA-software licence (only for units with TwinDISPLAY)													FDAQ2
IQ document with device-specific works test data, OQ/PQ check list as support for validation by customer													D00124
IQ/OQ document with device-specific works test data, for one free-selectable temperature value incl. temperature distribution survey for 9 measuring points (size 30), 27 measuring points (sizes 55 – 1060) to DIN 12880:2007-05 (further temperature values on demand), PQ check list as support for validation by customer	D00125												D00127
IQ/OQ document with device-specific works test data, for one free-selectable temperature and humidity value incl. temperature distribution survey for 27 measuring points to DIN 12880:2007-05, PQ check list as support for validation by customer (models HPP and ICH)		–		D00136	–	D00136	–	D00136					–
IQ/OQ document with device-specific works test data, for one free-selectable temperature, humidity and light value incl. temperature distribution survey for 27 measuring points to DIN 12880:2007-05, PQ check list as support for validation by customer (models HPP with light and ICH L)		–		D00137	–	D00137	–	D00137					–
IQ/OQ document with device specific works test data for one free-selectable CO ₂ , humidity and temperature value, incl. temperature distribution survey for 27 measuring points to DIN 12880:2007-05, PQ check list as support for validation by customer (models ICH C and ICO; on models ICO a free-selectable humidity value is only possible with option K7)		–		D38897	–	D38897	–	D38897	–				D38897
IQ/OQ document with device specific works test data for one free-selectable CO ₂ and temperature value, incl. temperature distribution survey for 27 measuring points to DIN 12880:2007-05, PQ check list as support for validation by customer (models ICO)													D38898
External measuring instrument with sensors for daylight and UV-light. Product information on demand (models HPP, ICH L, IPPplus)						B04713							–
Ditto with additional measuring head for temperature and humidity measurement. Product information on demand (models HPP, ICH L, IPPplus)						B04714							–

SPECIAL EQUIPMENT FOR MODELS VO, VOcool, INCOmed, HCP, TTC, CTC

Options for models VO, VOcool, INCOmed, HCP, TTC, CTC	200	400	500	108	153	246	256
Interface Ethernet instead of USB including software							W4
RS232 interface instead of USB							W6
Computer interface RS485 (for networking a max. of 16 ovens) instead of RS232							V2
Door with lock (safety lock, not available for VO, VOcool, TTC/CTC)							B6
Flexible Pt100 for positioning in chamber or in load with socket, 4-pin, according to NAMUR NE 28, for external temperature recording (load temperature); for VO and VOcool on demand							H4
Additional Pt100 temperature sensor, positioned flexibly in chamber or load, for local temperature measurement (up to 3 additional sensors are possible). The measured temperature can, if required, be indicated on the multifunction display, recorded in the integral ring store, and can be documented via the "Celsius" software or on an attached printer. (Not available for VO, VOcool, TTC and CTC)							H8
Potential-free contact (24 V/2 A) with socket, according to NAMUR NE 28 for external monitoring (indicates when setpoint is reached)							H5
Potential-free contact (24 V/2 A), with socket, according to NAMUR NE 28 for combination error message (e.g. supply failure, sensor fault, fuse)							H6
Potential-free contact (24 V/2 A), with socket, according to NAMUR NE 28, triple, for signal generation, controlled by programme segment for a total of 3 freely selected functions to be activated (e.g. acoustic and visual signals, exhaust motors, fans, stirrers etc.)							H7
MobileALERT, notification by SMS in case of any error or alarm of the device. Requires option H6 "floating contact for alarm"							C3

Accessories for models VO, VOcool, INCOmed, HCP, TTC, CTC	200	400	500	108	153	246	256
USB connection cable for computer interface							E03643
Parallel/USB converter cable with integrated power supply unit to connect HP printers with USB interface to MEMMERT units							E05300
Documentation package consisting of parallel USB converter cable including PCL3-compatible HP colour inkjet printer with USB interface (HP OfficeJet 6000 or successor) for direct connection of printer to Memmert unit							B04432
Temperature profile write/read unit for programming via PC, for writing to and reading from the chip card, up to 40 ramps							E05284
Additional chip card, blank, formatted (32 kB MEMoryCard XL for a maximum of 40 ramps). Not available for INCOmed models							E04004
Oven-linked authorisation card (User-ID-Card) prevents undesired manipulation by unauthorised third parties. When reordering please specify serial number							E04159
Software conforming to FDA "Celsius FDA Edition". Meets the requirements for the use of electronically stored data sets and electronic signatures as laid down in Regulation 21 CFR Part 11 of the US Food and Drug Administration (FDA). Base licence for the control of one unit							E05019
Integration per additional unit (up to max. 15 units) into an already existent FDA-software licence (E05019)							FDAQ4
IQ check list with device-specific works test data as support for validation by customer							D00103
OQ check list with device-specific works test data for one free-selectable temperature value incl. temperature distribution survey for 27 measuring points to DIN 12880:2007-05 as support for validation by customer							D00104
OQ check list with device-specific works test data for one free-selectable temperature value incl. temperature distribution survey for 5 measuring points to DIN 12880:2007-05 as support for validation by customer valid for one thermoshelf; ditto for further thermoshelves VO on demand (VO and VOcool only)							D00117
OQ check list with device-specific works test data for one free-selectable humidity and temperature value incl. temperature distribution survey for 27 measuring points to DIN 12880:2007-05 as support for validation by customer (models HCP and CTC)							D00104
OQ check list with device-specific works test data for one free-selectable CO ₂ , humidity and temperature value incl. temperature distribution survey for 27 measuring points to DIN 12880:2007-05 as support for validation by customer (models INCOmed)							D00104
External measuring instrument with sensors for daylight and UV-light, with additional measuring head for temperature and humidity. Product information on demand (models INCOmed and HCP)							B04714

MODEL VARIANTS

SingleDISPLAY ControlCOCKPIT with one TFT display	TwinDISPLAY ControlCOCKPIT with two TFT displays
<p>AVAILABLE APPLIANCES</p> <p>UN / UF / IN / IF / SN / SF / IPP / IPS</p>	<p>AVAILABLE APPLIANCES</p> <p>UNplus / UFplus / UF TS / UNpa / INplus / IFplus / SNplus / SFplus ICO / IPPplus / ICP / HPP / ICH</p>
<p>One high-resolution TFT colour display with touch-sensitive buttons for selection of functions</p>	<p>Two high-resolution TFT colour displays with touch-sensitive buttons for selection of functions</p>
<p>Available parameters on the ControlCOCKPIT: Temperature (Celsius or Fahrenheit), fan speed, exhaust air flap position, programme time</p>	<p>Available parameters on the ControlCOCKPIT: Temperature (Celsius or Fahrenheit), fan speed, exhaust air flap position, programme time, relative humidity, illumination, CO₂</p>
<p>One temperature sensor Pt100 DIN class A in a 4-wire circuit</p>	<p>Two Pt100 sensors DIN class A in a 4-wire circuit for mutual monitoring, taking over functions in case of an error</p>
	<p>HeatBALANCE function for application specific adjustment of heat output distribution (balance) between the upper and lower heating groups in an adjustment range between -50 % and +50 % (not valid for models 30, HPP110, IPP110plus, ICP, ICH)</p>
<p>AtmoCONTROL software for reading out, managing and organising the data logger via Ethernet interface (temporary trial version can be downloaded). USB stick with AtmoCONTROL software available as accessory (on demand)</p>	<p>AtmoCONTROL software on a USB stick for programming, managing and transferring programmes via Ethernet interface or USB port</p>
	<p>ControlCOCKPIT with USB port for uploading programmes, reading out protocol logs, activating the User-ID function</p>
	<p>Displaying of already logged protocol data on the ControlCOCKPIT (max 10,000 values correspond to approx. 1 week)</p>
<p>Ethernet interface on the rear of the appliance for reading out the protocol log and for online logging</p>	<p>Ethernet interface on the rear of the appliance for reading out the protocol log and for uploading programmes and for online logging</p>
<p>Double overtemperature protection: Electronic temperature monitoring with freely adjustable monitoring temperature, for models U, I, S with option A6 TWW/TWB (protection class 3.1 or 2), mechanical temperature limiter TB acc. to DIN 12880</p>	<p>Multiple overtemperature protection: Electronic temperature monitoring TWW/TWB (protection class 3.1 or 2 resp. 3.3 for units with active cooling) and mechanical temperature limiter TB (protection class 1) acc. to DIN 12880, AutoSAFETY automatically adjusts to the set value within a freely adjustable tolerance range. Setting individual MIN / MAX values for over/undertemperature alarm and also for all other parameters such as relative humidity, CO₂</p>
<p>PID microprocessor control with integrated auto-diagnostic system</p>	
<p>Structured stainless steel housing, scratch-resistant, robust and durable; rear of zinc-plated steel</p>	
<p>High-temperature connectors on the rear of the appliance for single-phase power connection according to country specific systems and IEC standards</p>	
<p>Internal data logger with a storage capacity of at least 10 years</p>	
<p>German, English, French, Spanish language settings available on the ControlCOCKPIT</p>	
<p>Digital backwards counter with target time setting, adjustable from 1 minute to 99 days</p>	
<p>The SetpointWAIT function guarantees that the process time does not start until the set temperature is reached at all measuring points – optional for temperature values recorded by the freely positionable Pt100 sensors inside the chamber</p>	
<p>Adjustment of three calibration values for temperature and additional appliance specific parameters directly at the ControlCOCKPIT</p>	



memmert
Experts in Thermostatics

YOUR MEMMERT PARTNER

HEATING AND DRYING OVENS

UNIVERSAL OVEN U

PASS-THROUGH OVEN UF TS

PARAFFIN OVEN UNpa

STERILISER S

VACUUM OVEN VO

COOLED VACUUM OVEN VOcool

INCUBATORS

INCUBATOR I

CO₂ INCUBATOR ICO

CO₂ INCUBATOR INCOmed

COMPRESSOR-COOLED INCUBATOR ICP

PELTIER-COOLED INCUBATOR IPP

COOLED STORAGE INCUBATOR IPS

CLIMATE CHAMBERS

CONSTANT CLIMATE CHAMBER HPP

HUMIDITY CHAMBER HCP

CLIMATE CHAMBER ICH

ENVIRONMENTAL TEST CHAMBER CTC/TTC

WATERBATHS / OILBATHS

WATERBATH W

OILBATH O

Memmert GmbH + Co. KG
P.O. Box 1720 | D-91107 Schwabach
Tel. +49 9122 925-0 | Fax +49 9122 14585
E-Mail: sales@memmert.com
facebook.com/memmert.family
The platform for experts: www.atmosafe.net