



# MICRO FEED THROUGH TERMINAL SUT 4

## accessories



CAT#    STD. PKG.    WT/STD.PKG-KG

END PLATE		ES4	100	0.12
PARTITION PLATE WITHOUT FOOT		—	—	—
PARTITION PLATE WITH FOOT		—	—	—
SUPPORT FOR PROTECTION COVER		—	—	—
PROTECTION COVER		—	—	—
END CLAMPS		SCMN	100	0.25
		—	—	—
		—	—	—
		—	—	—
MARKING LABEL		LABEL KN 5.5	100 STRIPS	0.08
WARNING LABEL		—	—	—
GROUP MARKING CARRIER		—	—	—
		—	—	—
		—	—	—
		—	—	—

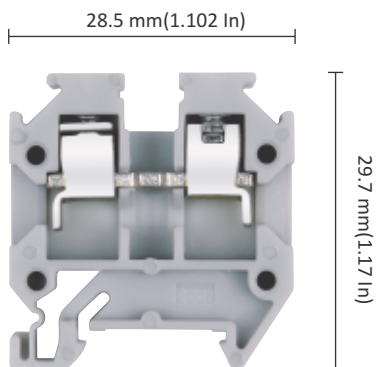
TERMINAL PITCH	6 mm(0.24 Inch)		
RATED CROSS SECTION	4 sq mm		
CONNECTION	Flexible	0.5 sq mm - 4 sq mm	
POSSIBILITY	Rigid	0.5 sq mm - 4 sq mm	
WIRE STRIPPING LENGTH	8 mm		
TYPE OF CONNECTION	2 screw clamps and 1 tapped hole for cross connection		
SCREW SIZE	M3		

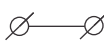

SUT 4

LINE REPRESENTATION	TOOL DETAILS	SUGGESTED LUG TYPE	STANDARD COMPLIANCE			
			IEC	UL	CSA	ATEX
		Flat	60947-7-1	1059	22.2 No.158	60079-7
	Ø 5	Round				

## inter connecting accessories





CAT#    STD. PKG.    WT/STD.PKG-KG

TERMINAL TYPE	SUT 4	100	0.57
---------------	-------	-----	------

	VOLTAGE	RATED CROSS SECTION	CURRENT	TORQUE	
RATING	IEC	500 V	4 sq mm	32 A	0.5 Nm
	CSA/UL	300 V	12-24 AWG	22 A	4.5 Lbln

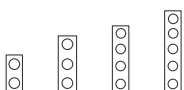

COLOUR:	
G - GREY, K - KHAKHI	SUT 4(G) SUT 4(K)
R - RED, Y - YELLOW, B - BLUE	SUT 4(R) SUT 4(Y) SUT 4(B)
BL - BLACK, GR - GREEN	SUT 4(BL) SUT 4(GR)

MOUNTING CHANNEL	CHM10	100	30
STANDARD LENGTHS	—	—	—
300 mm, 500 mm, 1000 mm	—	—	—
	—	—	—



SHORTING LINK ASSEMBLY	- 2 WAY	CCLA DD	100	0.25
	- 3 WAY	CCLA DD	100	0.38
	- 4 WAY	CCLA DD	100	0.51
	- 5 WAY	CCLA DD	50	0.32
	- 10 WAY	CCLA DD	50	0.65
PERMANENT SHORTING LINK	- 2 WAY	—	—	—
	- 3 WAY	—	—	—
	- 4 WAY	—	—	—
	- 5 WAY	—	—	—
	- 10 WAY	—	—	—
STUD FOR PERMANENT SHORTING LINK		—	—	—
COMB LINK	- 2 WAY	SLC4N	100	0.20
	- 3 WAY	SLC4N	100	0.30
	- 4 WAY	SLC4N	100	0.40
	- 5 WAY	SLC4N	50	0.25
	- 10 WAY	SLC4N	50	0.50
REMOVABLE SHORTING LINK		—	—	—
STUD FOR REMOVABLE SHORTING LINK		—	—	—







# accessories

		CAT#	STD. PKG.	WT/STD.PKG-KG
END PLATE		EPP	100	0.25
PARTITION PLATE WITHOUT FOOT		—	—	—
PARTITION PLATE WITH FOOT		—	—	—
SUPPORT FOR PROTECTION COVER		—	—	—
PROTECTION COVER		—	—	—
END CLAMPS		SCMN	100	0.25
				
MARKING LABEL		LABEL KN 5.5	100 STRIPS	0.08
WARNING LABEL		—	—	—
GROUP MARKING CARRIER		—	—	—
		—	—	—
		—	—	—
		—	—	—

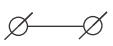
# MICRO FEED THROUGH TERMINAL PET 4

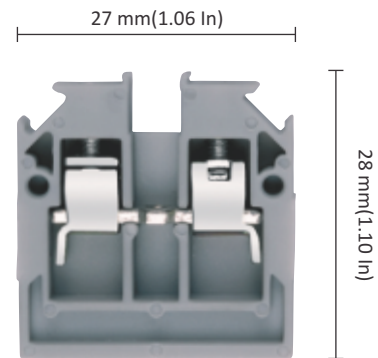

TERMINAL PITCH	6 mm(0.24 Inch)		
RATED CROSS SECTION	4 sq mm		
CONNECTION	Flexible	0.2 sq mm - 4 sq mm	
POSSIBILITY	Rigid	0.2 sq mm - 4 sq mm	
WIRE STRIPPING LENGTH	9 mm		
TYPE OF CONNECTION	2 screw clamps and 1 tapped hole for cross connection		
SCREW SIZE	M3		

LINE REPRESENTATION	TOOL DETAILS	SUGGESTED LUG TYPE	STANDARD COMPLIANCE			
			IEC	UL	CSA	ATEX
	 Ø 5	Flat  Round 	60947-7-1	—	—	60079-7



PET 4

# inter connecting accessories

		CAT#	STD. PKG.	WT/STD.PKG-KG
SHORTING LINK ASSEMBLY	- 2 WAY	CCLA DD	100	0.25
	- 3 WAY	CCLA DD	100	0.38
	- 4 WAY	CCLA DD	100	0.51
	- 5 WAY	CCLA DD	50	0.32
	- 10 WAY	CCLA DD	50	0.65
PERMANENT SHORTING LINK	- 2 WAY	—	—	—
	- 3 WAY	—	—	—
	- 4 WAY	—	—	—
	- 5 WAY	—	—	—
	- 10 WAY	—	—	—
STUD FOR PERMANENT SHORTING LINK		—	—	—
COMB LINK	- 2 WAY	SLC4N	100	0.20
	- 3 WAY	SLC4N	100	0.30
	- 4 WAY	SLC4N	100	0.40
	- 5 WAY	SLC4N	50	0.25
	- 10 WAY	SLC4N	50	0.50
REMOVABLE SHORTING LINK		—	—	—
STUD FOR REMOVABLE SHORTING LINK		—	—	—

	CAT#	STD. PKG.	WT/STD.PKG-KG
TERMINAL TYPE	PET 4	100	0.57

	VOLTAGE	RATED CROSS SECTION	CURRENT	TORQUE	
RATING	IEC	500 V	4 sq mm	32 A	0.5 Nm
	CSA/UL	—	—	—	—

COLOUR:	
G - GREY, K - KHAKHI	PET 4(G) PET 4(K)
R - RED, Y - YELLOW, B - BLUE	PET 4(R) PET 4(Y) PET 4(B)
BL - BLACK, GR - GREEN	PET 4(BL) PET 4(GR)
MOUNTING CHANNEL STANDARD LENGTHS	Not Applicable
300 mm, 500 mm, 1000 mm	
