



# NEW HOLLAND

## **B110<sub>B</sub>**



COMMON RAIL TIER 3A ENGINE

MECHANICAL OR PILOT "COMMAND CONTROLS"

HIGH FRONT LOADER PERFORMANCE



**NEW HOLLAND**

CONSTRUCTION

**BUILT AROUND YOU**

# B110B

## CNH COMMON RAIL TIER 3 A ENGINE

- Increased torque
- Increased performance
- Increased productivity with lower pollution

## BEST AVAILABLE HYDRAULIC SYSTEM

- Load sensing, closed centre
- Maximum power available where needed
- Simultaneous movements under every load

## COMFORT & SAFETY

- Outstanding spacious operator cab
- All-round cinemascope visibility
- Choice of backhoe: piloted or mechanical



## EASY MAINTENANCE AND SERVICEABILITY

- New tiltable engine hood for wide, easier ground level access to main components
- Automatic belt tensioner
- Extended oil change intervals

## CHOICE OF POWERFUL & COMFORTABLE TRANSMISSIONS

- Powershuttle version 4x4
- Full Powershift version 4x2
- Enhanced traction force



# B110B POWER

## TIER 3A COMMON RAIL ENGINE



This new generation CNH **Common Rail** engine represents "state of the art" technology, designed to increase performance and production whilst reducing fuel consumption and pollution.

The Common Rail system guarantees that fuel is injected in the cylinders at very high pressure, thus optimising its nebulization and its mix with an increased quantity of turbocharged and after cooled air. Moreover, the quantity of fuel introduced in the cylinders is electronically controlled so that the "right quantity" is injected at the "right moment" and combined with extra fresh air to provide peak efficiency output from the engine, whilst reducing fuel consumption and emissions of dangerous pollutants. At the same time, noise is also considerably lowered.

# FOR PRODUCTION



Increased performance, which means **increased torque and higher productivity**, combined with its environmentally friendly attitude, makes the B110B particularly suitable for work in urban or populated areas.

**A new, durable, efficient, comfortable and economic engine which contributes to a reduction in operating costs, thereby increasing your profit.**

# B110B

# INTELLI

## LOAD SENSING - CLOSED CENTRE MAXIMUM POWER WHERE NEEDED

**T**he B110B features an **integrated** Hydraulic and Steering System. It consists of two gear type pumps mounted in series with a total delivery of 170 l/min, **Load Sensing** regulated and working at a maximum pressure of 210 bars. When the machine is steering, the steering wheel first actuates the Orbitrol steering valve, then - via a priority valve - the increased flow required for faster steering effect is diverted from one of the two hydraulic gear pumps.



### FRONT LOADER

**I**f the operator is using the front attachment, when required, a special button on the new loader control lever disconnects the transmission so that total engine power is utilised as hydraulic power on the front loader for maximum productivity and efficiency.



**T**he **handle on the loader control lever**, includes:

- a “rocker”, to proportionally control the additional hydraulic function. It allows, for example, use of the 4-in-1 bucket as a pincer, thus dramatically expanding the New Holland backhoe loader’s flexibility
- the horn button (only PowerShift version)
- the transmission disconnect button to utilise the optimum available hydraulic power on the front attachment for maximum productivity and efficiency.

### BACKHOE

**I**f backhoe is in operation, thanks to its **Closed Centre** main control valve, the hydraulic system delivers its power when and where it is needed, while simultaneous movements are allowed independently from power required and engine r.p.m., for maximum performance, faster cycle times and maximum production.

# GENT HYDRAULICS



## **HED (Hydraulic Extending Dipper)**

**A** HED (Hydraulic Extending Dipper) is available as an option for maximum reach, digging depth and loading ability whilst optimising the special New Holland design of the complete backhoe. The New Holland backhoe features a strong box section boom and a narrow dipper, so visibility is excellent down the length of the boom to the bucket at all digging depths. Finally, the externally mounted "in line" cylinder design contributes to visibility whilst providing the best utilization of hydraulic force for maximum efficiency.



Both transmissions, which can be fitted on request on the B110B, are designed to best match the increased torque of the common rail engine. They efficiently follow the quicker response of the new engine to the operator demand and translate it into higher traction. This means shorter cycles and superior pushing capability in front loader operations, thus providing higher productivity and customer profit.



## 4x4 POWERSHUTTLE TRANSMISSION

The synchronised, four speed modulated PowerShuttle transmission enables operators to shuttle between forward and reverse quickly and smoothly. This eliminates shock load in the driveline components, increasing durability, enhancing operator comfort and giving safer control of load handling.



# ATE THE GROUND



## 4x2 FULL POWERSHIFT TRANSMISSION

**P**owershift provides smooth gear shifting and directional changes under load for maximum operator comfort and convenience and can be chosen as option on the New Holland B110B.

It can operate in both manual and automatic mode. With manual mode selected, the operator simply twists the steering column-mounted selector to change through the gears. In “full automatic mode” the transmission will auto-shift either up or down depending on speed or load, improving cycle times and simplifying road travel.

An efficient, economic and comfortable mode.

KICK DOWN function for a real wheel loader performance.



# Enjoy the



# power



## T DIAGNOSTIC PORT

To monitor and diagnose the main machine components, the service technician can easily and quickly use the electronic connector Port, located on the front right side of the cab interior. Then, by simply connecting a laptop, he can detect and correct any minor malfunctions or unexpected minor diagnostic problems which need to be solved directly on the specific component.



# MAINTENANCE



## EASY ACCESS TO ALL SERVICE POINTS

**T**he B110B is designed for simple and easy maintenance and service procedures, thanks to its new tiltable engine hood which grants excellent ground level access to all the most important components. Easy and regular maintenance of the machine, such as control of air filter status and engine oil levels, change of oil filter, check of the Electronic Engine Controller and so on, can only improve durability and reliability, already designed and built-in by New Holland engineers.



## ONE LOCATION CHECK POINTS

**O**n the machine's left side, just above the fuel tank, you can easily reach the pressure check points for the main hydraulic system, steering circuit and pilot control, all grouped together for time and cost reduction whilst improving efficiency, durability and performances of your B110B.



## PROTECTED BATTERY

**T**he battery is both well protected and easy to reach for regular checks, in the box located on the right side, underneath the cab. By simply removing a panel it is possible to reach it and the master switch.



**Proactive maintenance assistance to improve machine durability, increase performance and reduce operating costs.**

# B110B

# COME



## T SPACE CAB

The features and customer advantages of the B110B cab are so many that they cannot be summarised in a single sentence. "Space Cab" best describes it as it is incredibly roomy, with ample glass area to assure all-round cinemascopic visibility. Controls are ergonomically positioned, easy to reach and to read. Side windows can be fully or partially opened for good ventilation whilst, for the most severe climatic conditions, optional air conditioning is available. From his adjustable seat, the operator has his "world" under complete and comfortable control. For operator safety, the cab has an integral **ROPS** and **FOPS** structure and can be supplied with an optional electronic engine immobiliser.

# COMFORT AND SAFETY



## P.C.C. (PILOT COMMAND CONTROLS)\*

**B**ackhoe Pilot Command Controls, like those used on the latest generation excavators, are available on the B110B to provide operators with an extremely comfortable working environment. They guarantee a personalised working position, as manipulators may be moved and adjusted longitudinally and laterally. In addition, two tiltable and vertically adjustable wrist rests offer perfect support to operate joysticks with surgical precision.

To suit operator requirements, command can be switched between backhoe and excavator pattern on demand, whilst the pilot control can be quickly disabled for safety reasons.

\* In alternative simple and effective mechanical controls are available



## DECELERATION BUTTON

**T**he right manipulator is now equipped with a **new button** which, when pushed, returns the engine r.p.m. to Idle. It contributes to a reduction in fuel consumption and the operator can avoid continuous use of the hand throttle, located on the instrument panel, for maximum economy and comfort.



## INSTRUMENT PANEL

**T**he B110B is equipped with a completely new, elegant car-style instrument panel which groups, on the cab right-hand side, the ignition key, the function buttons, high visibility analogic gauges, which monitor engine coolant and oil temperature, engine r.p.m., battery charge and fuel levels. In addition, there is a complete set of warning and signal lights, allowing the operator to constantly monitor the main machine parameters.

A further innovation is now offered as standard on the B110B: the engine r.p.m. can be electronically and independently controlled by the dial type throttle, located on the instrument panel, or by a foot pedal.

If the operator is using the front loader, the foot pedal is much more instinctive and practical whilst, when using the backhoe, he can set the required r.p.m. via the dial type throttle. When not digging, he can return the engine to idle, just by pushing the deceleration button on the right manipulator.

A simple but practical solution designed by New Holland engineers to help operators to perform better and more easily, in the most comfortable and productive way.

**A cab designed for maximum operator comfort and safety thus allowing him to fully concentrate on the job for higher productivity and for a quick return on investment.**

# B110B

## SPECIFICATIONS



### ENGINE TIER 3A

Maximum power (ISO 14396/ECE R 120) .....82 kW/110 hp  
 Rated engine speed .....2200 rpm  
 Make and mode .....CNH 445TA/EGH  
 Type.....Diesel, 4 stoke, Common Rail, Direct injection,  
 Turbo, Aftercooler

Displacement.....4.5 l  
 Number of cylinders .....4  
 Bore x stroke .....104 x 132 mm  
 Maximum torque at 1400 rpm.....52 daNm

#### Electronic engine control, dial type

**Deceleration button: returns engine to minimum rpm when activated.**

**-23°C outside temperature start as standard equipment**

*The engine complies with 97/68/EC standards TIER 3A*



### ELECTRICAL SYSTEM

Voltage .....12 V  
 Alternator .....90 A  
 Starter motor .....2.7 kW  
 Standard maintenance-free battery.....1  
 Capacity.....95 Ah



### HYDRAULIC SYSTEM

Load sensing, closed centre hydraulic system to maximise power exploitation and outstanding digging performance, top lifting capacity and fast loading cycle

Pumps .....2 gear type  
 Total maximum flow .....170 l/min  
 Max working pressure .....210 bar

#### BACKHOE CONTROL

Choice of:

**Mechanical Controls** to provide simple and precise movements  
**Pilot “Command Controls”** to assure effortless and precise movements with extremely comfortable working conditions.

Pilot Command Controls and wrist rests are fully adjustable to guarantee the most ergonomic operator position for maximum productivity. For safety, Pilot Controls can be switched-off.

#### LOADER CONTROL

Multifunction lever with a new handle which includes proportional control for auxiliary hydraulic function (i.e. 4 in 1 bucket) and transmission disconnect button to maximise productivity and efficiency of front loader



### CAB AND CONTROLS

High Space cab designed with the operator in mind to offer spacious and ergonomic environment and outstanding cinemascope, all-round visibility. Operator comfort is assured thanks to fully adjustable seat, mechanical or air suspension type and - fully or partially - opening side windows for good through-flow ventilation. New instrument panel to provide perfect visibility and control of all major machine parameters and a quick access to electronic engine diagnostic port.



### TRANSMISSION

Choice between:

**Synchronised 4 x 4 Power Shuttle** transmission to ensure forward & reverse quick and smooth shifting, resulting in high operator comfort.

Torque converter stall ratio .....2.34:1

#### Forward speeds

	km/h
1.....	6.3
2.....	10.2
3.....	21.8
4.....	38.9

#### Reverse speeds

	km/h
1.....	7.6
2.....	12.3
3.....	26.2
4.....	46.4

**4 x 2 Full Power Shift** transmission to provide very smooth under load gear shifting and direction change, resulting in maximum operator comfort and productivity.

**Kick Down** function for real wheel loader performances

Torque converter stall ratio .....2.31:1

#### Forward speeds

	km/h
1.....	6.0
2.....	11.2
3.....	21.8
4.....	38.9

#### Reverse speeds

	km/h
1.....	7.1
2.....	13.2



### BRAKES

**Service brakes** .....oil bath disc brakes, 4 per side on rear axle, mechanically operated by independent right and left pedals, which may be mechanically locked together. A three position switch in the cab, allows the operator to select:

- rear wheel drive brakes
- all wheel drive brakes
- rear wheel drive, all wheel brakes

**Parking brake** .....caliper disc brake on transmission output shaft.



### STEERING SYSTEM

Type .....ORBITROL with priority valve on one gear pump of the hydraulic system

Turning radius\*:

Outside tyres .....4400 mm  
 Bucket corner.....5700 mm

\* Tyre size may effect turning radius.



### TYRES

Front	Rear
12.5 - 18	18.4 - 26
320/80 - R 18	480/80 - R 26
12.5 - 18	16.9 - 28



### CAPACITIES

	Litres
Fuel tank.....	125
Hydraulic tank.....	40
Hydraulic system.....	118
Engine cooling system.....	24
Engine oil.....	14
Transmission oil:	
Power Shuttle.....	18
Power Shift.....	14



# STANDARD EQUIPMENT

- 12V power socket
- 2+2 front and rear working lights
- 2-4 wheel drive mode selector
- 40km/h travel speeds
- Adjustable opening windows
- All tinted glass
- Alternator 90A
- Backup alarm
- CNH Tier 3A Common Rail diesel engine
- Control lamps:
  - Master warning and stop alert
  - Low and high beams
  - Brake oil level and temperature
  - Engine oil pressure
  - Engine air filter clogging indicator
  - Parking brake
  - Transmission oil pressure
  - Hydraulic oil filter clogging indicator
  - Air conditioning operating and fault indicator
  - Low fuel
- Electronic throttle controls with hand potentiometer and fly-by-wire pedal
- Free maintenance battery, 95 Ah
- Front and rear windshield wipers
- Front attachment with automatic return to dig
- Front counterweight
- Fuel filter with water separator
- Gauges for:
  - Engine coolant temperature
  - Transmission oil temperature
  - Engine rpm
  - Battery charge
  - Fuel level
- Ground line fuel fill with 125 litre capacity
- Horn
- Instrument panel with diagnostic port
- Load sensing, closed centre hydraulic system
- Multidisc oil bath brakes
- Rear axle with differential lock
- Road travel lights
- ROPS/FOPS cab with heating system
- Side mirrors
- Side shift
- Stabilisers control
- Transmission disconnect button

# OPTIONS

- 20km/h travel speed
- Additional counterweight
- Additional working lights
- Air conditioning
- Anti-theft device
- Backhoe buckets
- Backhoe quick coupler
- Biological hydraulic oil
- Cyclonic air pre-filter
- Dual batteries
- Front wheel fenders
- Hammer circuit
- Industrial or agricultural tyres
- Loader buckets
- Loader lock-out valves
- Loader quick coupler
- Mechanical or air suspension seat with belt
- Mechanical or pilot control
- Object handling kit with backhoe lifting hook and safety valves
- Powershuttle 4+4 or Powershift 4+2 transmission
- Road homologation
- Rotating beacon
- Stabiliser pads
- Standard or HED dipperstick
- Tool box

# B110B

## DIMENSIONS

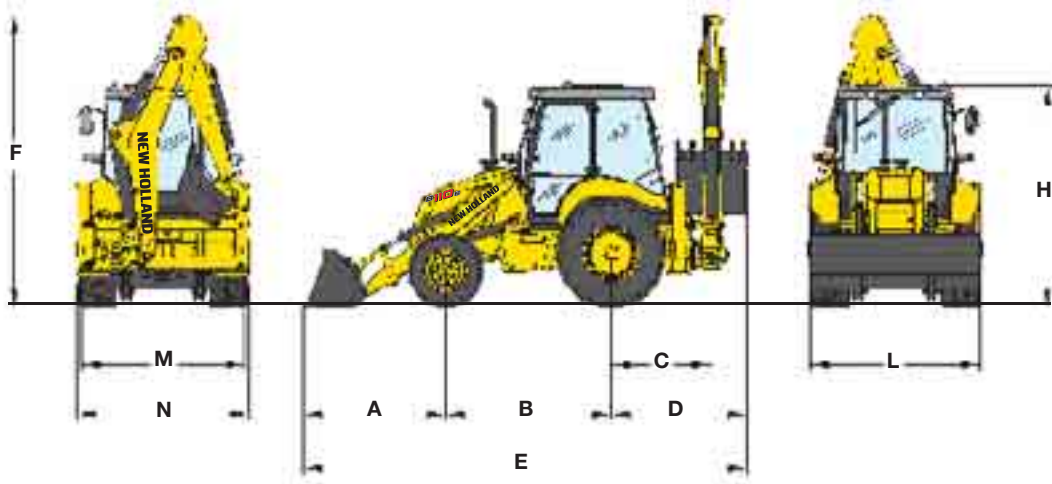

### OVERALL DIMENSIONS

<b>A</b> Ground distance over front axle	mm	1870
<b>B</b> Wheelbase	mm	2175
<b>C</b> Pivot distance over rear axle	mm	1320
<b>D</b> Max distance over rear axle (with 915mm backhoe bucket)	mm	1780
<b>E</b> Overall length	mm	5825
<b>F</b> Height to top of boom	mm	3825
<b>G</b> Back ramp angle	°	23°
<b>H</b> Cab height	mm	2940
<b>L</b> Loader bucket width	mm	2250
<b>M</b> Stabiliser width	mm	2250
<b>N</b> Overall width	mm	2325

OPERATING WEIGHT		STD DIPPER	HED DIPPER
Standard Bucket 1 m <sup>3</sup>	kg	7630	7860
4x1 bucket 1 m <sup>3</sup>	kg	7960	8190
6x1 bucket 1 m <sup>3</sup>	kg	8120	8350



LOADER BUCKET		STANDARD BUCKET	STANDARD BUCKET W/FORKS	4x1 BUCKET	6x1 BUCKET
Sae Capacity	m <sup>3</sup>	1.00	1.00	1.00	1.00
Weight	kg	410	570	740	900
Width	mm	2250	2250	2250	2250

BACKHOE BUCKET						
Sae Capacity	m <sup>3</sup>	0.08	0.14	0.20	0.26	0.32
Weight	kg	110	132	150	172	193
Width	mm	305	460	610	760	915

# B110B

## WORKING RANGE

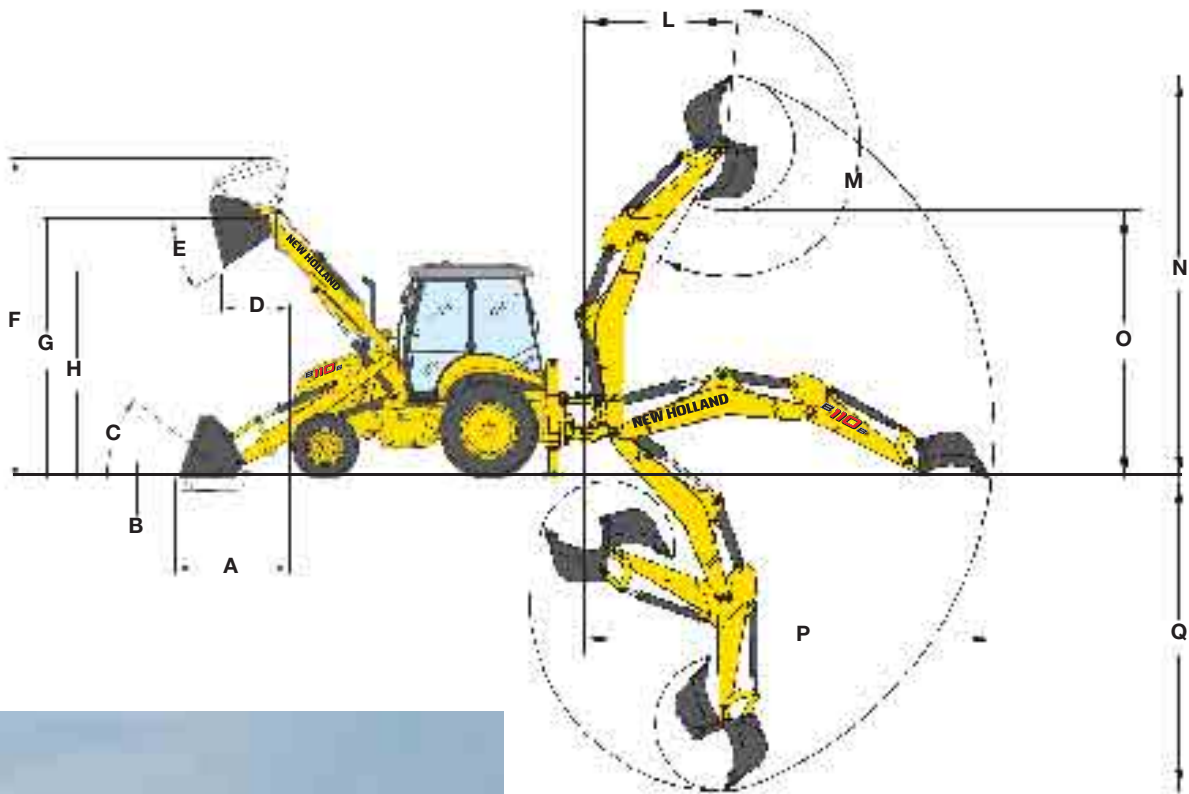

### LOADER SPECIFICATIONS

<b>A</b> Reach at ground level	mm	1500
<b>B</b> Digging depth	mm	75
<b>C</b> Bucket roll back angle on ground	°	40
<b>D</b> Reach at full height	mm	785
<b>E</b> Bucket dump angle at full height	°	45
<b>F</b> Maximum operating height	mm	4330
<b>G</b> Hinge pin height	mm	3500
<b>H</b> Dump height	mm	2780

Maximum loader breakout force	daN	6300
Lifting capacity to maximum height	kg	3550

### BACKHOE BREAKOUT FORCE

Bucket	daN	6400
Dipper breakout force (Std Dipper/HED retracted)	daN	4620
Dipper breakout force (HED extended)	daN	3200

BACKHOE SPECIFICATIONS		STD DIPPER	STD DIPPER HED RETRACTED	HED EXTENDED
<b>L</b> Digging reach at max height	mm	2330	2330	3190
<b>M</b> Bucket rotation	°	204	204	204
<b>N</b> Digging height	mm	5650	5650	6305
<b>O</b> Dumping height	mm	3930	3930	4585
<b>P</b> Digging reach at ground level	mm	5860	5860	6815
<b>Q</b> Digging depth	mm	4710	4710	5750

Machine equipped with: front tires 12.5/18, rear tires 18.4-26; base counterweight; standard bucket 1 m<sup>3</sup>.

# NEW HOLLAND. THE POWER OF A GLOBAL BRAND

New Holland is a global brand with a key position in the Construction Equipment business. It supplies a complete range of 13 product lines and 80 basic models split into Compact line and Heavy line. It operates in all the main markets, such as Europe, North and Latin America, Africa, Asia and Middle East with the same technology and under the same logo and brand. It manufactures durable, safe and productive machines aimed at supporting customers in developing their own business. Dealers are company partners. They play an important role to support the brand in their territories through intense professional relationship with Customers. New Holland is reinforced by its global alliance with Kobelco: world leader in hydraulic excavator technology.



AT YOUR OWN DEALERSHIP

The information contained in this brochure is intended to be a general nature only. The NEW HOLLAND KOBELCO CONSTRUCTION MACHINERY S.p.A. company may at any time and from time to time, for technical or other necessary reasons, modify any of the details or specifications of the product described in this brochure. Illustrations do not necessarily show products in standard conditions. The dimensions, weights and capacities shown herein, as well as any conversion data used, are approximate only and are subject to variations within normal manufacturing techniques.

Published by NEW HOLLAND KOBELCO CONSTRUCTION MACHINERY S.p.A.  
Printed in Italy - LEADER Firenze - Cod. 73301 452GB - Printed 02/08

Printed on recycled paper  
CoC-FSC 000010 CQ Mixed sources



ELEMENTAL  
CHLORINE  
FREE  
GUARANTEED

FIAT  
GROUP



BUILT AROUND YOU

[www.newholland.com](http://www.newholland.com)